

HARDI NAVIGATOR

Maintenance and Service Manual

67021404 - AU - 03/03

HARDI NAVIGATOR

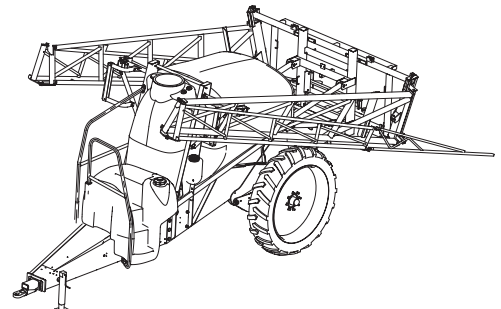
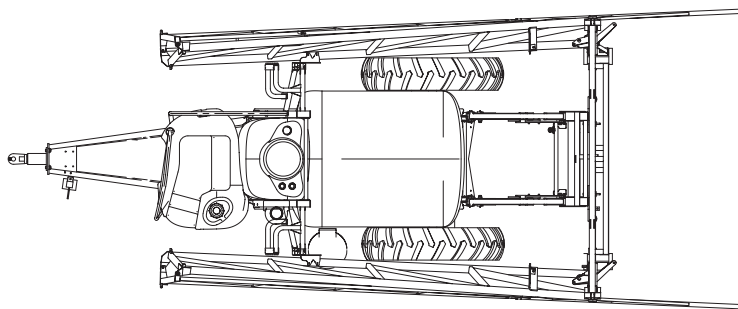
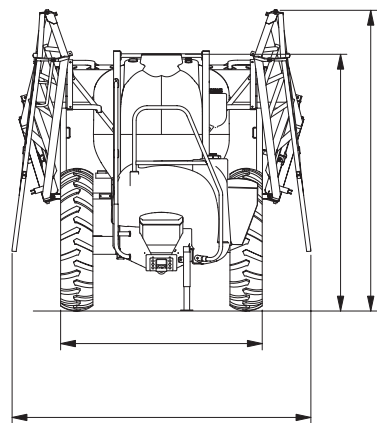
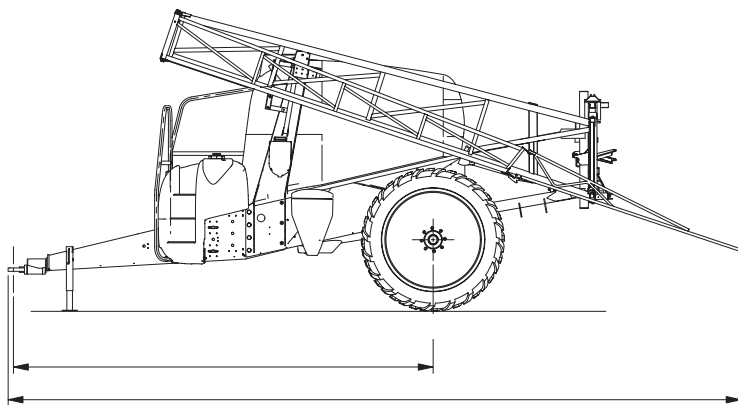

Note: Weights and dimensions vary significantly with different combinations of chassis, tank size, boom, axles, suspension, wheel sizes and accessories. For further information, contact your Hardi dealer.

HARDI NAVIGATOR Maintenance and Service Manual

Part number 67021404

MARCH 2003 Edition

Published by HARDI AUSTRALIA Pty Ltd
Adelaide, South Australia

Copyright © 2002 HARDI AUSTRALIA Pty Ltd
All rights reserved

Writing and layout by HARDI AUSTRALIA Pty Ltd
Printed in Australia



www.hardi.com.au

HARDI AUSTRALIA Pty Ltd assumes no responsibility for any errors, inaccuracies or possible omissions in this publication.

Illustrations, technical information and data are to the best knowledge of Hardi Australia Pty Ltd, correct at the time of printing.

HARDI AUSTRALIA Pty Ltd reserves the right to make changes in design, features, accessories, specifications and instructions at any time and without notice.

HARDI AUSTRALIA Pty Ltd is without any obligation in relation to products purchased before or after such changes.

All operators of the equipment dealt with by this publication must read this entire publication prior to operating any of the equipment. The safety section must be thoroughly read and understood.

Failure to do so may result in injury or death.

After changing chemicals or crops it is essential that the entire spraying system be flushed and thoroughly decontaminated in accordance with the chemical manufacturer's instructions (refer to the chemical label). This includes disconnecting hoses from the self cleaning filter and pressure relief valve and cleaning any residue and sediment found in the hoses, valve and filter.

Failure to do so may lead to potential crop damage.



WARNING!

Operating large agricultural vehicles near powerlines, even without actually touching them, can have serious consequences!

It is your responsibility to ensure that minimum safe clearances are strictly observed.

In particular when using spraying equipment it is necessary to be aware of the presence of powerlines when transporting the unit, spraying your crop, raising / tilting / lowering the boom, and when the operator is working above the vehicle.

Keep in mind that during hot weather there is potential for sagging of the lines, which will affect clearance distance.

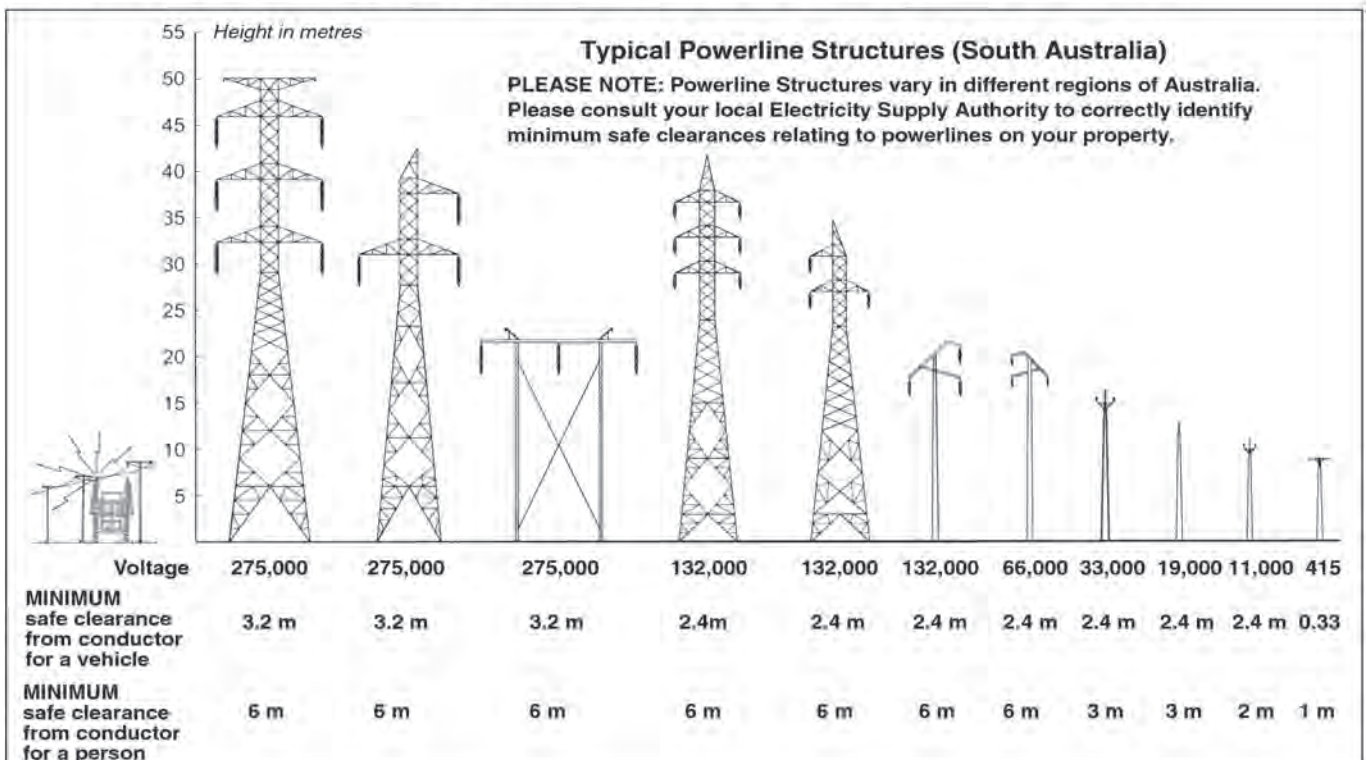

Contents

MAINTENANCE AND SERVICE MANUAL

Introduction.....4
 Sprayer Use / Layout / ID Plates.....4
Important Safety Guidelines.....5
Before operating sprayer.....5
 Roadworthiness.....5
 Disconnecting Sprayer.....5
 Transmission shaft installation.....6
 Wheel track.....6
 Tyres.....7
 Connecting hydraulics.....7
 Connecting electric controls.....8
 EVC 3 / EVC 4 Operating Unit.....8
 Control boxes and Power Supply.....8
 Controls Setup.....8
 Pressure Equalisation Setup.....8
 Subsequent Adjustments.....8
Emergency operation - Power Failure..... 8
Maintenance.....9
 Cleaning Guidelines.....9
 Lubrication.....10
 Pump.....10
 Transmission shaft.....10
 Support leg.....10
 Wheel bearings.....10
 Hitch.....10
 Service and maintenance schedules.....11
 Occasional maintenance.....13
 Pumps.....13
 EVC operating unit14
 EVC Operating Unit Valve Cone.....14
 Transmission shaft.....15
 Shock absorbers.....16
 Level indicator.....16
 Drain valve seal.....16
 Hoses and fittings.....17
 Tyres.....17
Storage.....18
 Preparation before off season storage.....18
 Preparation after off season storage.....19
Troubleshooting.....19
 Fluid System.....20
 EVC.....21
 Foam Marker.....21
Specifications.....22
 Torque settings.....22
 Tyre pressures.....22
 Temperature / Pressure / Flow.....22
 Dimensions.....22
 Pump capacity.....22
 Materials and recycling.....22
 Filters.....22
Function diagrams.....23
Replacement Parts.....24
 Parts Identification Contents.....24
 Parts Identification Drawings.....25-53
HARDI CONTACTS.....54
EMERGENCY CONTACTS.....54

OPERATORS MANUAL

Introduction.....4
 Sprayer Use / Layout / ID Plates.....4
Important Safety Guidelines.....4
Description.....5
Sprayer Setup.....6
 Connection.....6
 Support leg / Fold-down access step.....6
 Transmission shaft installation.....6
 Wheel track.....7
 Tyres.....8
 Connecting hydraulics.....8
 Connecting electric controls.....8
 Emergency operation - Power Failure.....9
Setup, Operation and Adjustment.....9
 EVC Operating Unit.....9
 Remote pressure gauge.....10
 Filters.....10
 Self cleaning filter.....10
 HARDI Foam Markers.....11
 Flush Tank and Flush Nozzles.....11
 Boom.....11
 Emergency operation - Power Failure.....11
Before operating sprayer.....12
 Roadworthiness.....12
 Disconnecting sprayer.....12
 Powerline Warning.....12
Function diagram.....13
OPERATION.....14
Filling Tanks with Water.....14
Adding Chemicals.....17
Spraying Operation.....20
 Interrupted Spraying and Standby Mode.....20
After spraying is completed.....21
 Disposal of unused and residual spray solution.....21
Draining Tanks.....21
Cleaning and Decontamination.....22
 Cleaning Procedure.....23
 Decontamination.....24
 Final Rinse.....24
Storage.....25
Specifications.....26
Notes.....27



Introduction

Congratulations on purchasing a HARDI NAVIGATOR sprayer. The reliability and efficiency of this sprayer depends upon your care.

The first step is to take the time to carefully read the HARDI NAVIGATOR Operators Manual, which includes information about Sprayer Setup and Adjustments, and Operation, Cleaning and Decontamination.

This HARDI NAVIGATOR Maintenance and Service Manual covers HARDI NAVIGATOR with PARALIFT-mounted FALCON or EAGLE boom.

The Operator's Manual for your boom is supplied with your NAVIGATOR sprayer documentation.

Thankyou for choosing HARDI and welcome to the increasing family of HARDI spraying equipment owners.

Sprayer Layout

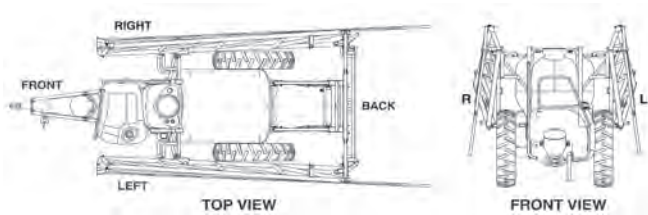

Sprayer Use

The HARDI NAVIGATOR sprayer is for the application of plant protection and liquid fertiliser chemicals. The sprayer must only be used for this purpose. It is not allowable to use the sprayer for other purposes. If no local law demands that the operator must be certified to use spray equipment, it is strongly recommended operators be trained in the safe handling of plant protection chemicals and plant protection, to avoid unnecessary risk for persons and the environment.

Identification plates

An identification plate is fitted on the frame and indicates: Producer Name, Model, Serial Number, Date and Dealer Name / Code.

The boom frame, centre frame and inner/outer sections also have identification plates.

Please record applicable details below:

Producer Name:

Model:

Serial Number:

Date:

Dealer Name / Code:



CAUTION! It is sometimes necessary to leave spray liquid in the tank for short periods (eg. overnight, during breakdowns, or until the weather becomes suitable for spraying again).





















Unauthorised persons and animals must not have access to the sprayer under these circumstances.



Important Safety Guidelines

This is the safety alert symbol:  When you see the symbol in this manual or on any spraying equipment, be alert! It means **WARNING! your safety is involved.**

Note the following recommended precautions and safe operating practices:

-  Read and understand this operators manual before using the equipment. Also ensure all other operators of this equipment read and understand this manual.
-  Always read chemical labels prior to use and follow the instructions they contain. Chemical labels are registered by the National Registration Authority. However each state governs the purpose for which a chemical may be used and this may vary from state to state.
-  Local law may demand that the operator be certified to use spraying equipment. Adhere to the law.
-  Pressure test with clean water prior to using chemicals.
-  Wear protective clothing.
-  Rinse and wash equipment after use and before servicing.
-  Depressurise equipment after use and before servicing.
-  Never service or repair the equipment whilst it is operating.
-  Disconnect electrical power before servicing.
-  Always replace all safety devices or shields immediately after servicing.
-  Disconnect power leads and electronic equipment before welding any part of the sprayer, boom or attached equipment. Remove all inflammable or explosive material from the area.
-  Do not eat, drink or smoke whilst spraying or working with contaminated equipment.
-  Wash and change clothes after spraying.
-  Wash tools if they have become contaminated.
-  In case of poisoning, immediately seek medical advice. Remember to identify chemicals used.
-  Keep children, animals and unauthorised people away from the equipment .
-  Never attempt to enter the sprayer tank.
-  Do not go under any part of the equipment unless it is securely supported. The boom is secure when placed in the transport brackets.
-  Do not use the sprayer step unless the sprayer is connected to the tractor or the sprayer is correctly placed on a hard, flat surface.
-  If any portion of this manual remains unclear after reading it, contact your HARDI dealer for further explanation before use or service of the equipment.
-  Do not affix or weld any additional item to the sprayer, as this may affect the structural integrity of your sprayer.

Before operating sprayer

Although the sprayer has had a strong and protective surface treatment applied to steel parts, bolts, etc. in the factories, it is recommended to apply a thin layer of anti-corrosion oil to all metal parts, hoses and tyres.

Suggested products for protecting your equipment are SHELL ENSIS or one of the CASTROL RUSTILLO range, eg DW9011M1.

There are many factors that affect the selection of protective oils, such as temperature and humidity, and exposure to UV, salt and chemicals. Your local distributor of oil products will be able to advise on the best specific formula for your local conditions.

If this is done before the sprayer is put into operation for the first time, it will always be easy to clean the sprayer, avoid chemicals discolouring the protective coating, and keep the coatings shiny for many years.

This treatment should be carried out every time the protective film is washed off.

Roadworthiness

When driving on public roads and any other areas where traffic laws apply, please ensure that the required signs and lights are fitted and working.

-  **WARNING!** Maximum driving speed is the lesser of: 20 km/h less than the posted speed limit; and 30 km/h; and Tyre manufacturers recommended max speed / load.

NOTE! It is always recommended to only move the sprayer by road with an empty tank.

NOTE! Ensure towing vehicle is suited to the total load.

Hardi recommends fitting spacers to drawbar hitches to prevent undue movement / bounce, and a safety locking device to the drawbar pin.

A safety chain attachment point is provided.

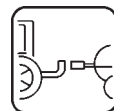

Disconnecting the sprayer

Always clean the sprayer inside and outside before disconnecting and parking. See Cleaning in your Operators Manual.

Before disconnecting the sprayer from the tractor, make sure the support leg is properly fitted.

-  **WARNING!** To prevent the sprayer from tipping over, do not disconnect the sprayer from the tractor with the boom unfolded.

Place stop wedges in front of and behind the wheels, and disconnect all hoses and cables from the tractor.

-  **WARNING!** If the sprayer is parked unattended, avoid unauthorised persons, children and animals having access to the sprayer.

Transmission shaft installation

NOTE! The shaft must always have a minimum overlap of $\frac{1}{3}$ of the length.

NOTE! Please fit the female part marked with a tractor symbol towards the tractor.

NOTE! To ensure long life of the transmission shaft try to avoid working angles greater than 25° .

Initial installation of the transmission shaft may require shortening of the shaft.

- 1 Attach the sprayer to the tractor and set the sprayer at a height allowing the shortest length of the transmission shaft with the tractor set at a turning angle.
- 2 Stop the engine and remove the ignition key.
- 3 If the transmission shaft must be shortened, pull the shaft apart. Fit the separated shaft parts to the tractor and sprayer pump and measure how much it is necessary to shorten the shaft. Mark the protection guards.

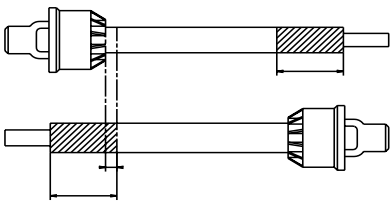

Fig 1

NOTE! The shaft must always have a minimum overlap of $\frac{1}{3}$ of the length.

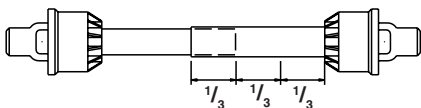

Fig 2

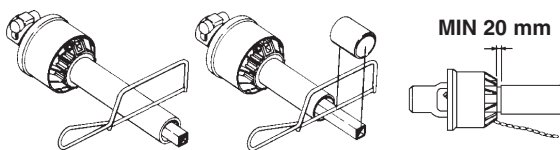

Fig 3

- 4 Shorten the two separated parts equally. Use a saw and file the profiles afterwards to remove burrs.
- 5 Grease profiles. Re-assemble male and female parts.
- 6 Grease the tractor and sprayer pump PTO shafts.
- 7 Fit the transmission shaft to the tractor and sprayer pump PTO shafts:
Push the yoke pin and slide the yoke onto the PTO shaft. Make sure that the lock engages by pushing

and pulling forwards and backwards or if applicable by tightening the allen key. Fit the chains to prevent the protection guards from rotating with the shaft.

NOTE! Please fit the female part marked with a tractor symbol towards the tractor.

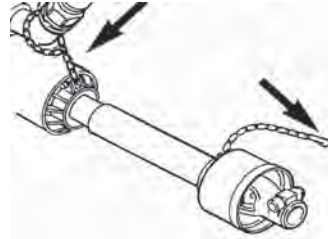

Fig 4

NOTE! To ensure long life of the transmission shaft try to avoid working angles greater than 25° .

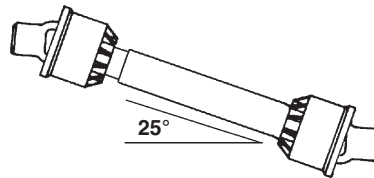

Fig 5

Wheel track

Where an adjustable axle is fitted, the wheel track can be altered infinitely from 1500 mm to 3000 mm by extending or retracting the wheel axle, depending on wheel and suspension options.

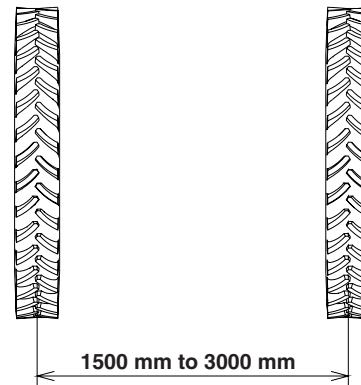

Fig 6



WARNING! It is not permitted to fit dual wheels.

CAUTION! Stability of the sprayer at high speed can be reduced with narrow wheel tracks.

Wheel track is altered using the procedure on the following page:

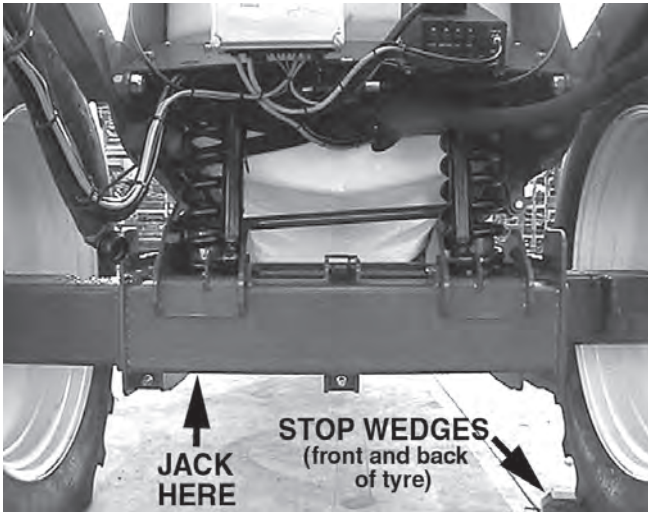

Fig 7

- 1 Measure the correct wheel track (Centre of right hand tyre to centre of left hand tyre). Extend or retract each side equally to achieve the desired alteration.
- 2 Attach sprayer to the tractor and engage tractor parking brake.
- 3 Place stop wedges in front of and behind the right hand wheel. Using suitable heavy duty equipment, jack up the left hand wheel. Ensure secure support for the sprayer body.
- 4 To release axle wedge for the left hand wheel axle and extend or retract the axle:
Turn Nut C (Fig 8) anti-clockwise to allow approx. 30mm clearance. With an open-ended spanner, turn Nut D (Fig 8) against anchor plate until hold on axle is released. Shift axle to measured position.

- 5 To tighten axle wedge and secure axle at required width:
Turn Nut D anti-clockwise to allow movement of stop wedge. Turn Nut C clockwise against anchor plate to draw stop wedge up against the axle and hold it in position. Tighten to torque of 280 Nm, then lock by re-tightening Nut D.
 - 6 If the wheels are reversed and exchanged, remember to tighten the wheel nuts to the specified torque - rim plate to hub 490 Nm.
 - 7 Repeat the procedure on the right hand wheel.
 - 8 Check the distance from the centre of the tyre to the centre of the tank, to ensure the distance is equal from left to right.
 - 9 Re-tighten the clamp bolts and wheel nuts to the specified torque after 8 hours of work.
- IMPORTANT!** Always place a jack under axle and lift the wheel to remove the load from the clamps before tightening the clamp bolts.

Tyres

Equal pressure in both tyres is essential. Pressure should be kept as low as practical, i.e. baggy when the tank is full. For recommended pressures see Page 22.

NOTE! Sprayers fitted with controllers must always maintain the same tyre pressure as when calibrated.



WARNING! Never inflate tyres above the specified pressures. Over inflated tyres can explode and cause severe personal injuries.

Connecting hydraulics

Please refer to the Boom Operator's Manual supplied with your sprayer documentation regarding connecting hydraulics, boom operation, adjustment and maintenance.

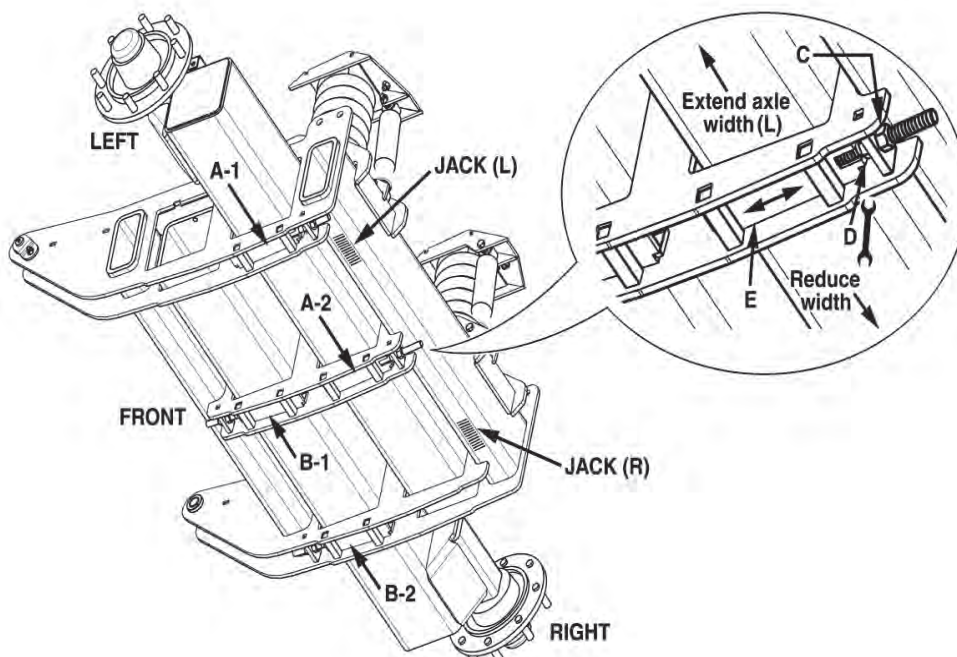

Fig 8

Control boxes and power supply

Power requirement is 12V DC. Note Polarity!

For EVC: Brown pos. (+), Blue neg. (-).

The control boxes for EVC-operating unit and D.A.H. are fitted in the tractor cabin at a convenient place. Tapping screws can be used for mounting.

Connecting electric controls

Control boxes must be fitted in the tractor cabin at a convenient place. 12 V power sockets are required.

The wires must have a cross-sectional area of at least 4.0 mm² to ensure sufficient power supply. The boxes must be fused according to the following table.

Control Box	Polarity / Wire colour		Fuse (Amp)
	(+)	(-)	
EC operating unit	Brown	Blue	8
Foam marker	White	Black	16
Distribution valves	Brown	Blue	8

NOTE! Please refer to the Boom Operator's Manual supplied with your sprayer documentation regarding connecting hydraulics, boom operation, adjustment and maintenance.

Controls Setup Procedure

Before spraying, the EVC operating unit is adjusted using clean water (ie without chemicals).

- 1 Choose the correct nozzle for the spray job. Make sure that all nozzles are the same type and capacity. Please see your dealer or the Hardi Spray Technique book for Nozzle selection guidance.
- 2 Switch on the EVC using the Controller.
- 3 Activate all distribution valves to the open position.
- 4 Decrease the pressure until the pressure control valve handle (A Fig 9) stops rotating (min. pressure).
- 5 Put the tractor in neutral and adjust the PTO revolutions to the intended travelling speed. The PTO must be kept between 300- 600 rpm (540 pump) or 650- 1100 rpm (1000 pump).
- 6 Increase the pressure until the required pressure is shown on the pressure gauge.

Pressure equalisation Setup Procedure

- 1 Close the first section of the distribution valves (A Fig 10).
- 2 Turn the first section adjusting screw (B Fig 10) until the pressure gauge shows the same pressure again.
- 3 Leaving the 1st section off, repeat procedure to adjust with the next section off. Continue until all sections are off - the gauge should still read the same pressure.

Subsequent Adjustments

NOTE! Hereafter adjustment of pressure equalisation will only be needed when you change to nozzles with other capacities or the nozzle output increases as the nozzles wear.

Please see your dealer or the Hardi Spray Technique book for Nozzle selection guidance.

Emergency operation

Boom

Refer to the *Troubleshooting* section in the *FALCON or EAGLE PARALIFT Boom Operator's Manual* supplied with your sprayer documentation. In case of power failure on units fitted with solenoid valves, the boom can be operated manually by pressing the the centre of individual buttons on the solenoid valves. This is done by locking the by-pass valve.

EVC Operating Unit

Refer to the *Troubleshooting* section on Page 21.

In case of power failure, the problem may be due to a blown fuse. Refer to the Controller Manual supplied with your sprayer.

It is possible to operate all functions of the operating unit manually. First disconnect the Controller, then manually turn the emergency control knobs.

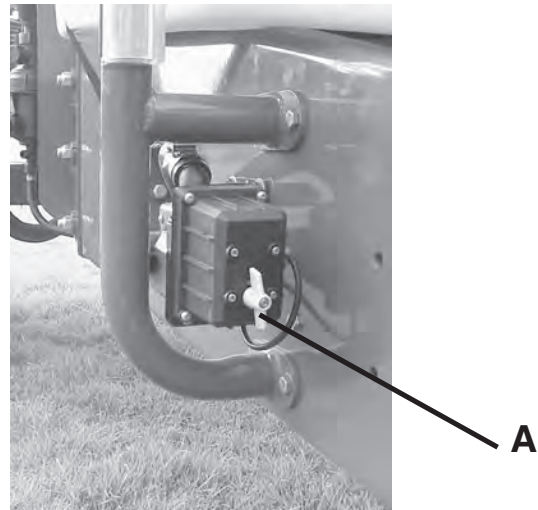

Fig 9

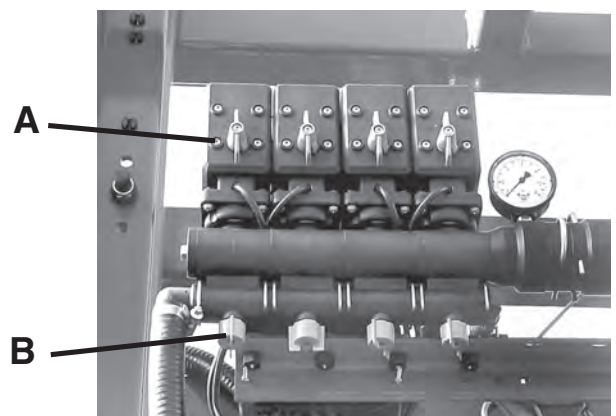

Fig 10

CLEANING and DECONTAMINATION

In order to derive full benefit from the sprayer for many years, the following maintenance program should be followed.

IMPORTANT! Always read carefully through the individual paragraphs regarding maintenance jobs before starting the job. If any portion remains unclear or requires facilities which are not available, then for safety reasons please leave the job to your HARDI dealer's workshop.

NOTE! For specific maintenance of the boom, please refer to your *FALCON or EAGLE PARALIFT BOOM Operator's Manual* supplied with your sprayer documentation.

To effectively maintain the sprayer you must:

- 1 Perform **Cleaning** of the entire sprayer after spraying is completed - Refer to *Operators Manual*. Specific cleaning of filters also forms part of the service and maintenance intervals - Refer *Service and maintenance charts* (Page 12).
- 2 Perform **Lubrication** according to the lubrication interval reached - Refer to *Lubrication* (Page 10).
- 3 Perform **Service and maintenance** jobs according to the service and maintenance interval reached - Refer to *Service and maintenance charts* (Page 12).
- 4 Perform **Occasional maintenance** jobs as needed following inspections - Refer to *Occasional maintenance* (Page 14).
- 5 Immediately fit **Replacement parts** for parts that are worn or broken - Refer to *Replacement Parts* (P 24).

REMEMBER!

**Clean sprayers are safe sprayers.
Clean sprayers are ready for use.
Clean and well protected sprayers will not be damaged by chemicals.**

GENERAL CLEANING GUIDELINES

IMPORTANT! The entire fluid system, including main tank, flush tank, chemical induction system and all hoses, valves, spray lines and nozzles, must undergo decontamination during the cleaning procedure to ensure the sprayer is free of chemical residue before storage or using a different chemical.

Read detergent and deactivating agent labels. Read the whole chemical label. Take note of particular instructions regarding recommended protective clothing, deactivating agents, etc.

If cleaning procedures are given, follow them closely.

Comply with local legislation regarding disposal of chemical washings, mandatory decontamination methods, etc. Contact the appropriate body, e.g. Dept of Ag.

Chemical washings can usually be sprayed out on a soakway or an area of ground that is not used for cropping.

Seepage or runoff of residue into streams, water courses, ditches, wells, springs, etc., must be avoided. Washings from the cleaning area must not enter sewers.

NOTE! Well-calibrated sprayers ensure minimal spray solution left over after each spraying job.

Clean the sprayer immediately after use leaving the sprayer safe and ready for the next chemical application. This also prolongs the life of the components.

If a spraying or cleaning product is corrosive, it is recommended to coat all metal parts of the sprayer, before and after use with a suitable rust inhibitor.

NOTE! If a sprayer is cleaned with a high pressure cleaner (or fertiliser has been used), lubrication of the entire sprayer is recommended - including the boom. (Refer to the boom operator's manual supplied with your sprayer documentation, regarding lubrication of boom).



AGRICULTURAL CHEMICAL RESIDUES CAN DESTROY YOUR NEXT CROP!



Lubrication

Store lubricants in a clean dry and cool place - preferably at constant temperature - to avoid contamination from dirt and condensed water. Keep oil filling jugs, hoppers and grease guns clean, and clean the lubricating points thoroughly before lubricating.

Avoid long periods of skin contact with oil products.

Recommended lubrication intervals and lubricants are as follows:

LUBRICATING POINT	LUBRICANT
Ball bearings A	Universal Lithium grease NLGI #2 SHELL RETINAX A CASTROL LM GREASE
Slide bearings B	Lithium Grease with Molybdenumdisulphide and Graphite SHELL SAS 4000 CASTROL MOLYMAX
Oil lube points C	Engine Oil

— Grease (A or B)
 — Lubrication Interval (Hours)

— Oil (C)
 — Lubrication Interval (Hours)

Pump

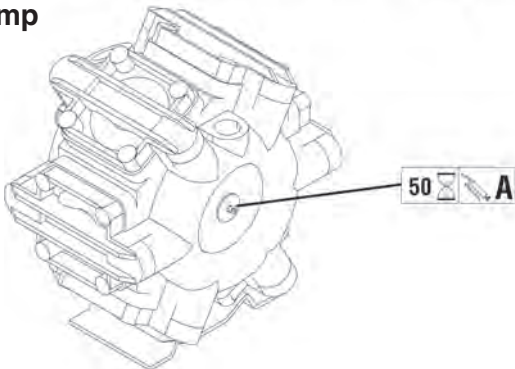

Fig 11

NOTE! Ace Pumps have factory lubricated bearings and require no further lubrication.

Transmission shaft

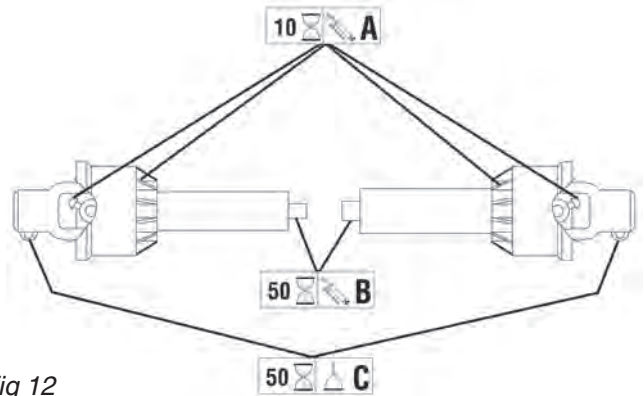

Fig 12

Support leg

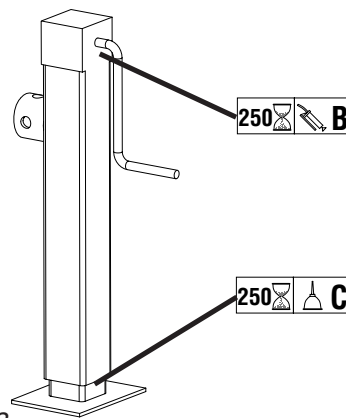

Fig 13

Wheel bearings

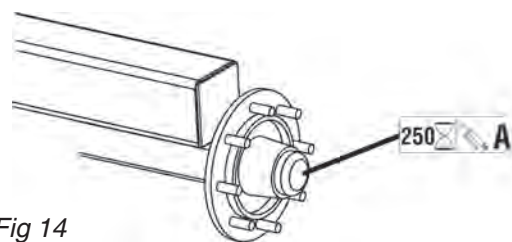

Fig 14

Hitch

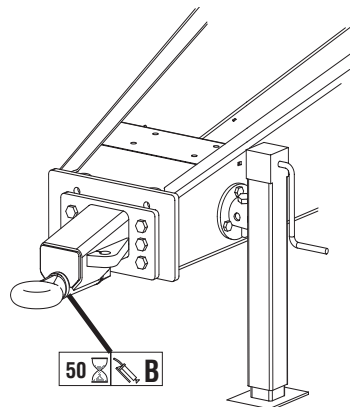

Fig 15

Service and maintenance schedules

Recommended Service and Maintenance intervals for HARDI NAVIGATOR.

10 Hours or Daily (Whichever occurs first)

- 1 Suction filter: Clean.
- 2 Self cleaning filter: Check and clean gauze if necessary.
- 3 In-Line filters (If fitted): Clean.
- 4 Nozzle filters: Clean.
- 5 Spraying circuit: Check for leaks.
- 6 Transmission Shaft: Grease as in diagram (left).

50 Hours or Weekly (Whichever occurs first)

Do all previous +

- 7 Wheel studs and nuts: Re-tighten.
- 8 Drawbar bolts: Re-tighten.
- 9 Tyres: Check pressure.
- 10 Transmission shaft: Check condition of protection guards. Lubricate as in diagram (left).
- 11 Pump: Grease as in diagram (left).
- 12 Hitch: Grease as in diagram (below left).

250 Hours or Monthly (Whichever occurs first)

Do all previous +

- 13 Wheel bearings: Check, grease (see left) and adjust if necessary.
- 14 Hoses and tubes: Check for possible damage and proper attachment.
- 15 Support Leg: Grease as in diagram (left).

1000 Hours or Yearly (Whichever occurs first)

Do all previous +

- 16 Wheel bearings: Dismantle, check, grease and adjust.
- 17 Transmission shaft: Renew protection guard bearings.

10 Hours / Daily Service

1 Suction filter

To service the suction filter:

- 1 Pull the steel clip (**A** Fig 16) out.
- 2 Lift suction hose fitting (**B** Fig 16) from the housing.
- 3 The filter guide and filter (**C** Fig 16) can now be removed.

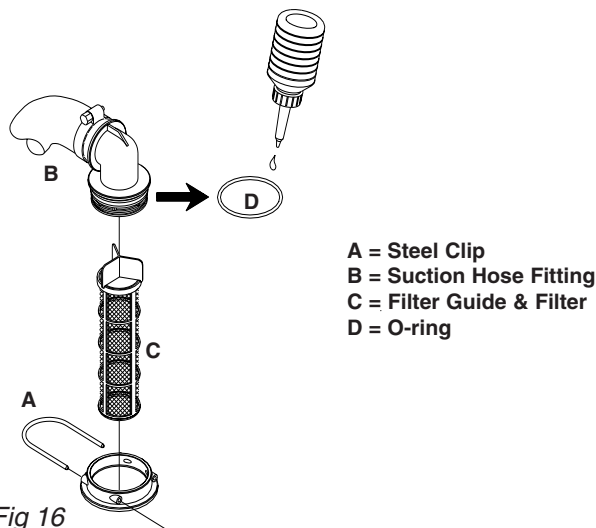

Fig 16

To reassemble:

- 1 Press the guide onto the filter end.
- 2 Place filter into the housing with the guide facing up.
- 3 Ensure the O-ring (**D** Fig 16) on the hose fitting is in good condition and lubricated.
- 4 Refit suction hose (**B** Fig 16) and steel clip (**A** Fig 16).

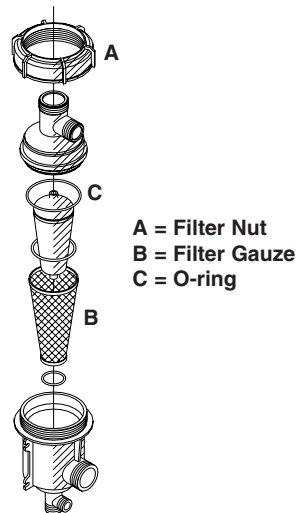

Fig 17

2 Self cleaning filter

Read Self cleaning filter section of Operators Manual.

- 1 Unscrew the filter nut (**A** Fig 17) and open the filter.
- 2 Check the filter gauze (**B** Fig 17). Clean and check there are no residues on any part of the filter hoses.
For Replacement Parts, see Drg 6, Page 30.
- 3 Lubricate the O-ring (**C** Fig 17).
- 4 Reassemble the filter.

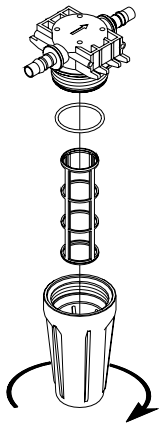

Fig 18

3 In-Line filters (If fitted)

If the sprayer is equipped with In-line filters, unscrew the filter bowl to inspect and clean a filter. Lubricate O-rings. Alternative filters are available. Refer to *Filters*, (Page 16) and *Filters*, (Page 38).



Fig 19

4 Nozzle filters

- 1 Remove the nozzle.
- 2 Clean the nozzle, filter and filter gasket.
- 3 Check parts for deterioration. Replace if necessary.
- 4 Refit filter and nozzle. Repeat for each nozzle.

50 Hours / Weekly Service

6 Wheel studs and nuts

Tighten wheel studs and nuts as follows with the following torque wrench settings:

Wheel hub to rim plate: 490 Nm (362 lbf-ft)

Rim plate to rim: 310 Nm (230 lbf-ft)

Tightening sequence:

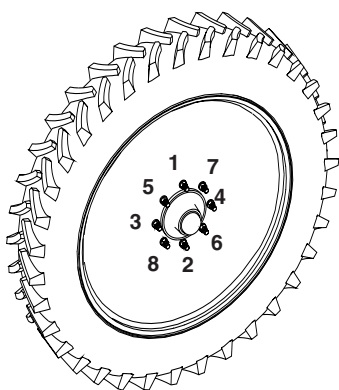

Fig 20

7 Draw bar bolts

The draw bar bolts must be tightened as follows:

- 1 Jack up chassis so there is no load on the drawbar.
- 2 Tighten chassis bolts (A Fig 21) - 370 Nm (270 lbf-ft).
- 3 Tighten hitch bolts (B Fig 21) - 190 Nm (140 lbf-ft).

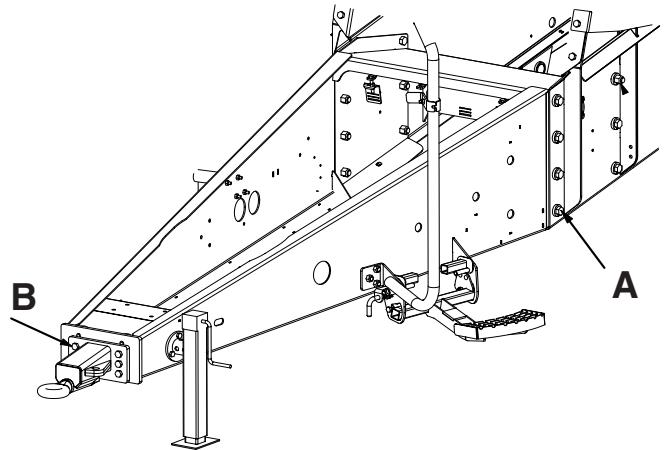

Fig 21

8 Tyres

Check the tyre pressures against the table below, and Load Limit table on page 22.

TYRE	PRESSURE (kPa)	
	Road (Max)	Work (Recommended)
12.4 x 46	240	145-155
18.4 x 38	240	145-155
18.4 x 30	200	145
23.1 x 30	200	145

WARNING! Over-inflated tyres may explode and cause severe damage or personal injuries.

9 Transmission shaft

Check function and condition of the transmission shaft's protection guards. Replace any damaged parts immediately.

250 Hours / Monthly Service

10 Wheel bearings

Check for play in the wheel bearings:

- 1 Place stop wedges in front of and behind the left hand wheel and jack up the right hand wheel.
- 2 Rock the right hand wheel to discover possible play in the bearings.
- 3 If there is any play, support the wheel axle to prevent the trailer from falling down from the jack.
- 4 Remove the hub cap (A Fig 44) and cotter pin (B Fig 44). Turn the wheel and tighten castelated nut (C Fig 44) until slight resistance in wheel rotation is felt.
- 5 Loosen castelated nut until first notch - horizontal or vertical - is aligned with cotter pin hole in the shaft.
- 6 Fit a new cotter pin and bend it.
- 7 Fill the hub cap with fresh grease and press it on to the hub again.
- 8 Repeat the procedure on the left hand wheel.

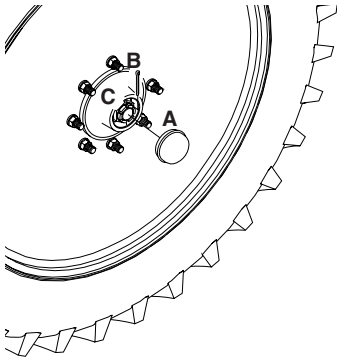

Fig 44

11 Hoses and tubes

Check all hoses and tubes for possible damage and proper attachment. Renew damaged hoses or tubes.

1000 Hours / Yearly Service

12 Wheel bearings

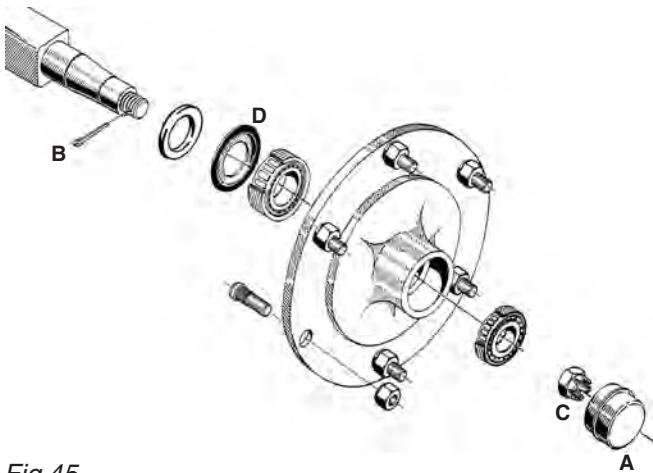

Fig 45

Check the condition of the bearings the following way:

- 1 Place stop wedges in front of and behind the left hand wheel and jack up the right hand wheel.
- 2 Support the trailer with axle stands.
- 3 Remove the wheel.
- 4 Remove the hub cap (A Fig 45), cotter pin (B Fig 45) and castle nut (C Fig 45).
- 5 Pull off wheel hub. Use a wheel puller if necessary.
- 6 Check roller bearings for discoloration and wear - renew if worn or damaged.
- 7 Assemble the hub and bearings using a new sealing ring (D Fig 45).
- 8 Fill the hub and bearings with fresh grease before fitting to the shaft.
- 9 Fit castelated nut. Rotate hub and tighten the castelated nut until a slight rotation resistance is felt.
- 10 Loosen the castelated nut again until the first notch is aligned with the cotter pin hole in the shaft.

NOTE! The shaft has a vertical and a horizontal cotter pin hole. Use the one first aligned with the notch when loosening the castelated nut.

- 11 Fit a new cotter pin and bend it.
- 12 Fill the hub cap with fresh grease and carefully press it onto the hub.
- 13 Fit the wheel again and tighten the wheel nuts. (Refer *50 Hours / Weekly Service* (Page 27) for torque wrench setting. Tighten all bolts to half the specified torque first, then to the full specified torque.
- 14 Tighten again after 10 hours of work. Check the torque every day until it is stabilised.
- 15 If you do not feel totally confident changing wheel bearings, contact your HARDI dealer's workshop.

13 Transmission shaft

Change the protection tube nylon bearings as described in *Shield renewal* (Page 30).

Occasional maintenance

Maintenance and renewal intervals for the next points depend very much on conditions under which sprayer operates, and are therefore impossible to specify.

363 or 463 pump

NOTE! It is recommended that if one or more diaphragms and/or valves need replacing they all should be replaced

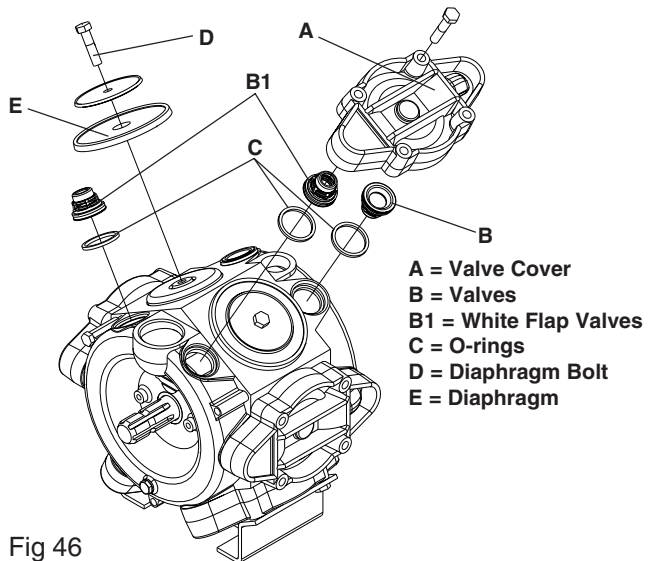

Fig 46

Changing valves

- 1 Remove the valve covers (A Fig 46). Before changing the valves (B Fig 46 & B1 Fig 46) note their orientation so they are replaced correctly.
- 2 The two white flap valves (B1 Fig 46) must be placed in the valve openings as shown. It is recommended to use new O-rings (C Fig 46) when changing or checking the valves.

Changing diaphragms

- 1 With the valve covers removed as explained above, remove the diaphragm bolts (D Fig 46).

- 2 The diaphragms (E Fig 46) may now be changed.
- 3 If fluids have reached the crankcase, re-grease the pump thoroughly. Ensure the drain hole at the bottom of the pump is clear.

NOTE! When tightening diaphragm cover it must be ensured that diaphragm is **in neutral or out**. If the diaphragm is in negative, the edge of the diaphragm is not seated correctly in the diaphragm cover. This will damage the diaphragm which will not seal correctly after being re-assembled.

Rotate the pump until the diaphragm is neutral or out.

- 4 Reassemble with torque settings as in *Torque* (P 23).

ACE pump

To Replace Pump Seal

- 1 Remove screws (A Fig 47), motor (B) and coupler (C).
- 2 Remove rear bearing snap ring (D), four screws (S) from mounting frame (E), and volute (F).
- 3 Remove lock nut (G) and washer (H) from shaft (I).
- 4 Carefully hold impeller vane (J) stationary, and press shaft out of impeller using one of the long hex screws.
- 5 Remove impeller, key (K) and rotating seal member (L). Press shaft (with bearings (M)) assembly out of frame.
- 6 Remove stationary seal member (N) and O-ring (O) from shaft groove.
- 7 Press shaft / bearing assembly back into frame, and re-install the rear internal bearing snap ring.
- 8 Clean old sealant from mounting frame seal bore.
- 9 Apply non-hardening gasket cement under stationary seal member flange, place over shaft and press into seal bore cavity. Use a length of 1 3/4" ID pipe as a tool to press seal flange down evenly on all sides.
- 10 Install rotating seal part over shaft and O-ring by hand, avoiding contact with the polished seal faces. The two polished faces should face each other.
- 11 Insert key in keyway and install impeller on shaft. Place lock washer and nut on shaft and tighten nut.
- 12 Replace volute O-ring (P), and volute. Secure with screws.
- 13 Position coupler in pump shaft slot. Fill cavity around coupler with grease.
- 14 Install motor by aligning motor tang and coupler slot. Rotate motor until nameplate faces up and secure with screws.

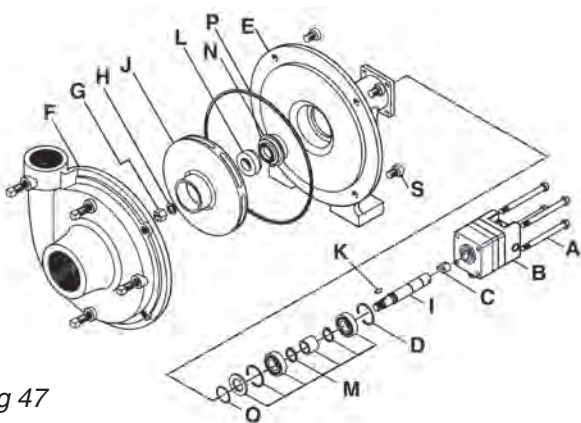

Fig 47

EVC Cone check / renewal - operating unit

If the main on/off valve does not seal properly (dripping nozzles when main on/off valve is closed), build up of sufficient pressure becomes difficult or pressure fluctuations occur, cone and cylinder may need replacing. Hardi Kit for this job is Part No 741293.

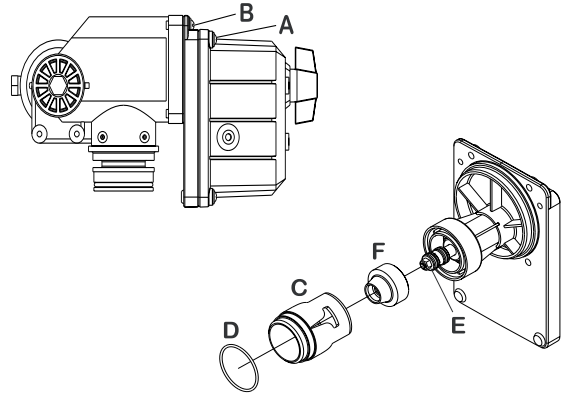

Fig 48

- 1 Remove 4 screws (A Fig 48) and remove housing.
- 2 Remove 4 screws (B).
- 3 Replace cylinder (C) and O-ring (D).
- 4 Loosen Nut (E). Remove and replace Cone (F).
- 5 Reassemble in reverse order.

EVC Cone check / renewal - distribution valve

Periodically check the distribution valves for proper sealing. Do this by running the sprayer with clean water and opening all distribution valves.

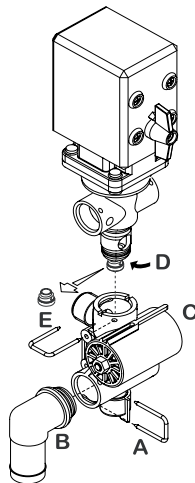

Fig 49

- 1 Cautiously remove the clip (A Fig 49), (**Note: Chemical spill risk!**) and pull out the hose (B). When the housing is drained, there should be no liquid flow through the pressure equalization device. If there is any leakage, valve cone (E) must be changed.
- 2 Remove clip (C). Lift motor housing off valve housing.
- 3 Unscrew screw (D) and replace valve cone (E).
- 4 Reassemble in opposite sequence.

Transmission shaft

Shield renewal

The replacement of defective shields is done as follows:

- 1 Push down on the universal cross cover and press in the tabs with a screwdriver. Maintain pressure until all three tabs are released.

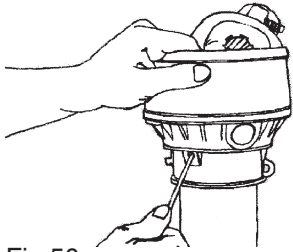

Fig 50

- 2 Remove the nylon bearing and pull off the protection

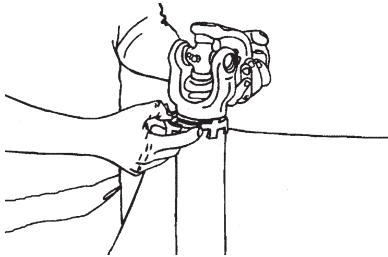

Fig 51

- 3 Grease the protection tube bearing groove on the inner yoke.

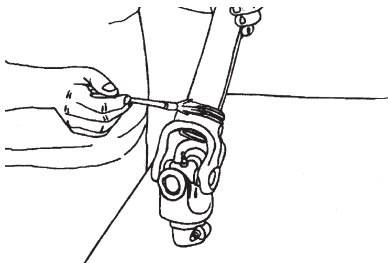

Fig 52

- 4 Slide on the shield tube and fit the bearings tabs into the slots.

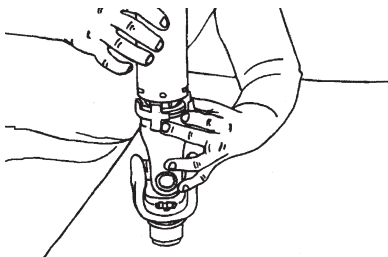

Fig 53

- 5 Slide the universal cross cover over the protection tube and align the grease nipple with the grease channel on the bearing. Press the universal cross cover onto the tabs until they lock.

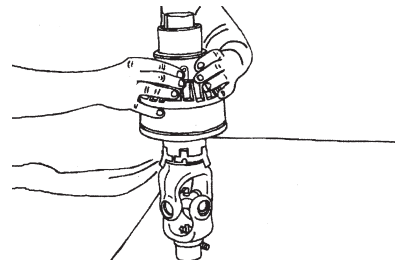

Fig 54

- 6 Check alignment and locking of the tabs by tapping the universal cross cover lightly.

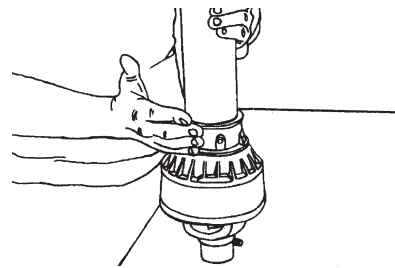

Fig 55

Constant velocity joint shielding renewal

- 1 Remove the screws holding the two halves of the shield together.

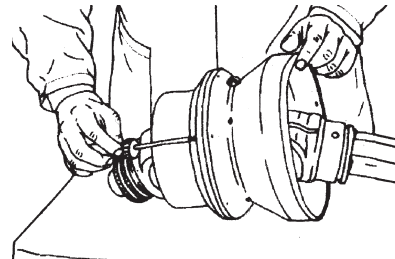

Fig 56

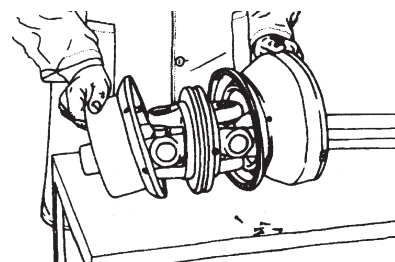

Fig 57

- 3 Lubricate the bearing surfaces on the central body of the joint. Align the two halves of the shield and secure with the screws.

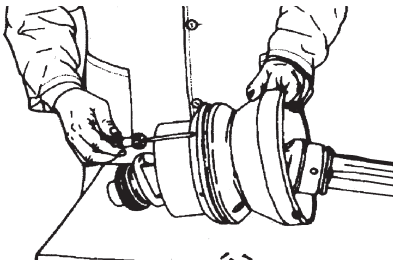

Fig 58

NOTE! Use only genuine spare parts to service the transmission shaft. For any other service or repair jobs on the transmission shaft contact your HARDI dealer.

Shock absorbers

If the shock absorbers loose their efficiency or start leaking oil, they should be replaced.

Level indicator

The level indicator should be checked regularly. When the tank is empty, the floater should rest on the stop pin at the bottom of the rod inside the tank, and the O-ring at the sight gauge indicator should be positioned at the top position line (A Fig 59).

If any deviation is found, pull out the plug (B Fig 59), loosen the screws (C Fig 59) and adjust the length of the cord.

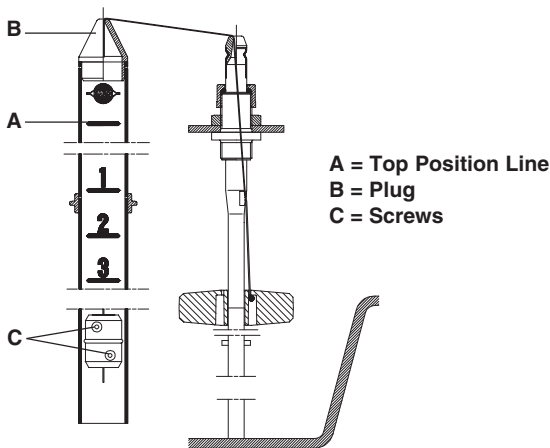

Fig 59

Cord renewal

If the cord on the level indicator has to be changed, the float guide pole must be removed:

- 1 Remove the tank drain valve (Refer *Drain valve seal*) and loosen the fitting holding the pole in position.
- 2 Pull the pole down through the drain valve hole until it is free in the top of the tank.
- 3 The pole can now be taken out of the tank through the filling hole.



DANGER! Do not attempt to enter the tank - the float pole can be removed from outside the tank!

Drain valve seal

If the main tank drain valve leaks, the seal and seat can be changed the following way:

NOTE! Do not enter the inside of the tank - the parts can be changed from underneath the tank.



WARNING! Use an eye/face protection mask when dismantling the tank drain valve.

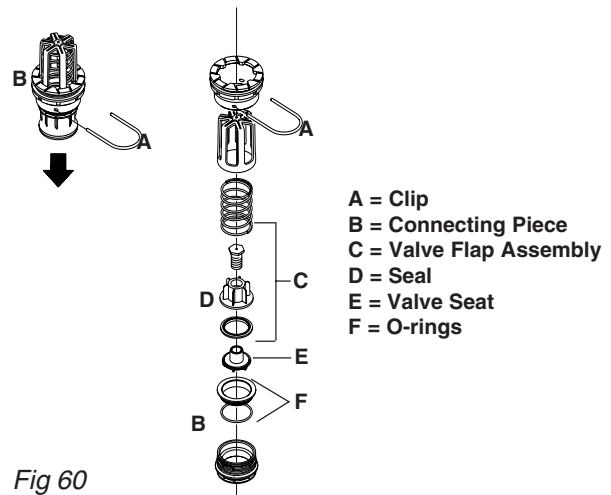

Fig 60

NOTE! Check the function of the valve with clean water before filling chemicals into the tank.

- 1 Make sure the tank is empty and clean.
- 2 The valve must be closed and the string loose.
- 3 Pull out the clip (A Fig 60) and pull down the connecting piece (B Fig 60). The entire valve assembly can now be pulled out.
- 4 Check the cord and valve flap assembly (C Fig 60) for wear, replace the seal (D Fig 60) and reassemble.
- 5 Assemble the valve assembly again using a new valve seat (E Fig 60). Lubricate the O-rings (F Fig 60) before assembly.
- 6 Fit the clip (A Fig 60) again.

Hoses and fittings

Poor seals are usually caused by:

- Missing O-rings or gaskets
- Damaged or incorrectly seated O-rings
- Dry or deformed O-rings or gaskets
- Foreign bodies

Therefore, in case of leaks:

Do not over-tighten. Disassemble, check condition and position of the O-ring or gasket, clean, lubricate and reassemble. The O-ring is lubricated **all the way round** before fitting on to the nozzle tube. Use non-mineral lubricant.

For **radial** connections, only hand tighten them.

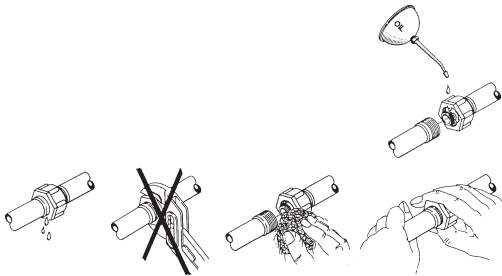

Fig 61

For **axial** connections, a little mechanical leverage may be used.

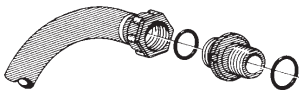

Fig 62

Tyres

Should it be necessary to replace tyres, follow the following rules when doing so. If uncertain about any aspect, have a specialist do the job:

- Always clean and inspect the rim before mounting.
- Always check that the rim diameter corresponds exactly to the rim diameter moulded on the tyre.
- When fitting new tubed tyres always fit new tubes. Always use tubes of recommended size and of good condition.
- Inspect inside the tyre for dirt or foreign bodies and remove them if installing a tube.
- Do not use tubes in tubeless tyres.
- Tyres with irreparable damages must never be used.
- Always inspect inside the tyre for cuts, penetrating objects or other damage. Damages must be repaired before installing a tube.
- Before mounting always lubricate both tyre beads and rim flange with an approved lubricating agent or equivalent anti-corrosion lubricant. Never use petroleum based greases and oils because they may result in damage to the tyre. Using the appropriate lubricant the tyre will never slip on the rim.
- Always use specialised tools as recommended by the tyre supplier for mounting the tyres.
- Make sure that the tyre is centred and the beads are perfectly seated on the rim. Otherwise danger of bead wire tear can occur.
- Inflate the tyre to 100 - 130 kPa (14.5 - 19 psi) then check whether both beads are seated perfectly on the rim. If any of the beads do not seat correctly, deflate the assembly & re-centre the beads before starting inflation of the tyre. If the beads are seated correctly on the rim, inflate the tyre to a maximum of 250 kPa (36 psi) until they seat perfectly on the rim.
- Never exceed the maximum mounting pressure moulded on the tyre.
- After mounting tyres adjust inflation pressure to operation pressure recommended by the tyre manufacturer. *Tyre pressures and Load limits*(Page 22) can be used as a guide.



WARNING! Non observance of mounting instructions will result in the bad seating of the tyre on the rim and could cause the tyre to burst, leading to serious injury or death.

CAUTION! Never mount or use damaged tyres or rims!

CAUTION! Use of a damaged, ruptured, distorted, welded or brazed rim is not acceptable and may be the cause of serious injury.



Storage

When the spraying season is over, you should devote some extra time to the sprayer before it is stored.

If chemical residues are left in the sprayer for long periods, it can reduce the life of individual components.

Preparation before off season storage

To preserve the sprayer and protect the components, carry out the following off season storage program.

- 1 Clean the sprayer completely - inside and outside as described in *Cleaning* (Page 24). Make sure that all valves, hoses and auxiliary equipment have been cleaned with detergent and flushed with clean water, so no chemical residues are left in the sprayer.
- 2 Renew any damaged seals and repair any leaks.
- 3 Empty the sprayer completely and let the pump work for a few minutes. Operate all valves and handles to drain as much water off the spraying circuit as possible. Let the pump run until air is coming out of all nozzles. Remember to drain the rinsing tank. Ensure the foam marker is rinsed and drained.
- 4 If the sprayer is not stored in a frost free place, pour in a mixture of Ethylene Glycol based anti-freeze and water at the ratio for the desired temperature protection. Volume of mixture should be about 1% of tank volume. Run the sprayer and circulate the anti-freeze in the pump, controls and boom lines.
- 5 Lubricate all lubricating points regardless of intervals stated.
- 6 When the sprayer is dry remove rust from possible scratches or damages in the powdercoat and touch up with paint.
- 7 Remove the Glycerine filled gauges and store them in a frost free vertical position.
- 8 Apply a thin layer of anti-corrosion oil to all metal parts, hoses and tyres. Suggested products for protecting your equipment are HENKEL, SHELL ENSIS or one of the CASTROL RUSTILLO range, eg DW9011M1. Contact your Hardi Dealer for updated recommendations.

There are many factors that affect the selection of protective oils, such as temperature and humidity, and exposure to UV, salt and chemicals. Your local distributor of oil products will be able to advise on the best specific formula for your local conditions.
- 9 Fold the boom to transport position and relieve pressure from all hydraulic functions.
- 10 All electric plugs and sockets are to be stored in a dry plastic bag to protect them against damp, dirt and corrosion.

- 11 Remove any control boxes and display (if fitted) from the tractor and store them inside where it is dry and clean.
- 12 Wipe the hydraulic snap-couplers clean and fit the dust caps.
- 13 Apply grease onto all hydraulic ram piston rods that are not fully retracted in the barrel, to protect against corrosion.
- 14 Chock up the wheels, to prevent moisture damage and deformation of the tyres. Tyre blacking can be applied to the tyre walls to preserve the rubber.
- 15 To protect against dust the sprayer can be covered by a tarpaulin. Ensure ventilation to prevent condensation.

Preparation after off season storage

After a storage period the sprayer should be prepared for the next season the following way:

- 1 Remove the cover.
- 2 Remove the support from the wheel axle and adjust the tyre pressure.
- 3 Wipe off the grease on the hydraulic ram piston rods.
- 4 Fit the pressure gauges again (seal with teflon tape).
- 5 Connect the sprayer to the tractor including hydraulics and electrics.
- 6 Check all hydraulic and electric functions.
- 7 Empty the remaining anti-freeze from the tank (if used).
- 8 Rinse the entire liquid circuit of the sprayer with clean water.
- 9 Fill with clean water and check all functions.

Troubleshooting

In cases where breakdowns have occurred, the same factors always seem responsible:

- Minor leaks on the suction side of the pump will reduce the pump capacity or stop the suction completely.
- A clogged suction filter will hinder or prevent suction so that the pump does not operate satisfactorily.
- Clogged up pressure filters will result in increasing pressure at the pressure gauge but lower pressure at the nozzles.
- Foreign bodies stuck in the pump valves results in these valves not closing tightly against the valve seat. This reduces pump efficiency.
- Poorly reassembled pumps, especially diaphragm covers, will allow the pump to suck air, resulting in reduced or no capacity.
- Hydraulic components that are contaminated with dirt result in rapid wear to the hydraulic system.

Therefore **always** check:

- 1 Suction, pressure and nozzle filters are clean.
- 2 Hoses for leaks and cracks, paying particular attention to the suction hoses.
- 3 Gaskets and O-rings are present and in good condition.
- 4 Pressure gauge is in good working order (Correct spray dosage depends on it).
- 5 EC operating unit functions properly. Use clean water to check.
- 6 Hydraulic components are maintained, clean and free from leaks. Refer to the boom operator's manual supplied with your sprayer documentation, either *FALCON* or *EAGLE PARALIFT Boom Operator's Manual*.

Problem	Probable cause	Control / Solution	
Liquid system			
No spray from boom when turned on	Air leak on suction line	Check if suction filter O-ring is sealing Check suction tube and fittings Check tightness of pump diaphragm and valve covers	
	Air in system	Fill suction hose with water for initial prime	
	Suction / pressure filters clogged	Clean filters Check yellow suction pipe is not obstructed or placed too near the tank bottom	
Lack of pressure	Incorrect assembly	Restrictor nozzle in self cleaning filter not fitted or incorrectly aligned Safety valve spring for self cleaning filter not tight Too little distance between yellow suction pipe and tank bottom	
		Pump valves blocked or worn	Check for obstructions and wear
		Defect pressure gauge	Check for dirt at inlet of gauge
	Pressure dropping	Filters clogged	Clean all filters. Fill with cleaner water If using powders, make sure agitation is on
Nozzles worn		Check flow rate and replace nozzles if it exceeds 10% variation from nominal rate	
Tank is air tight		Check vent is clear	
Sucking air towards end of tank load		Lower pump rpm	
Pressure increasing	Pressure filters beginning to clog	Clean all filters	
Formation of foam	Air is being sucked into system	Check tightness/gaskets/O-rings of all fittings on suction side	
	Excessive liquid agitation	Reduce pump rpm Check safety valve for self cleaning filter is tight Ensure returns inside tank are present	
			Use foam damping additive
Liquid leaks from bottom of pump	Damaged diaphragm	Replace. See <i>Changing valves</i> and <i>Changing diaphragms</i> (Page 13)	

Problem	Probable cause	Control / Solution
EVC operating unit		
Operating unit not functioning	Blown fuse(s)	Check mechanical function of microswitches Use cleaning/lubricating agent if the switches do not operate freely
		Check motor (450 - 500 mA MAX) Change motor if over
	Wrong polarity	Brown = positive (+) Blue = Negative (-)
	Valves not closing properly	Check valve seals for obstructions Check microswitch plate position Loosen screws holding plate a ½ turn
	No power	Wrong polarity Check that Brown is (+), Blue is (-) Check printed circuit board for dry solder joints or loose connections Check fuse holder is tight around fuse
Foam marker		
Compressor will not start	Poor power supply	Check battery (must be 12 V) and wiring
	Blown fuse	Change external fuse
	Defective relay	Open compressor box and check relay for corrosion
No liquid to foam generator	Blown fuse	Open compressor box and check fuse located on printed circuit board
	Solenoid valve not opening	Check wiring at printed circuit board for corrosion or loose connections
	Filter blocked	Dismantle and clean
Foam quality inconsistent	Recommendations not followed	See <i>Foam marker</i> (P11 - Navigator Operators Manual), and Foam Concentrate label.
Blob interval inconsistent	Adjustment valve gummed up	Flush system
Foam liquid in air lines	Non-return valve in line gummed up	Dismantle and clean

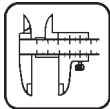

Specifications

1 Nm = 0.738 lbf-ft

1 bar = 100 kPa = 14.5 psi

TORQUE SETTINGS

Wheel studs

20 mm 337 Nm

Drawbar bolts

Hitch M16 190 Nm Chassis 750

363 / 463 pump

Valve cover bolts 90 Nm Diaphragm bolt 90

General bolts

M12 bolts 77 Nm M16 190
M18 bolts 269 Nm M20 370

TEMPERATURE

Operating temperature range: 2° - 40° C (36° - 104° F)

PRESSURE

Operating pressure for safety valve: 15 bar

MAX Pressure on the pressure manifold: 15 bar

MAX Pressure on the suction manifold: 15 bar

FLOW

EVC

Bypass flow under the EVC pressure adjusting motor (Pressure motor adjusted for full pressure): 0-1 l/m

Self Cleaning Filter

Bypass flow for each restrictor (Pressure @ 3 bar):

Green - 37 l/m Black - 26 l/m
White - 18 l/m Red - 13 l/m

Agitators

Combined flow from both agitators @ 3 bar:

2.5 mm - 16 l/m 3.0 mm - 25 l/m

DIMENSIONS

Always measure and weigh actual sprayer.

Dimensions are dependant on boom, suspension, wheels, tank and drawbar variations, and added accessories.

Boom Height (mm): 500 - 1750

Track Width (mm): 1500 - 3000

PUMP CAPACITY (at various rpms)

363/10.0/540 PRESSURE (bar)	200	300	400	500	540	600
	CAPACITY (l/min)					
0	73	107	141	178	194	211
2	72	105	140	175	189	207
4	71	103	139	172	186	205
6	70	102	138	169	184	203
10	68	100	135	166	182	200
15 (MAX)	66	98	132	164	178	197

463/10.0/540 PRESSURE (bar)	200	300	400	500	540	600
	CAPACITY (l/min)					
0	109	156	207	257	276	305
2	103	152	202	252	270	299
4	101	149	198	246	265	295
6	99	146	195	242	263	289
10	94	142	192	236	256	286
15 (MAX)	91	136	184	230	248	276

363/5.5/1000 PRESSURE (bar)	300	500	700	800	900	1000
	CAPACITY (l/min)					
0	61	103	144	164	186	201
2	59	100	140	160	179	191
4	58	98	138	155	176	188
6	57	96	134	153	173	186
10	55	94	130	148	168	180
15 (MAX)	53	89	126	144	163	174

MATERIALS AND RECYCLING

Tank HDPE Hoses PVC / Rubber

Valves Mainly glass-filled PA Fittings PA

When the equipment has completed its working life, it must be thoroughly cleaned. Tank, hose and synthetic fittings can be incinerated at an authorised disposal plant. Metallic parts can be scrapped. Always follow local legislation regarding disposal.

FILTERS

MESH	COLOR	GAUZE SIZE (mm)
30	Green	0.58
50	Blue	0.30
80	Red	0.18
100	Yellow	0.15

Tyre Size	Ply or Load Rating	TYRE LOAD LIMITS (Kg) AT VARIOUS COLD INFLATION PRESSURES (kPa)								
		Values specified apply to Olympic Gripster R-1 bias / radial tyres fitted as singles and used at speeds up to 30km/h For other brands of tyres please contact your supplier for recommended limits.								
		85 kPa	100 kPa	120 kPa	140 kPa	160 kPa	180 kPa	200 kPa	220 kPa	240 kPa
14.9-24	6 / 8	1140*	1250	1390	1520 (6)	1640	1760 (6)	-	-	-
14.9-28	6 / 10	1210*	1330	1480	1620 (6)	1750	1880 (8)	2000	2010	2110 (10)
16.9-28	6 / 8 / 12	1470*	1650*	1800 (6)	1970	2130 (8)	2280	2425 (10)	2560	2700 (12)
18.4-30	6 / 8 / 10	1820*	2005 (6)*	2230	2440 (8)	2640	2825 (10)	3000	3180 (12)	-
18.4-38	8 / 10 / 14	2050*	2250 (6)*	2505	2740 (8)	2965	3180 (10)	-	-	-
20.8-38	8 / 10 / 14	2480*	2725*	3040 (8)	3320	3590 (10)	3840	4080 (12)	4220 (14)	-
20.8-42	10	2610*	2875*	3200	3500	3780 (10)	-	-	-	-
Minimum cold inflation pressures are as indicated, (Exception: loads marked* are only permissible for Gripster tyres used in straight drawbar pull applications). (x) denotes ply rating for which loads and inflation pressure are maximum.										
For operations which do not require sustained high torque, the following load limits at various speeds apply with no change in inflation pressure.										
		Maximum Speed								
		15 km/h	25 km/h	30 km/h	40 km/h					
% Increase in Loads		+20%	+10%	Same as table	-10%					

PLUMBING DIAGRAM 5000L HARDI NAVIGATOR WITH VACUUM GRANNI POT

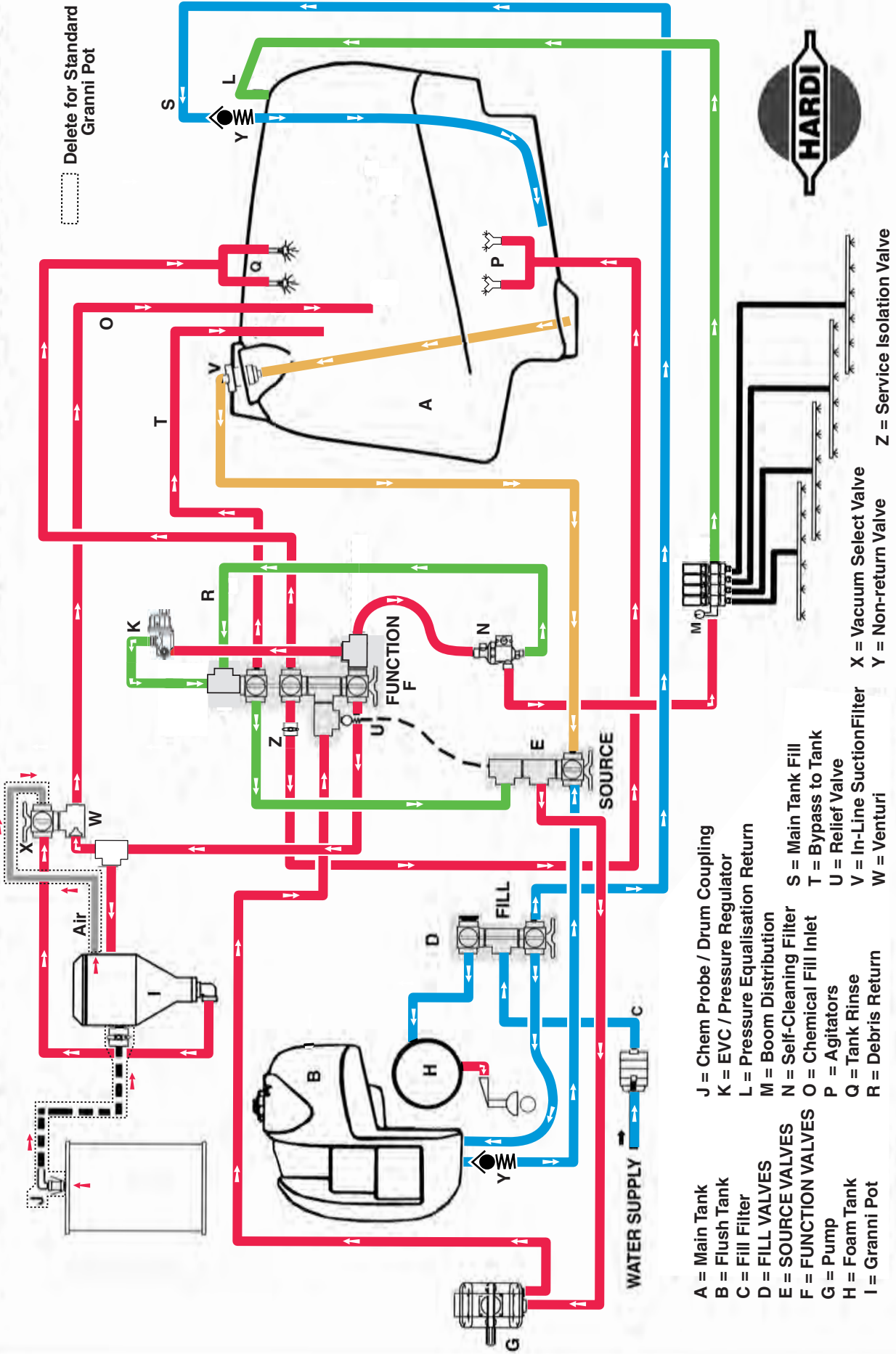

- A = Main Tank
- B = Flush Tank
- C = Fill Filter
- D = FILL VALVES
- E = SOURCE VALVES
- F = FUNCTION VALVES
- G = Pump
- H = Foam Tank
- I = Granni Pot
- J = Chem Probe / Drum Coupling
- K = EVC / Pressure Regulator
- L = Pressure Equalisation Return
- M = Boom Distribution
- N = Self-Cleaning Filter
- O = Chemical Fill Inlet
- P = Agitators
- Q = Tank Rinse
- R = Debris Return
- S = Main Tank Fill
- T = Bypass to Tank
- U = Relief Valve
- V = In-Line Suction Filter
- W = Venturi
- X = Vacuum Select Valve
- Y = Non-return Valve
- Z = Service Isolation Valve



Replacement Parts

This section is to be used to help identify the replacement part numbers of many common parts on the HARDI NAVIGATOR sprayer - it is not as comprehensive as the *Spare Parts* manual at your HARDI dealer.

So if a part is not covered in this section, or is difficult to determine, you will need to contact your HARDI dealer.

Every part illustrated in this section has a number or is shown as part of a group of parts in a numbered kit.

This number is the HARDI parts number for the part or kit of parts.

Note that drawing numbers used in this section do not represent any HARDI parts drawing numbers - they are simply used for cross-referencing within this manual.

Title	Drawing	Page	Title	Drawing	Page
363 Pump	Drg 1	25	Chassis	Drg 16	40
363 1000 Pump	Drg 2	26	Chassis (Detail)	Drg 17	41
463 Pump	Drg 3	27	Chassis (Detail)	Drg 18	42
463 1000 Pump	Drg 4	28	Axles - Adjust Width / Suspension	Drg 19	43
ACE Pump	Drg 5	29	Axles - Non-Suspended	Drg 20	44
Self-Cleaning Filter / Fast Fill Filter	Drg 6	30	Axles - Fixed Width / Suspension	Drg 21	45
Foam , Handwash and Flush Tanks	Drg 7	31	Short and Long Paralift	Drg 22	46
Main Tank and Fittings	Drg 8	32	Transport Brackets	Drg 23	47
Plumbing Fittings	Drg 9	33	EVC Operating Unit	Drg 24	48
SELECT FILL Valve Assembly	Drg 10	34	EVC Distribution Valve and Control Box	Drg 25	49
SELECT FUNCTION Valve Assembly	Drg 11	35	Mudguards and Hubs	Drg 26	50
SELECT SOURCE Valve Assembly	Drg 12	36	Granni Pot Side Mount	Drg 27	51
Smart Valve Parts	Drg 13	37	Hoses and Fasteners	Drg 28	52
Granni Pot Venturi Manifold	Drg 14	38	Hardi Nozzles	Drg 29	53
Safety Relief Valve	Drg 15	39			

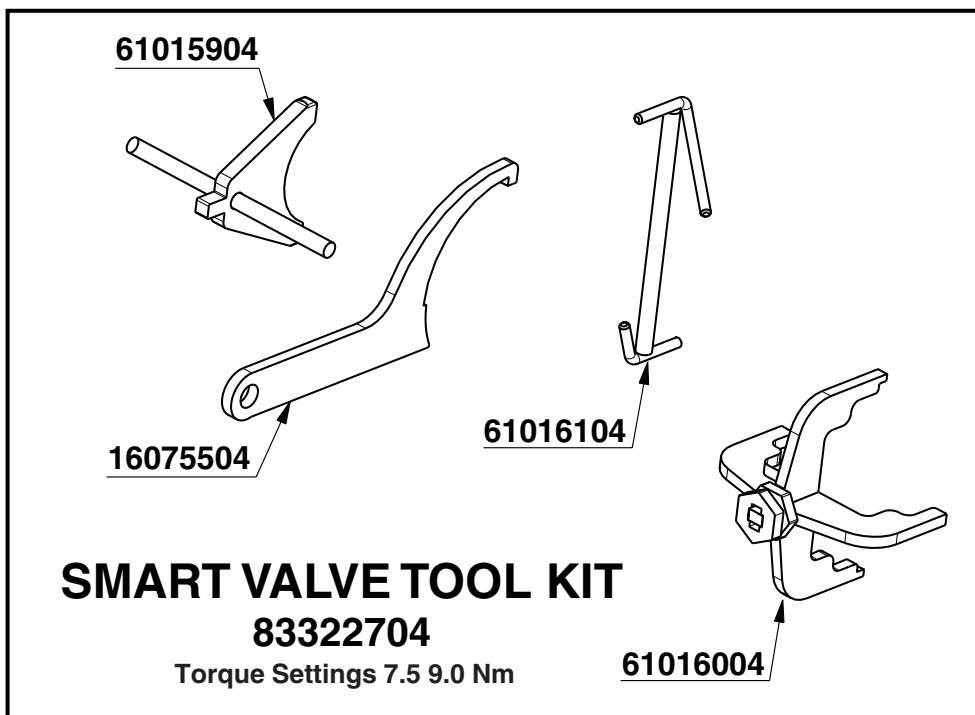

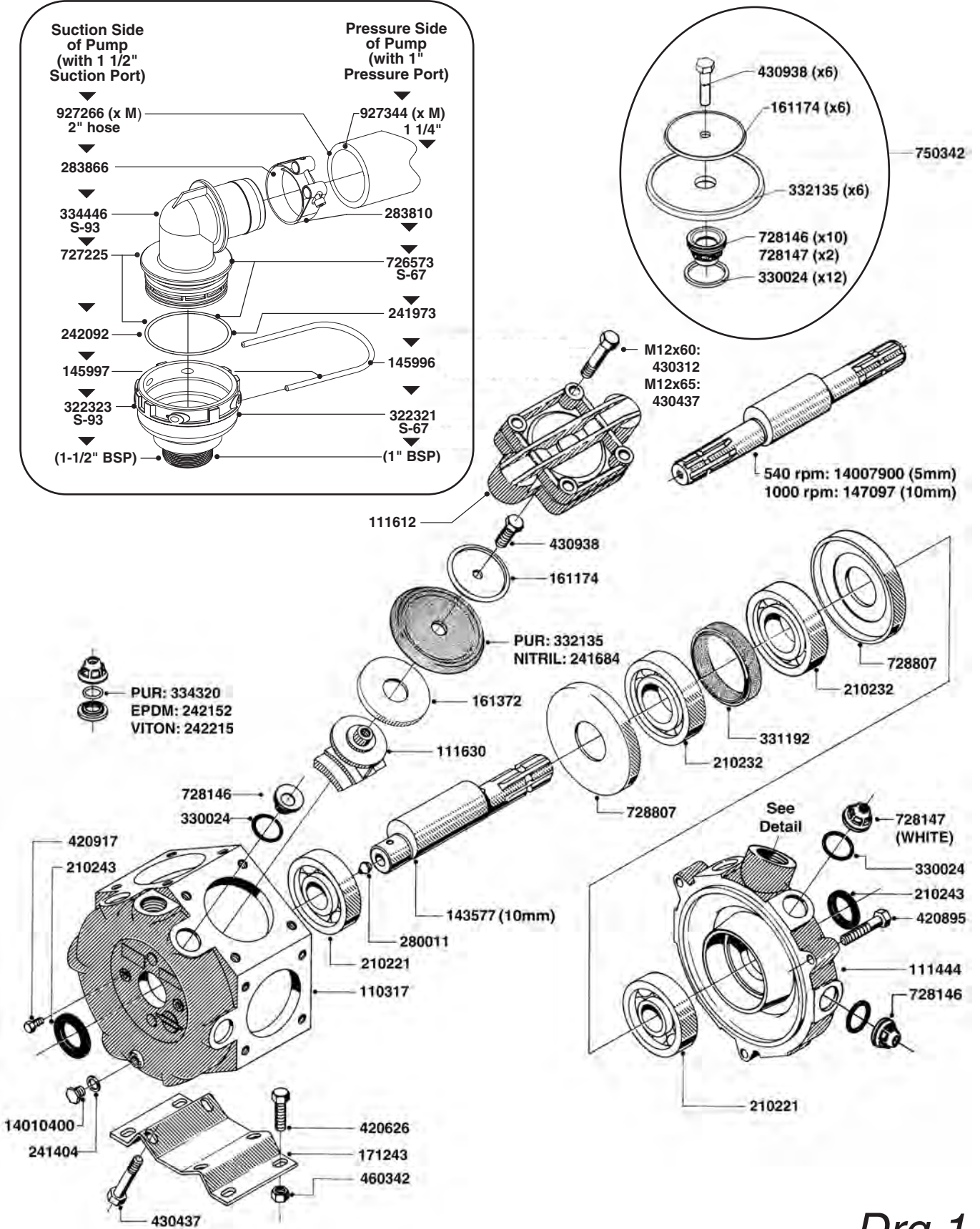

Drig 1
363 540 RPM PUMP

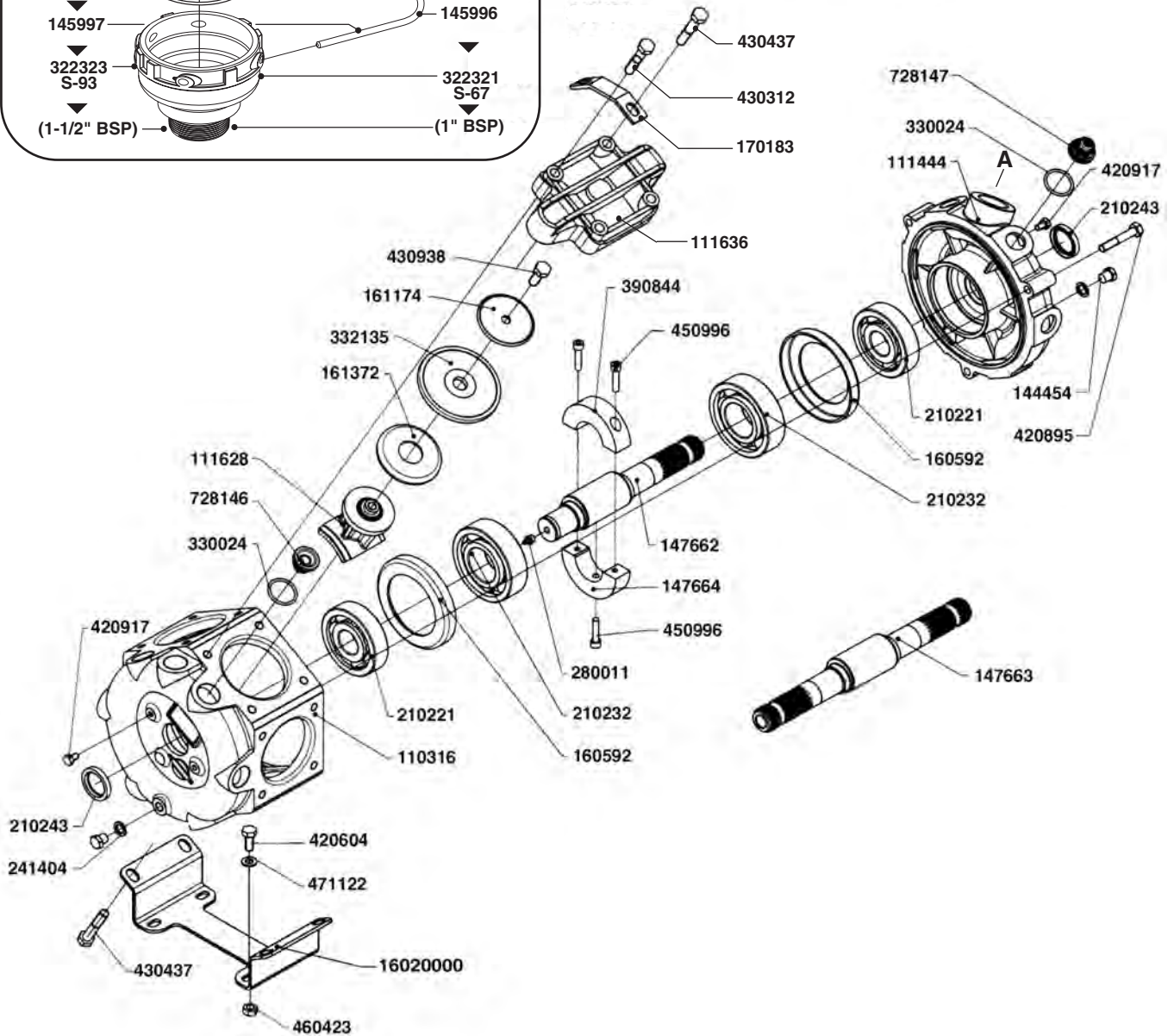
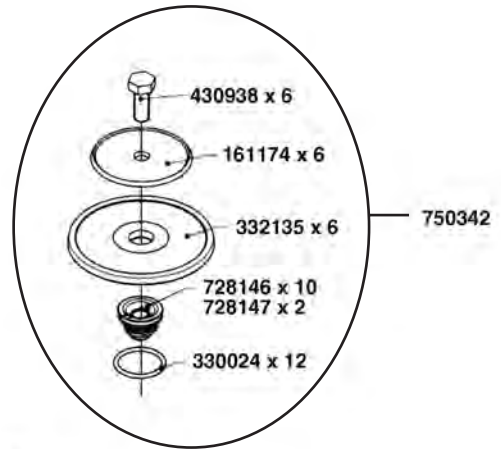
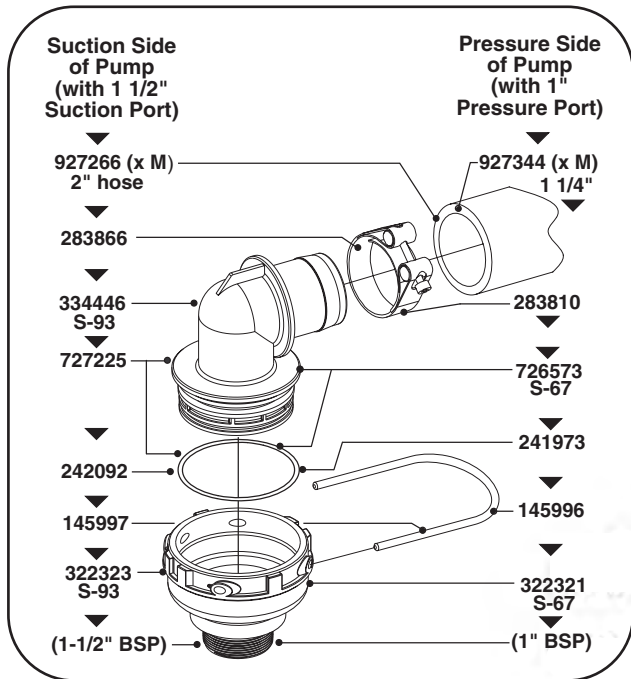

Drg 2

363 1000 RPM PUMP

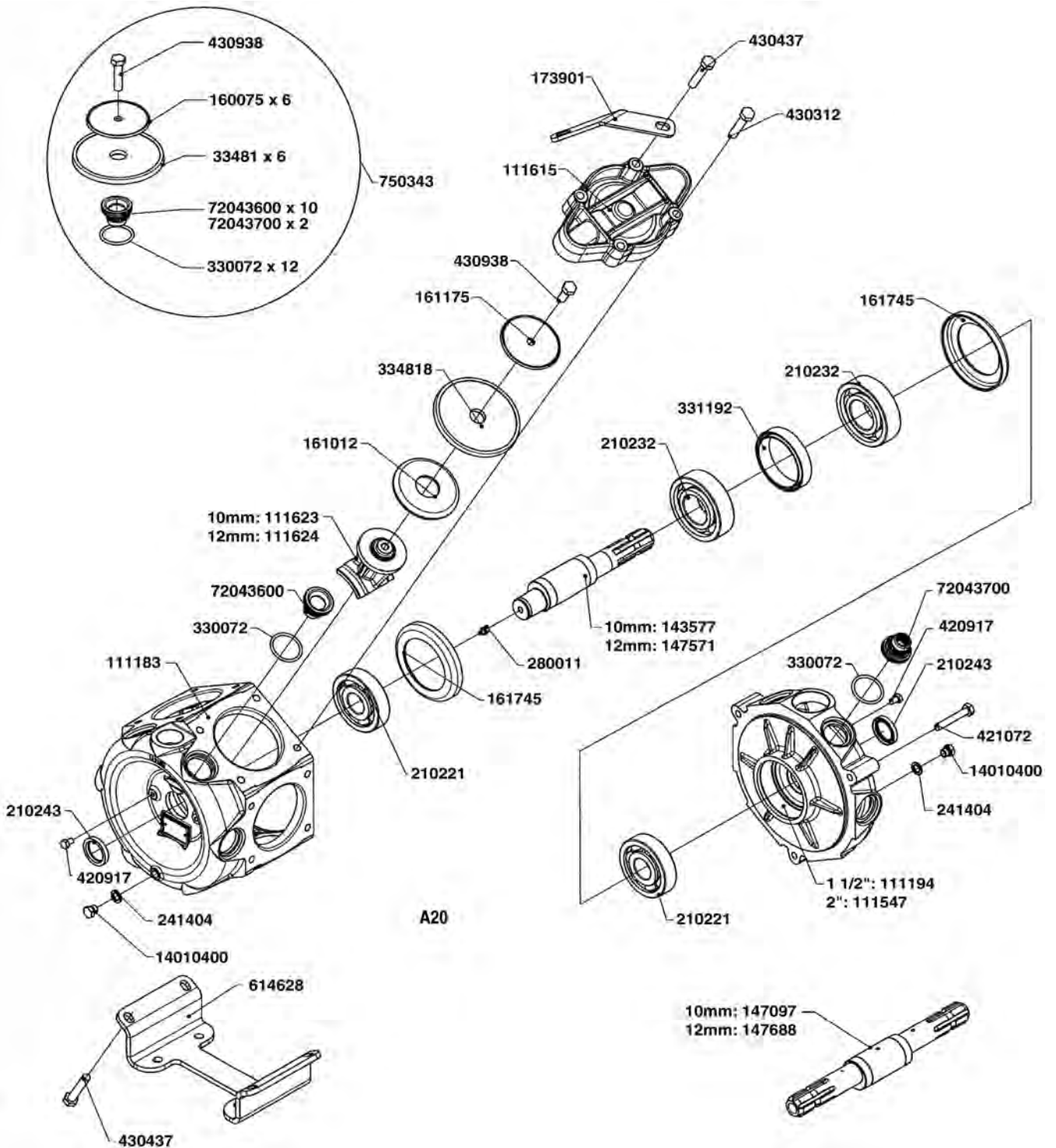

Dr3
463 540 RPM PUMP

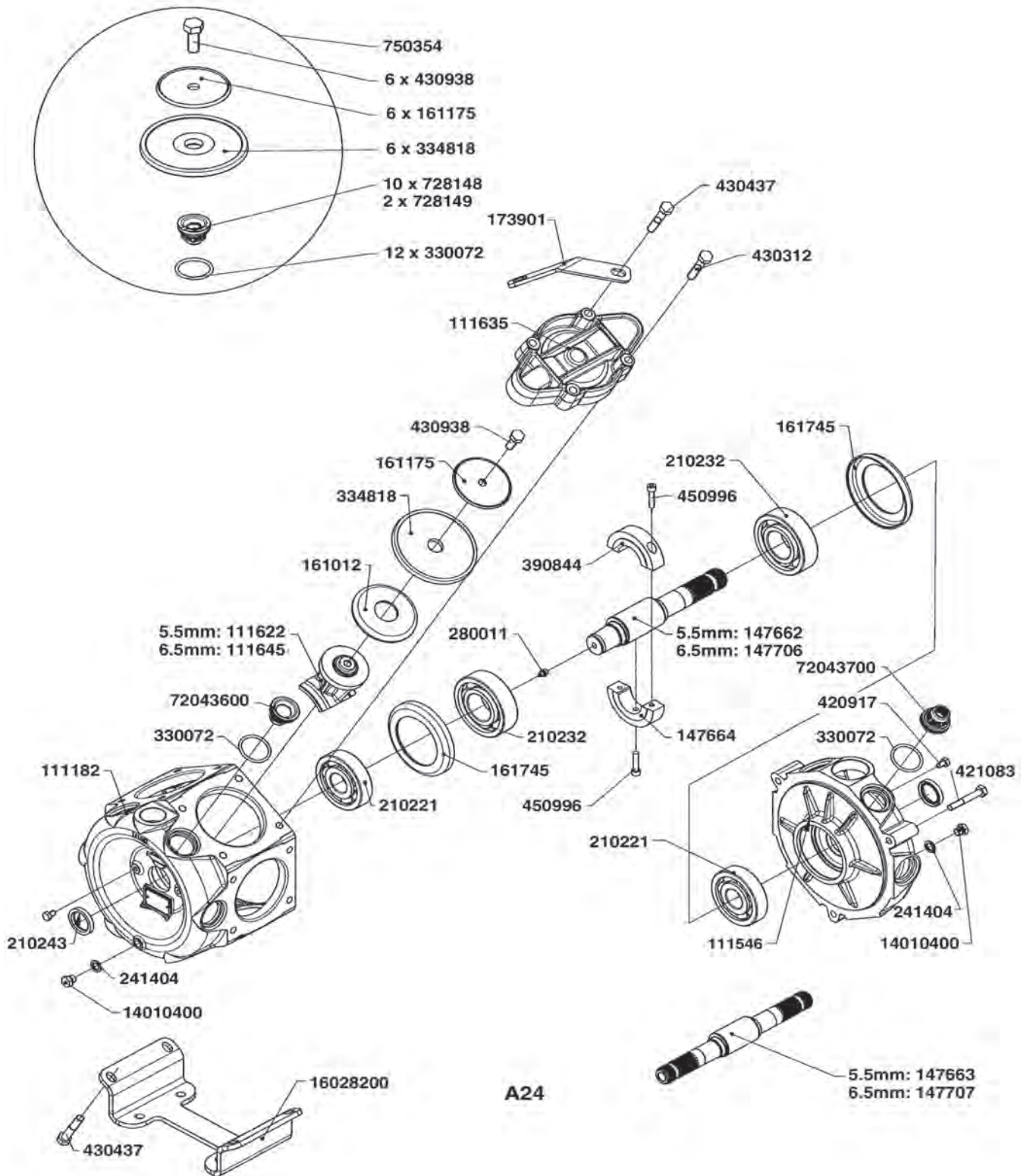

Drp 4

463 1000 RPM PUMP

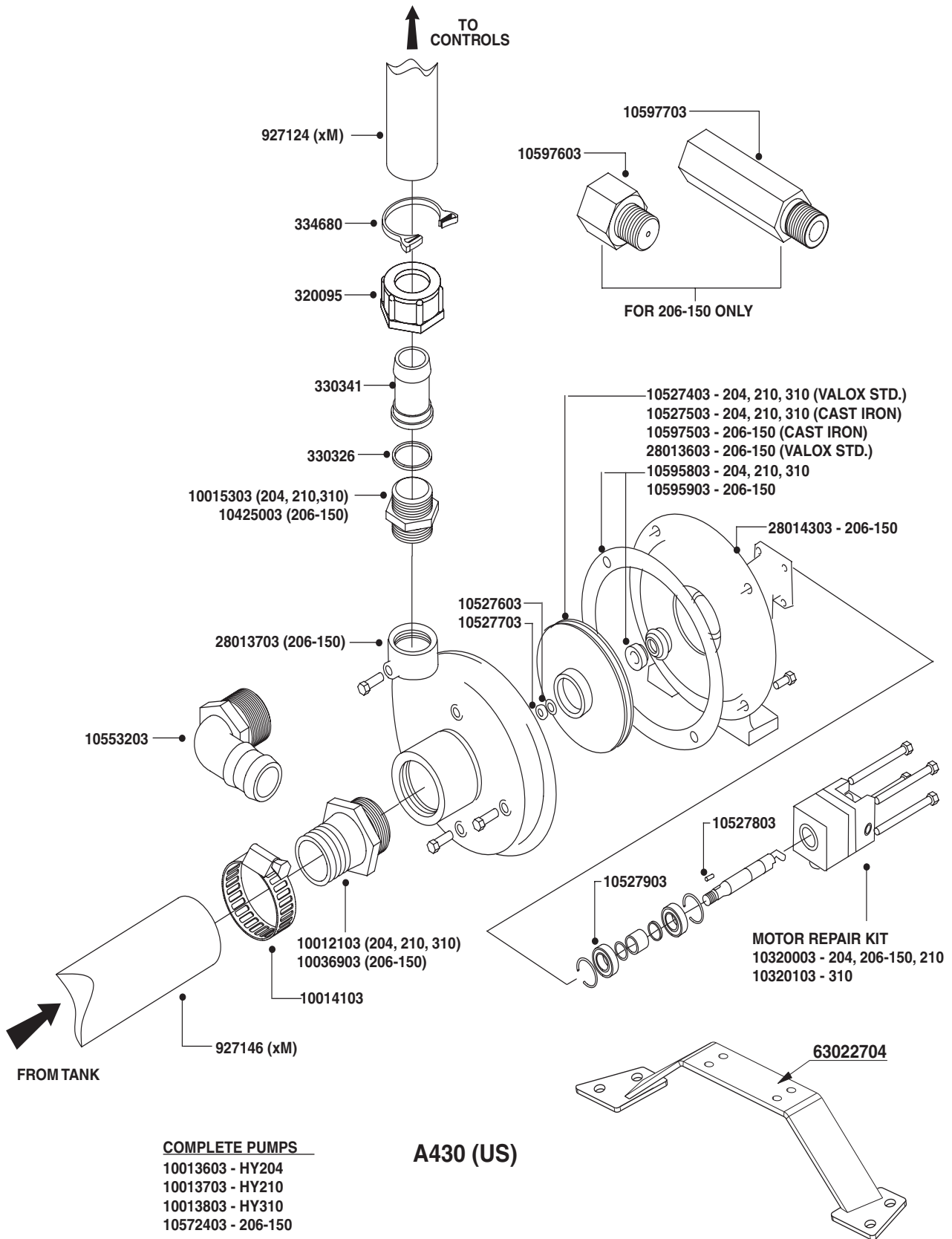

Drg 5
ACE CENTRIFUGAL PUMPS

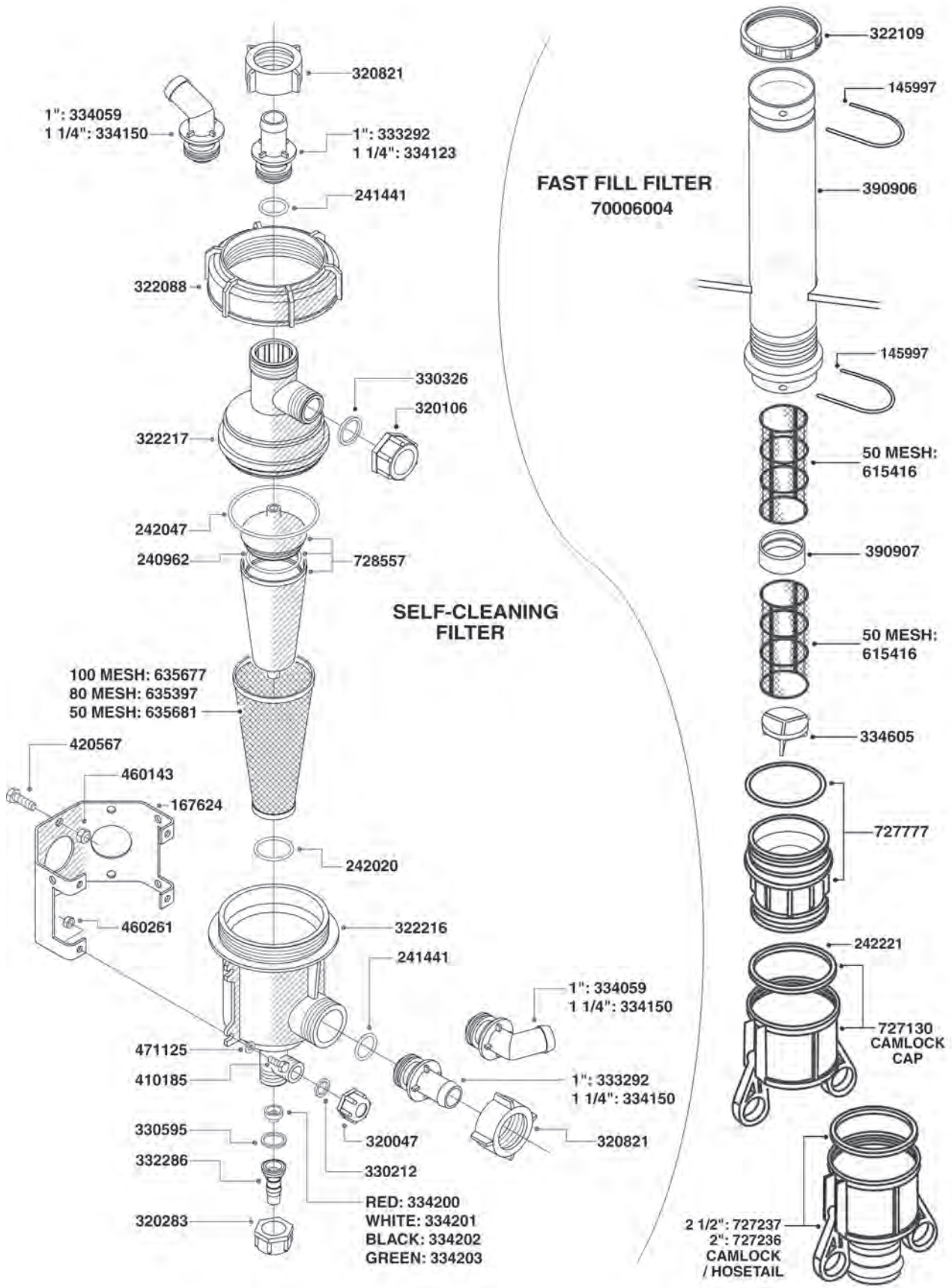

Drp 6
FILTERS

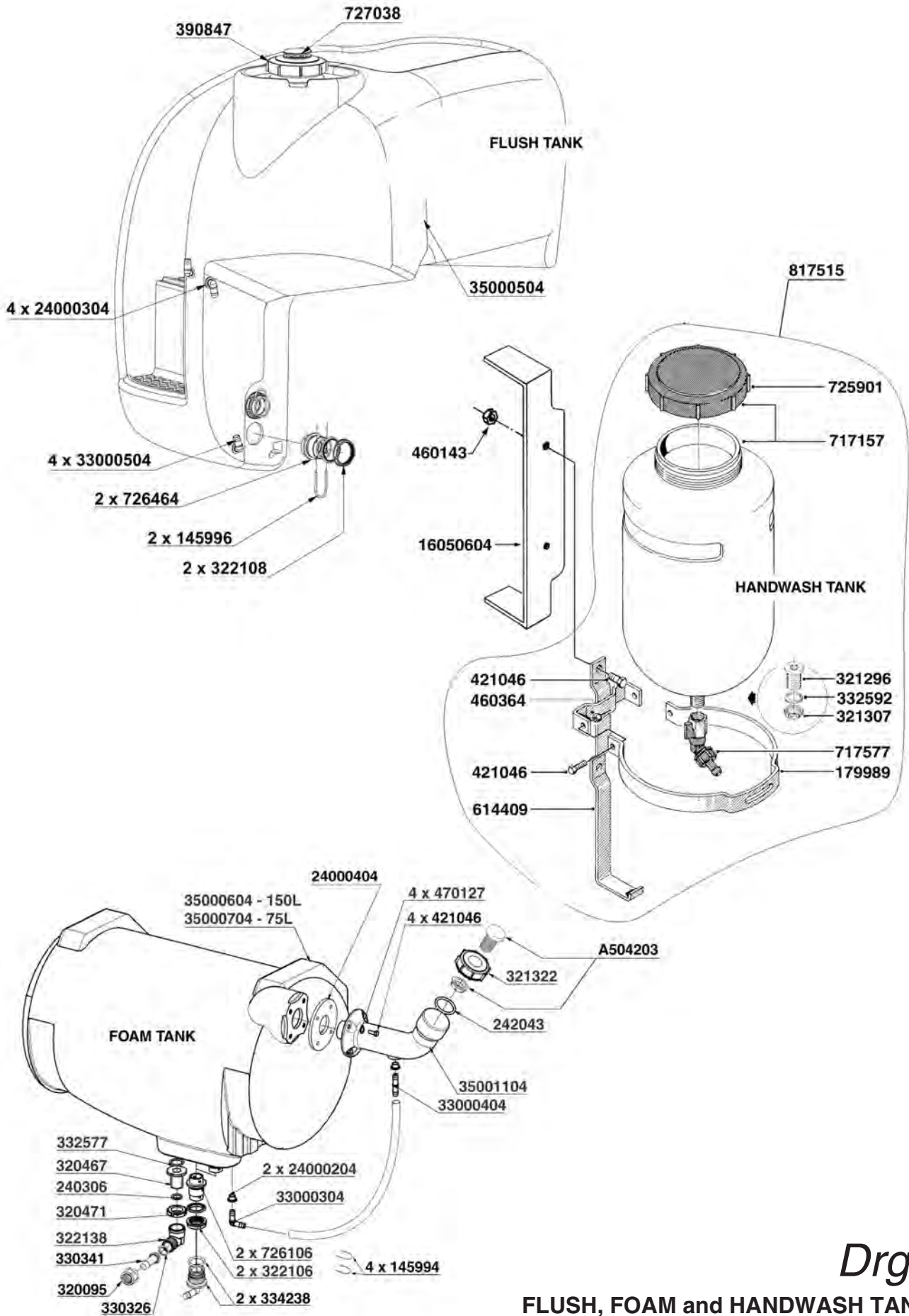

Drq 7
FLUSH, FOAM and HANDWASH TANKS

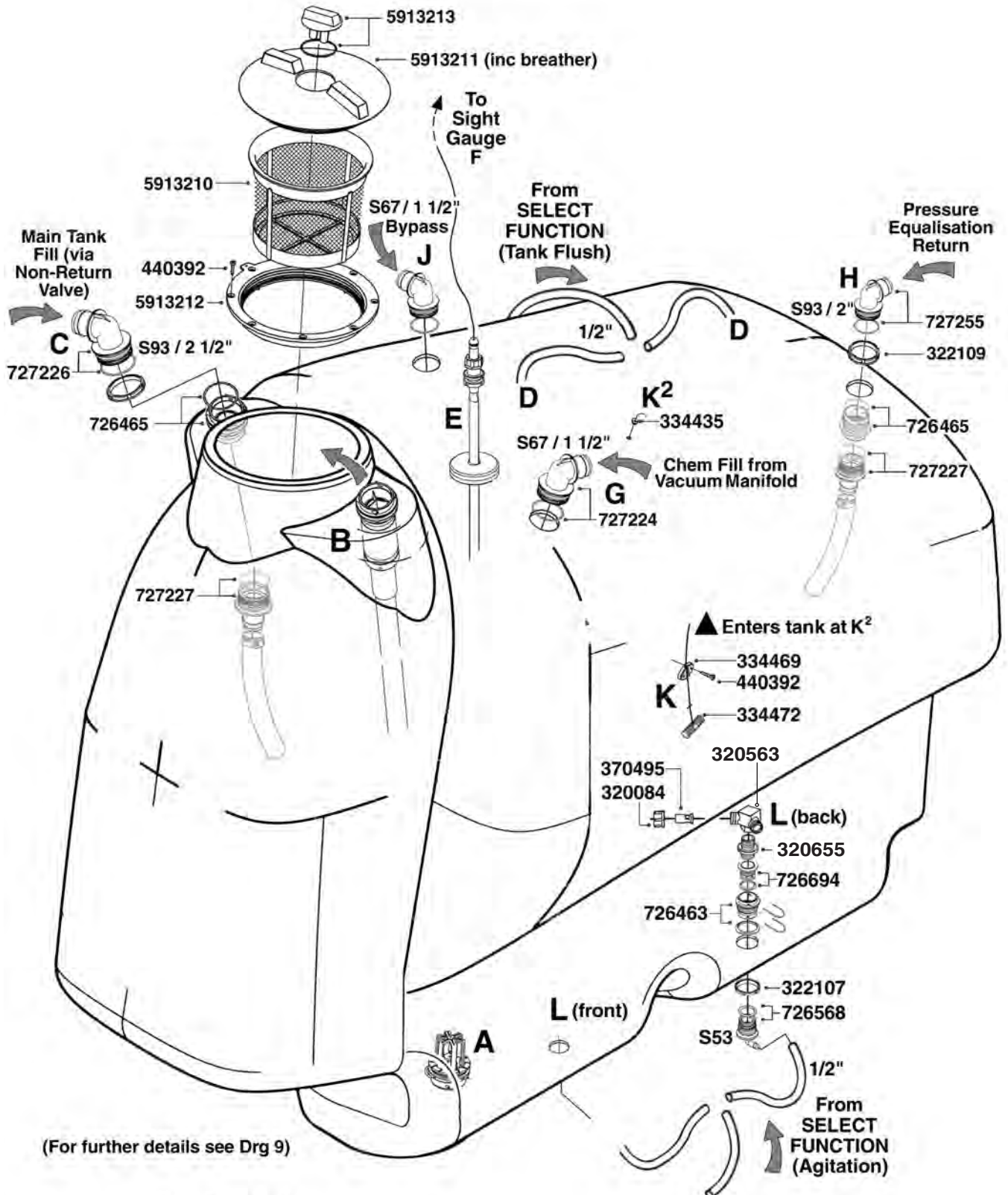

- A = Tank Drain Outlet
- B = Suction Filter
- C = Main Tank Fill
- D = Tank Flush (Front and Back)
- E = Level Indicator Float
- F = Sight Gauge

- G = Chemical Fill
- H = Pressure Equalisation Return
- J = Bypass
- K = Tank Drain Cord
- L = Agitation (Front and Back)

Drg 8 MAIN TANK AND FITTINGS

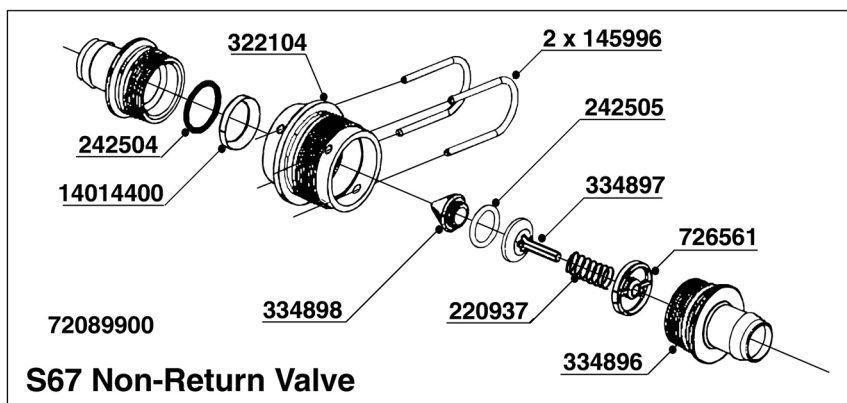
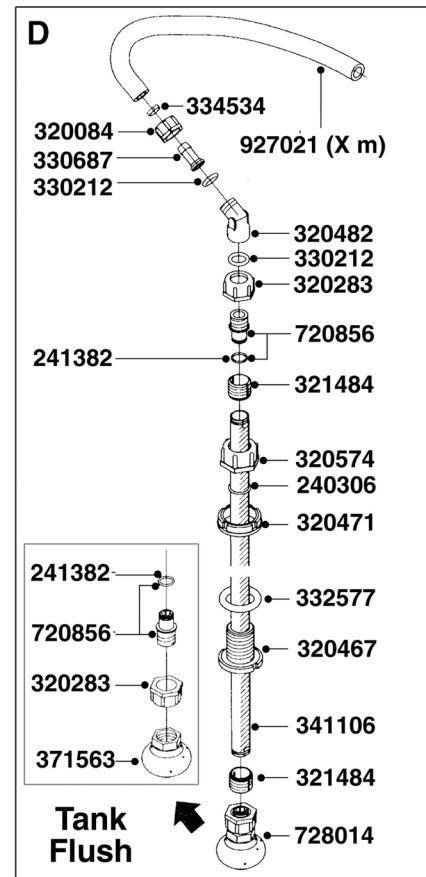
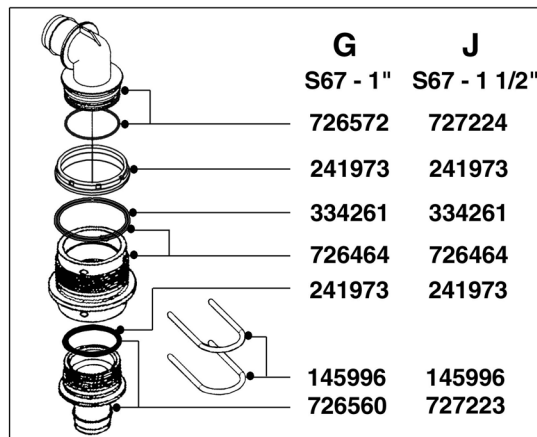
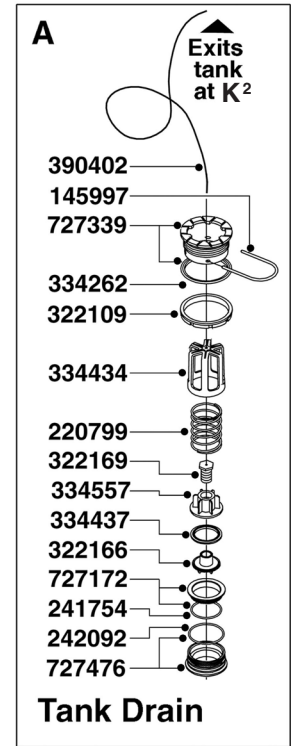
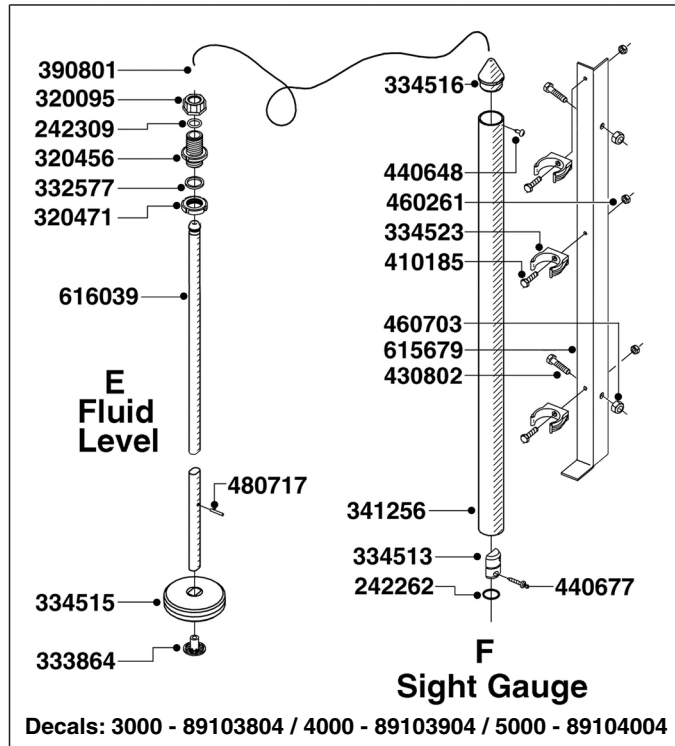
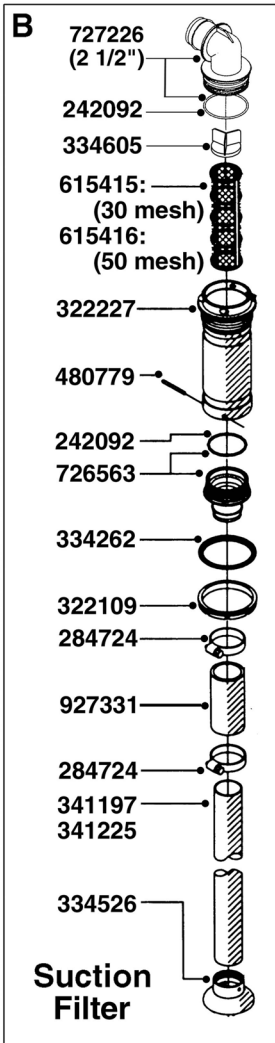

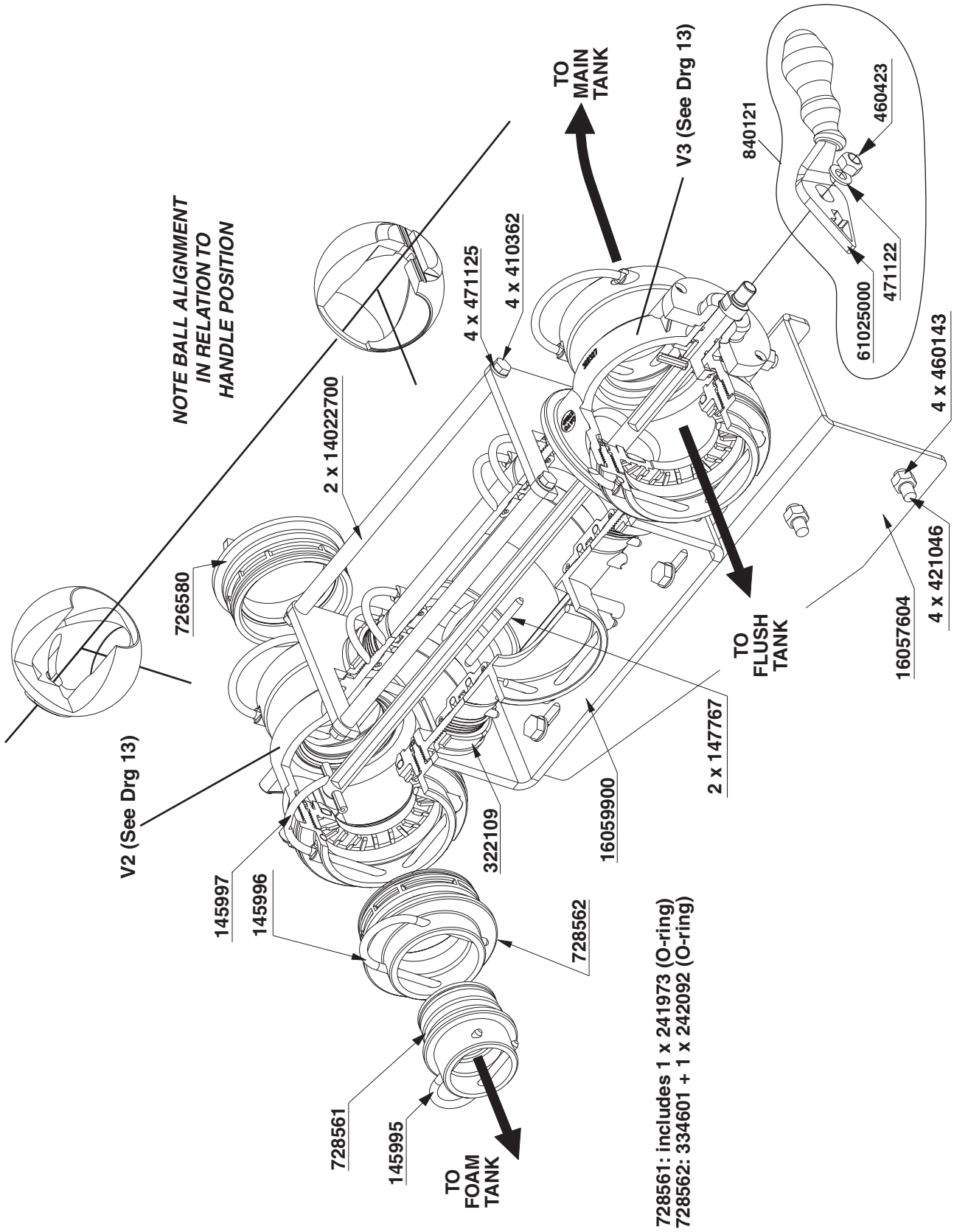

Drng 10
SELECT FILL VALVE

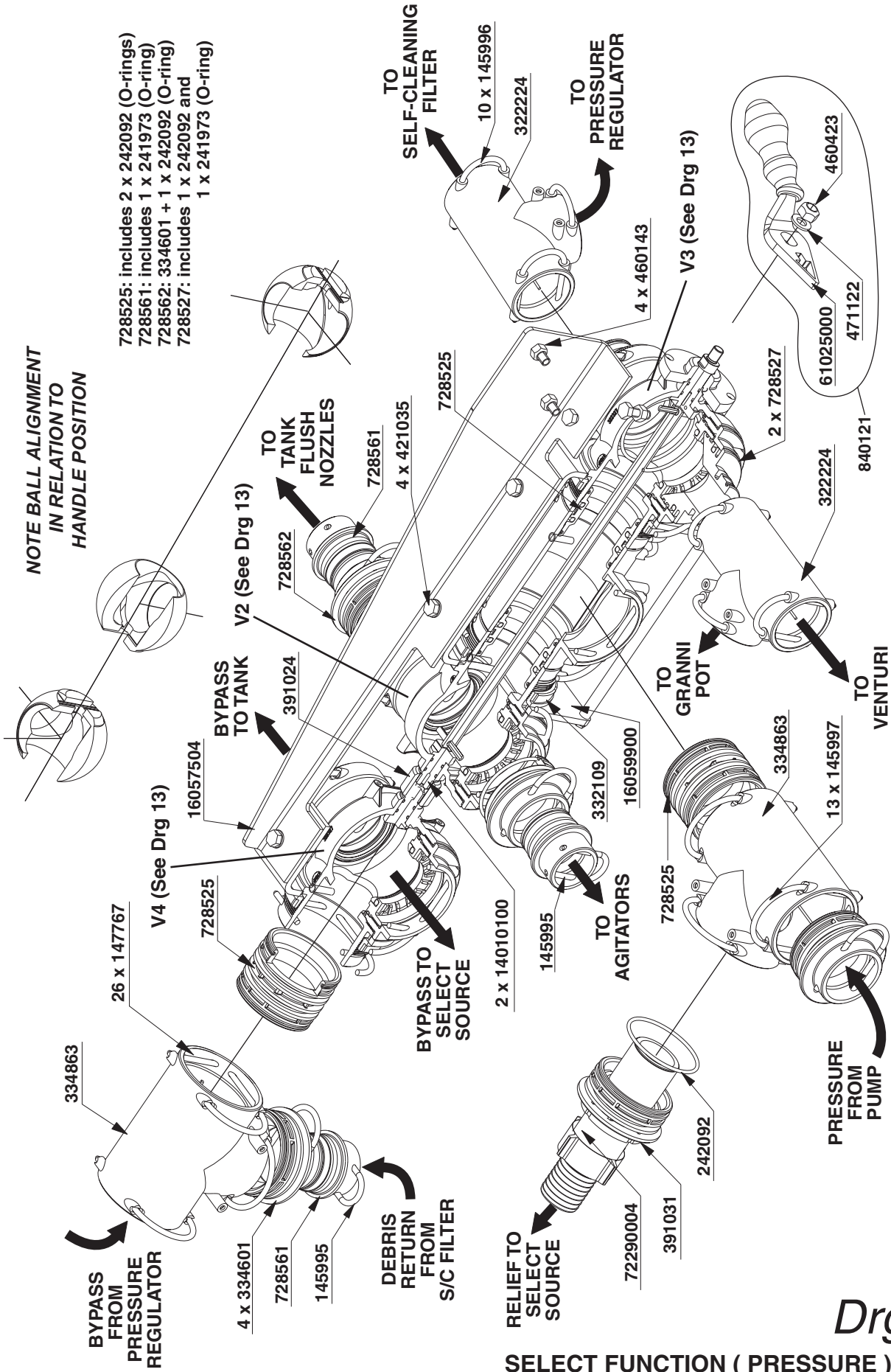

Drg 11
SELECT FUNCTION (PRESSURE) VALVE

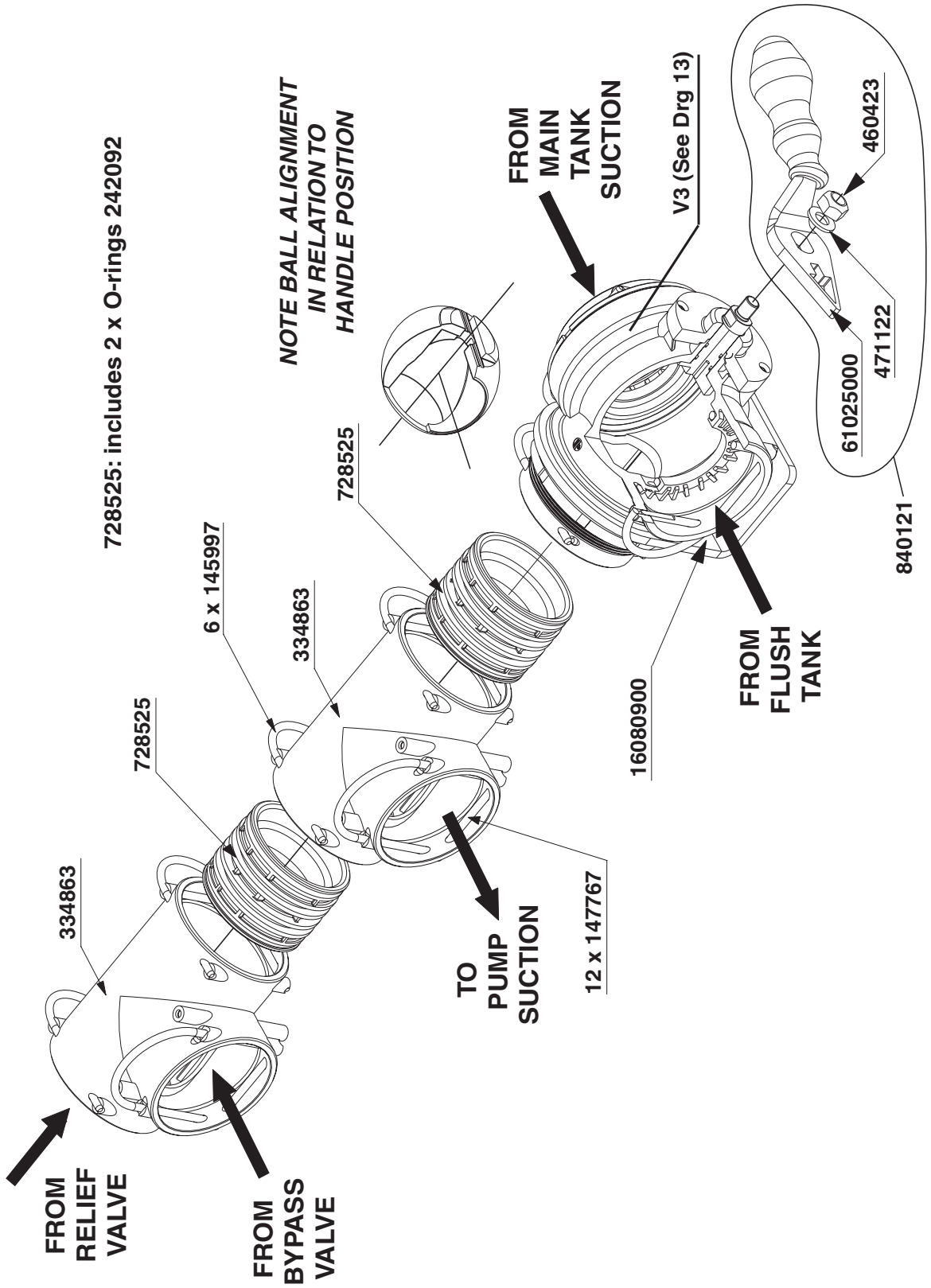

Drg 12

SELECT SOURCE (SUCTION) VALVE

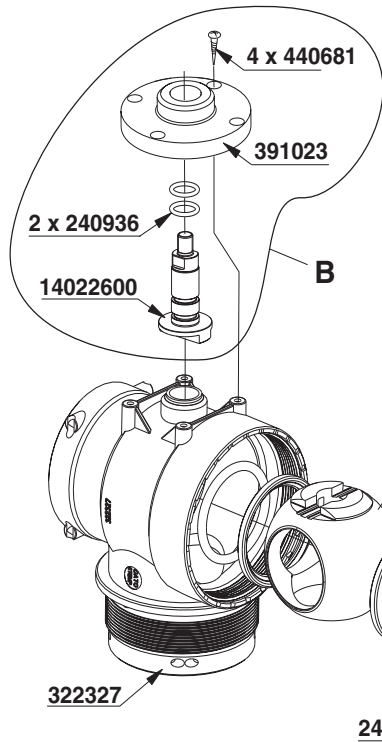
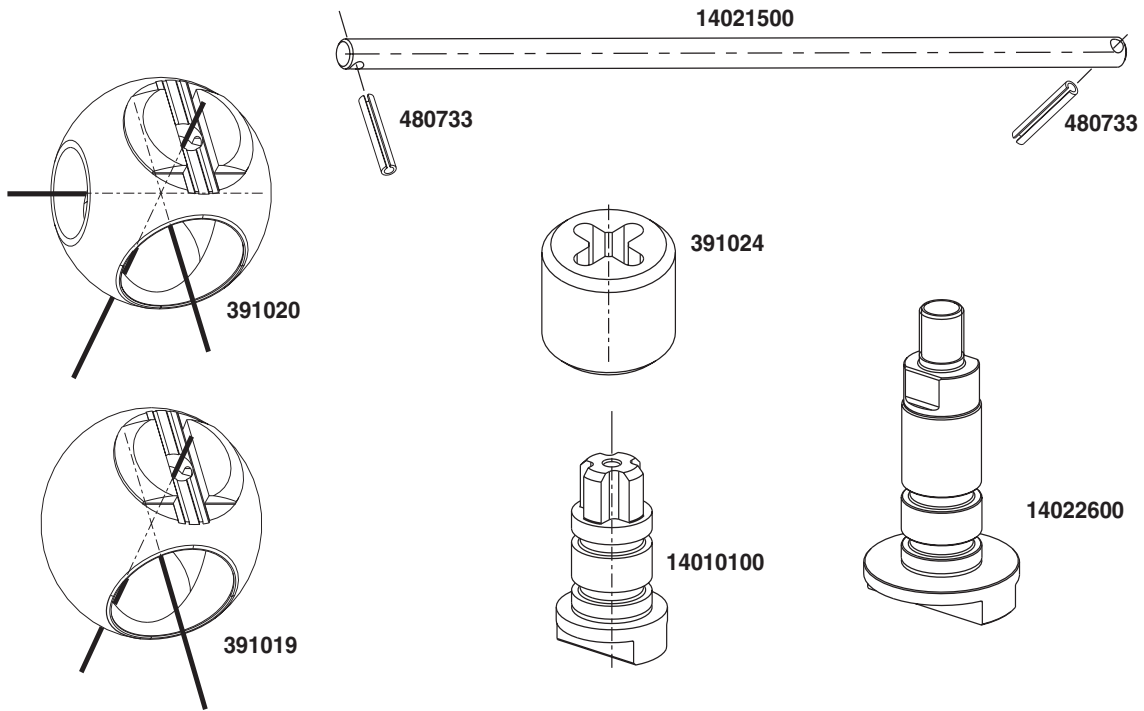

		A	B	C
72137900	V1	391020	YES	-
72138000	V2	391019	-	YES
72138600	V3	391019	YES	-
72142700	V4	391020	-	YES

IMPORTANT!
 CAREFULLY NOTE ORIENTATION OF
 BALLS AND VALVE ASSEMBLIES
 IN DRGS 10, 11 AND 12

Drg 13
SMART VALVE PARTS BREAKDOWN

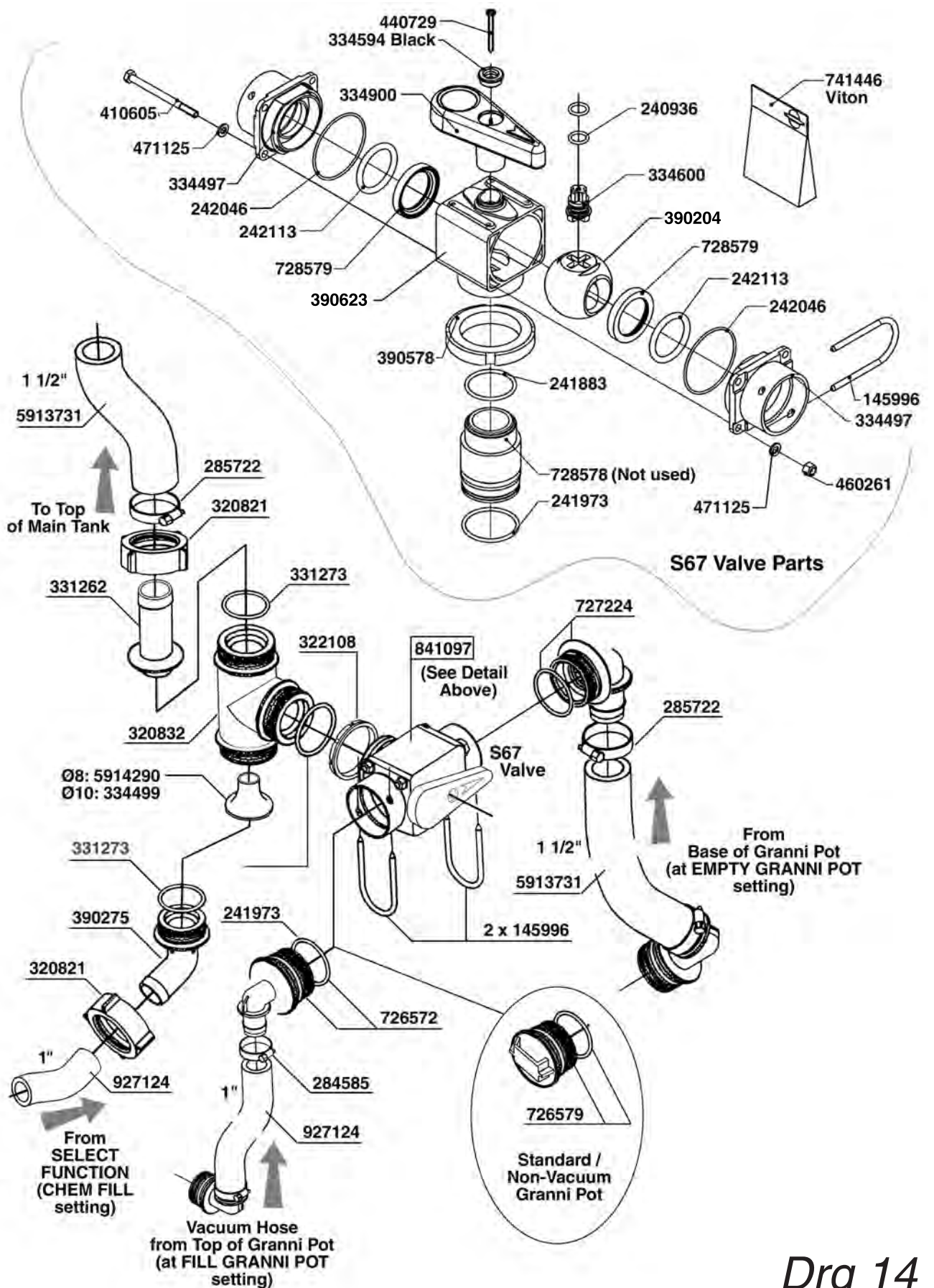

Drq 14
GRANNI POT VENTURI MANIFOLD

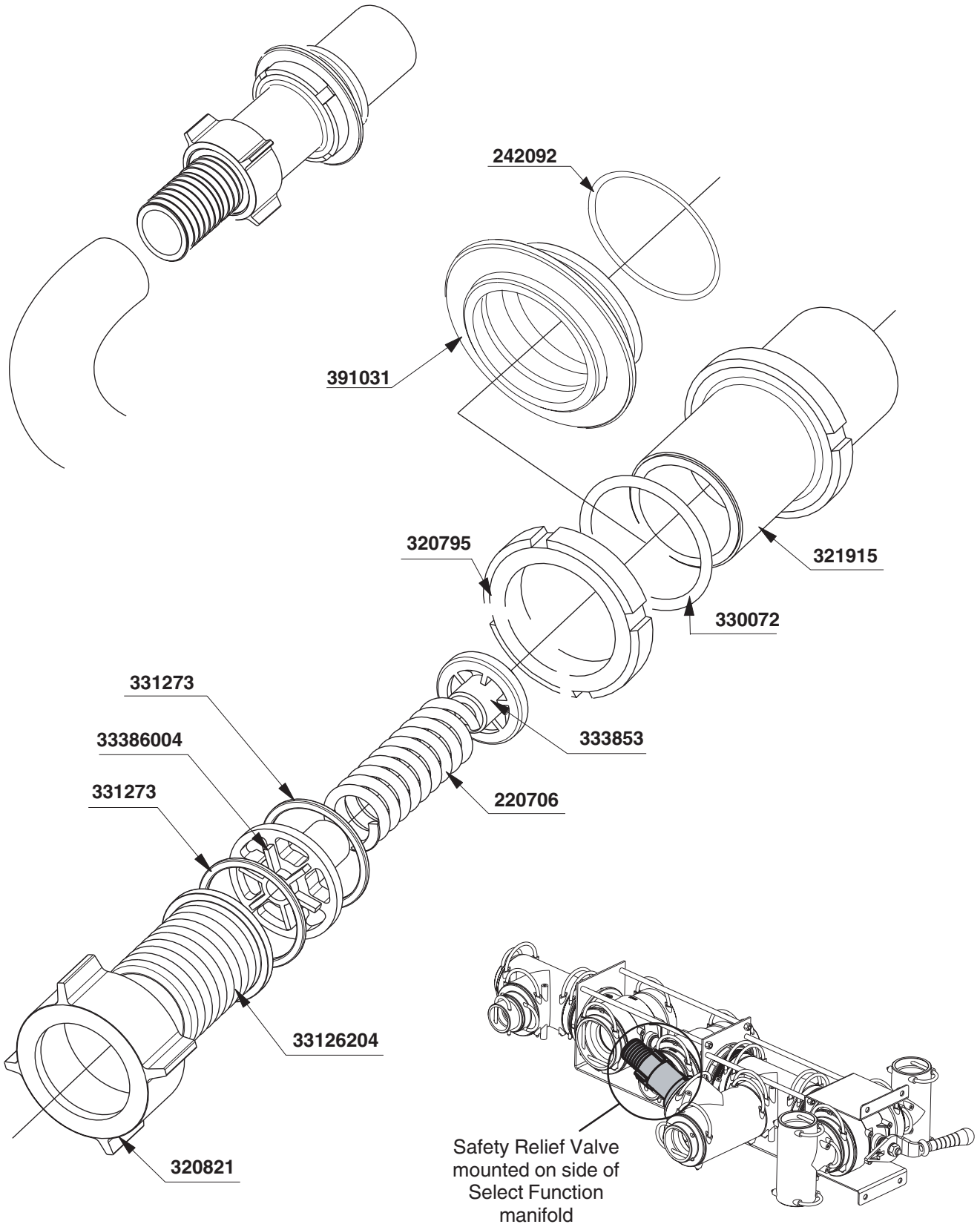

Drq 15
15 BAR SAFETY RELIEF VALVE

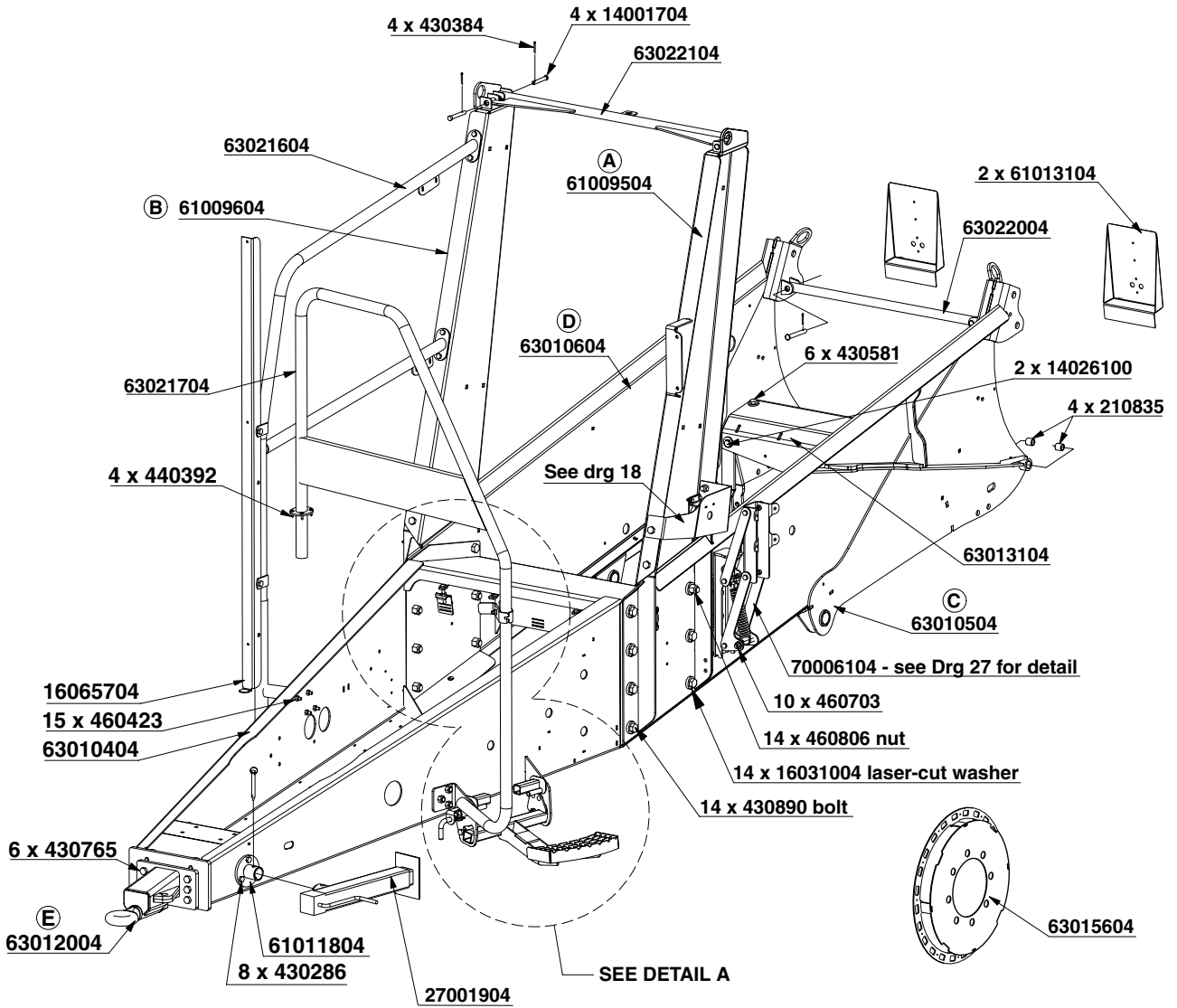

	A	B	C	D	E
83306904 - 5000 L	61009704	61009804	63010204	63010304	63011904
83307004 - 4000 L	61009504	61009604	63010504	63010604	63012004
83307104 - 3000 L	61009304	61009404	63010804	63010904	63012104

Drg 16
NAVIGATOR CHASSIS

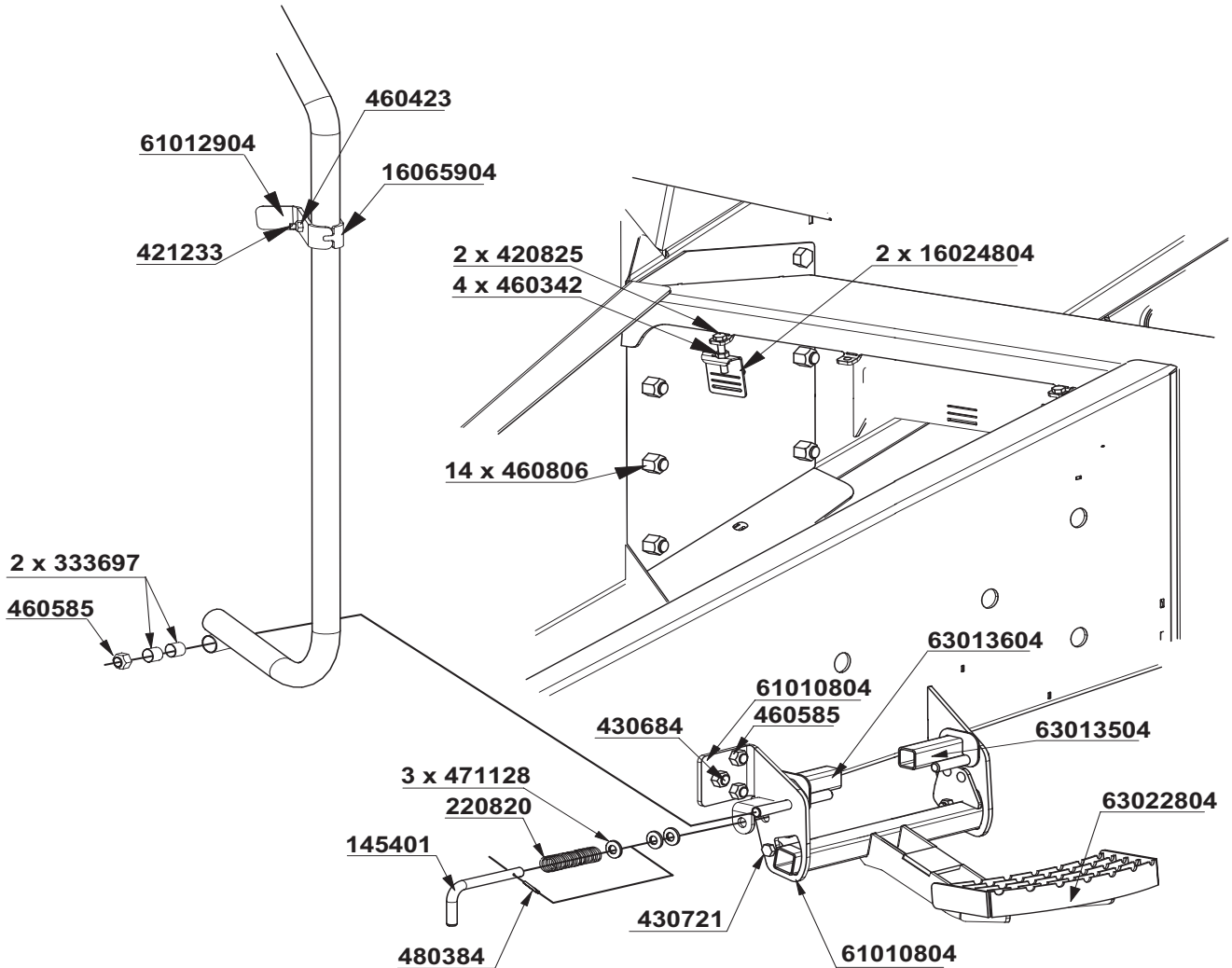

DETAIL: A
Fold-Down Access Step
and Hand Rail

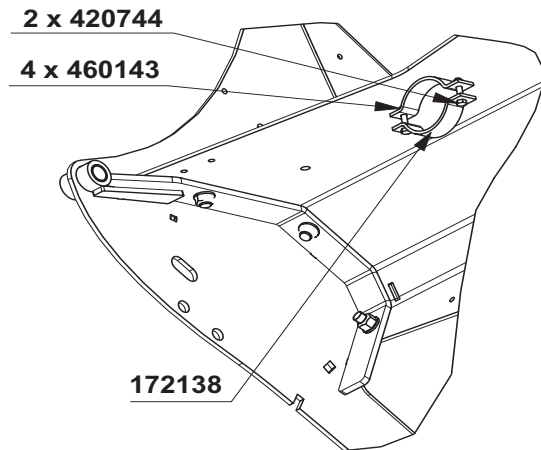

DETAIL: B
Hydraulic Accumulator Mount

Drg 17
CHASSIS DETAIL

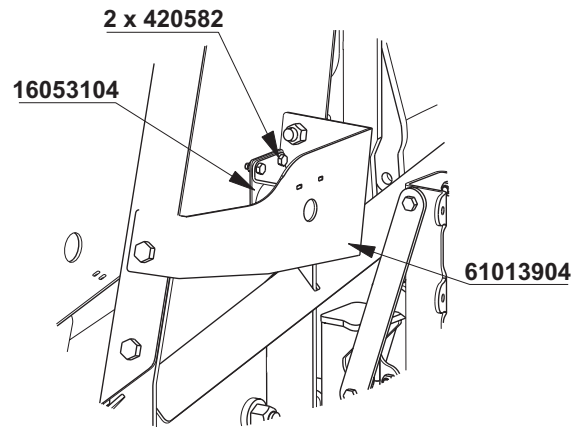

DETAIL: C
Granni Pot Vacuum Manifold Mount

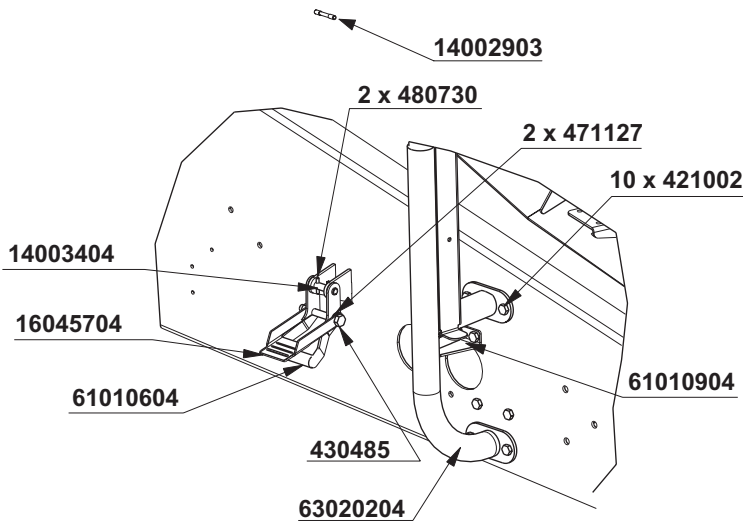

DETAIL: D
Flush Tank Tie-Down

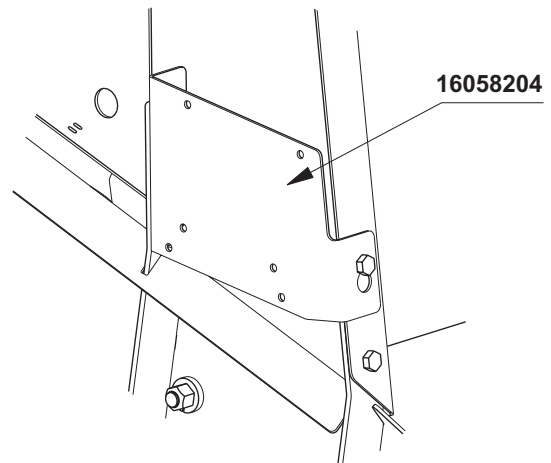

DETAIL: E
Foam Marker Compressor Mount

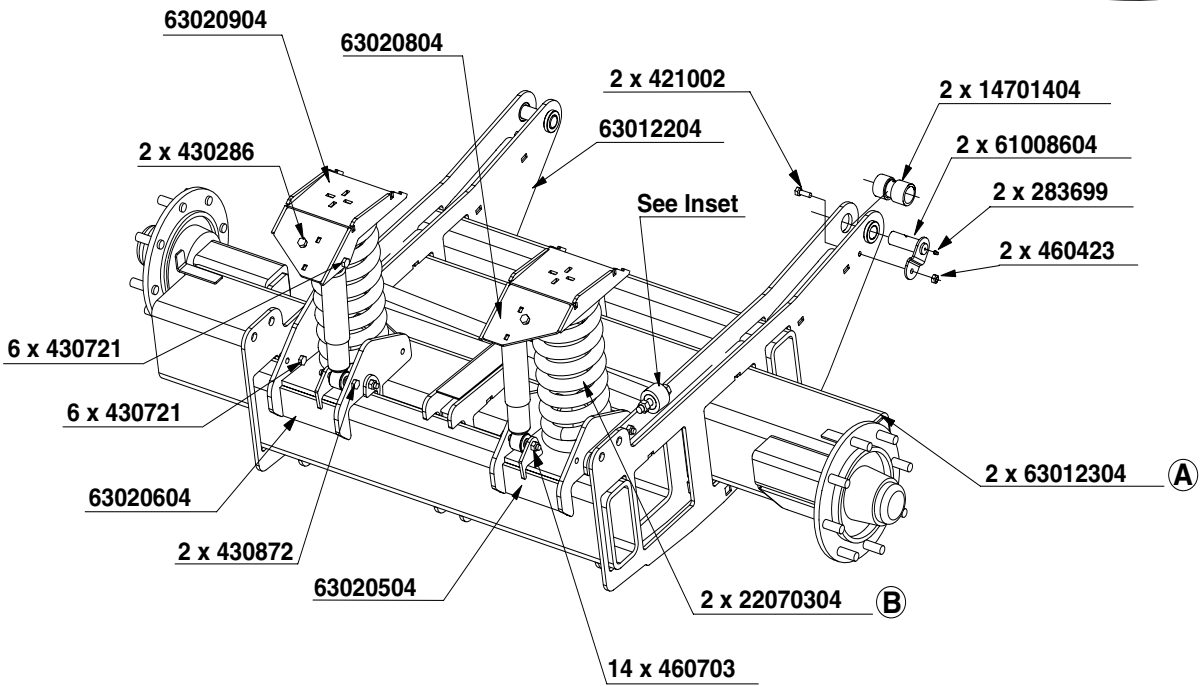
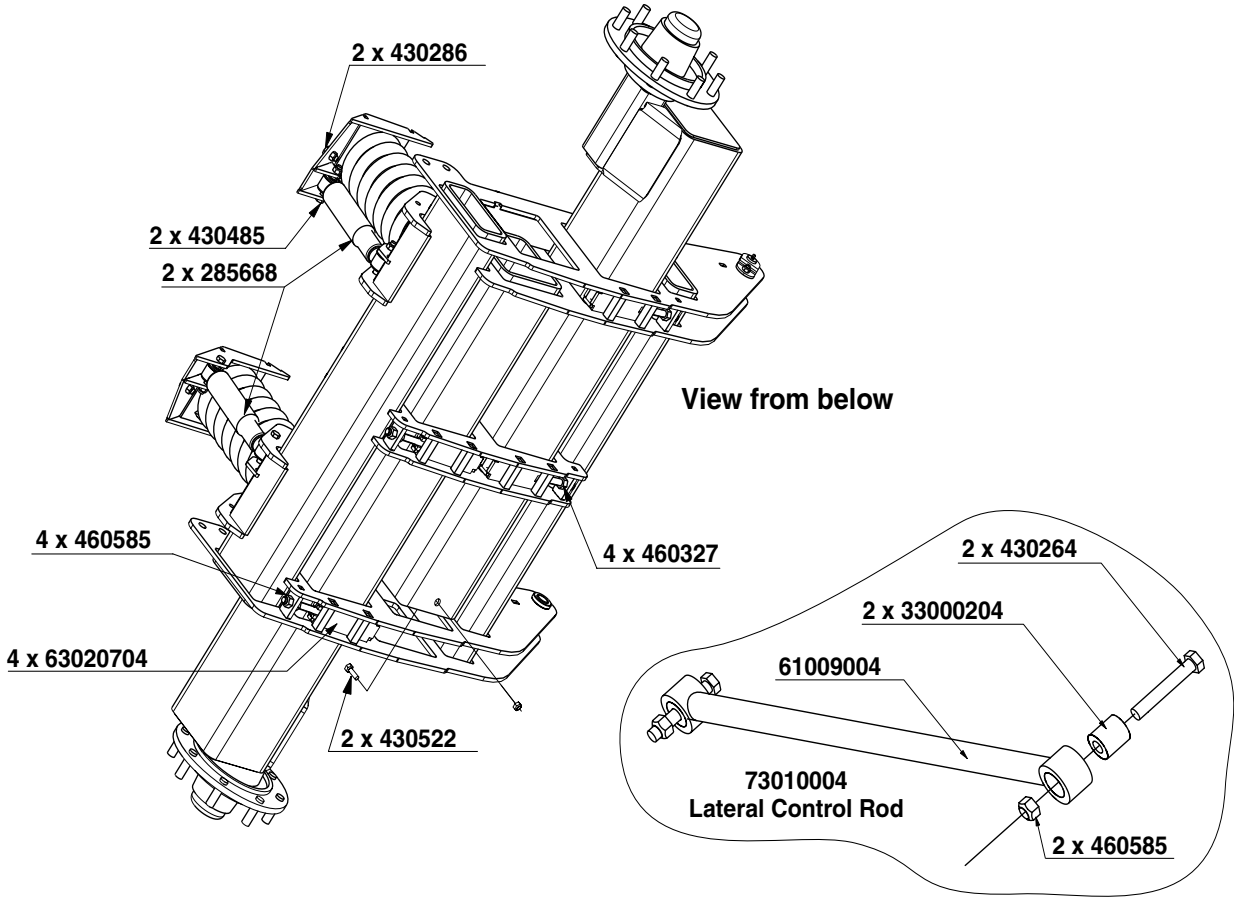

	A	B
83307804 - 5000L ADJUST SUSPENSION	63012304	22070304
83308104 - 4000L ADJUST SUSPENSION	63012404	22070404
8330xxxx - 3000L ADJUST SUSPENSION	63012404	XXXX

Drg 19

1.5 3m Adjustable Width / Suspension

HARDI NAVIGATOR

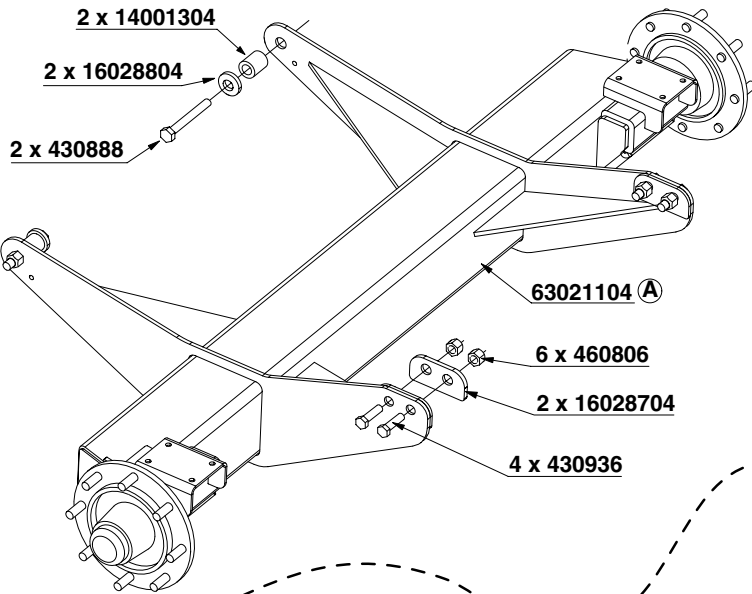

FIXED WIDTH AXLE NON-SUSPENDED 5000L

	A
5000L - 83308204	63021104
4000L - 83308304	63021004
3000L - 83308904	63022204

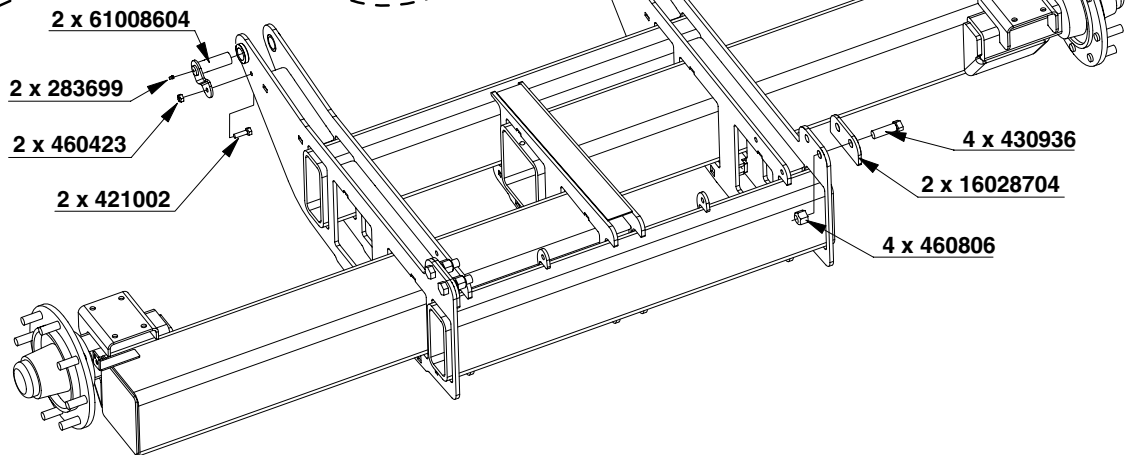

ADJUSTABLE WIDTH NON-SUSPENSION 5000L

	A	B
5000L - 83309204	63012304	63012204
4000L - 83309304	63012404	63012204
3000L - 83309404	63020104	63021304

View from below

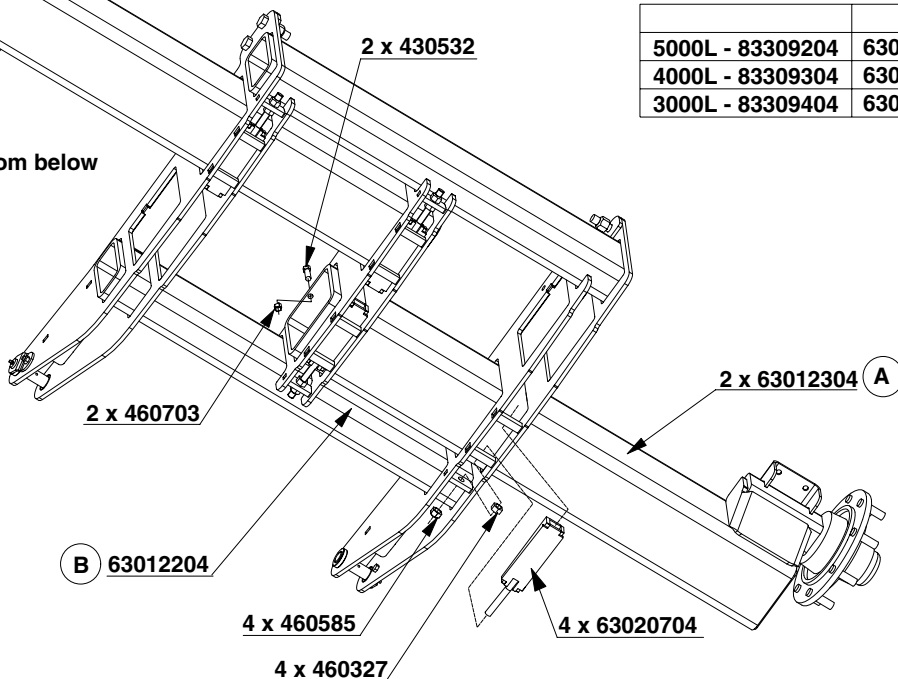

Drq 20
Non-Suspended Navigator

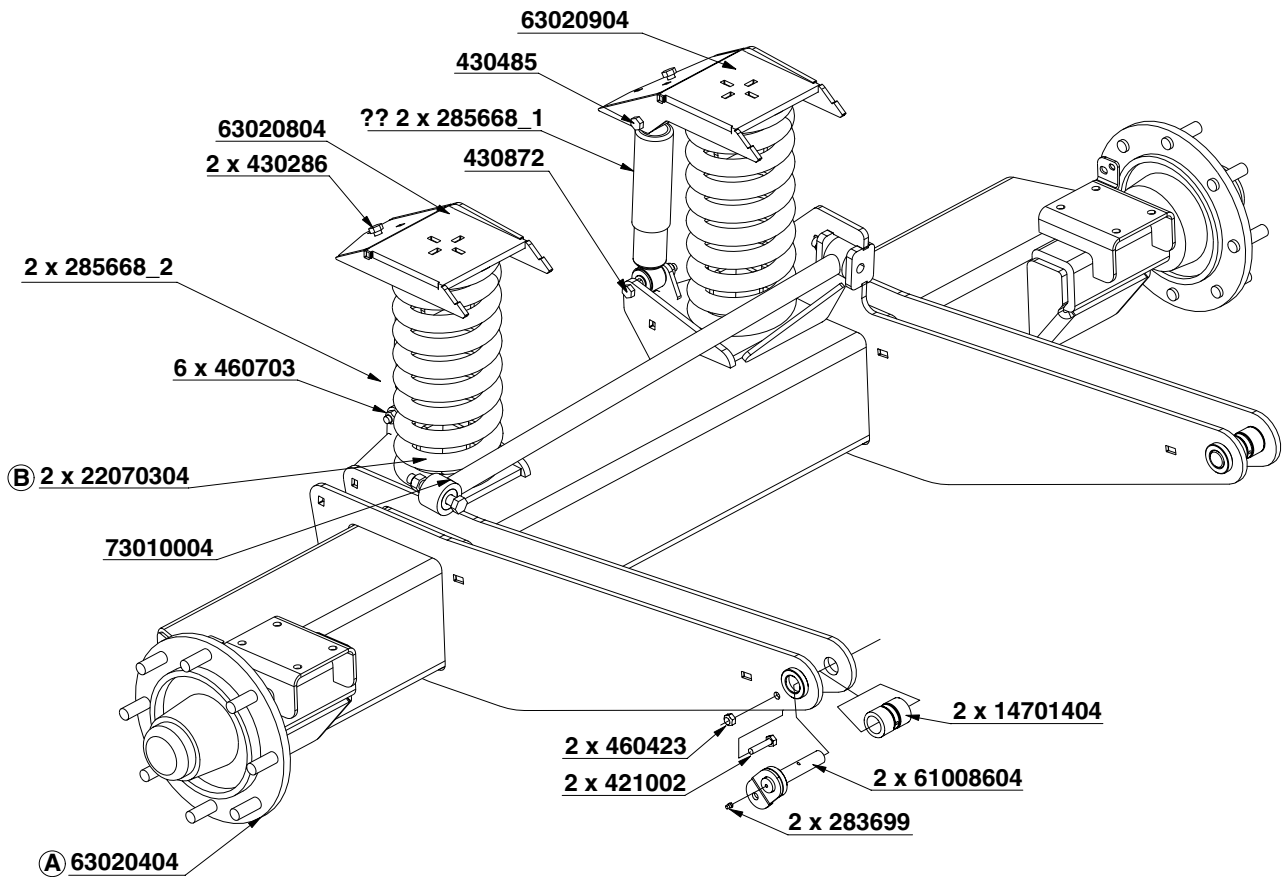

	A	B
83308004 - 2.2M SUSPENSION	63020404	22070304
83307904 - 2.2M SUSPENSION	63021104	22070404
83308804 - 2.2M SUSPENSION	63022204	22070504

Drq 21
2.2m Fixed Width Axle Suspended

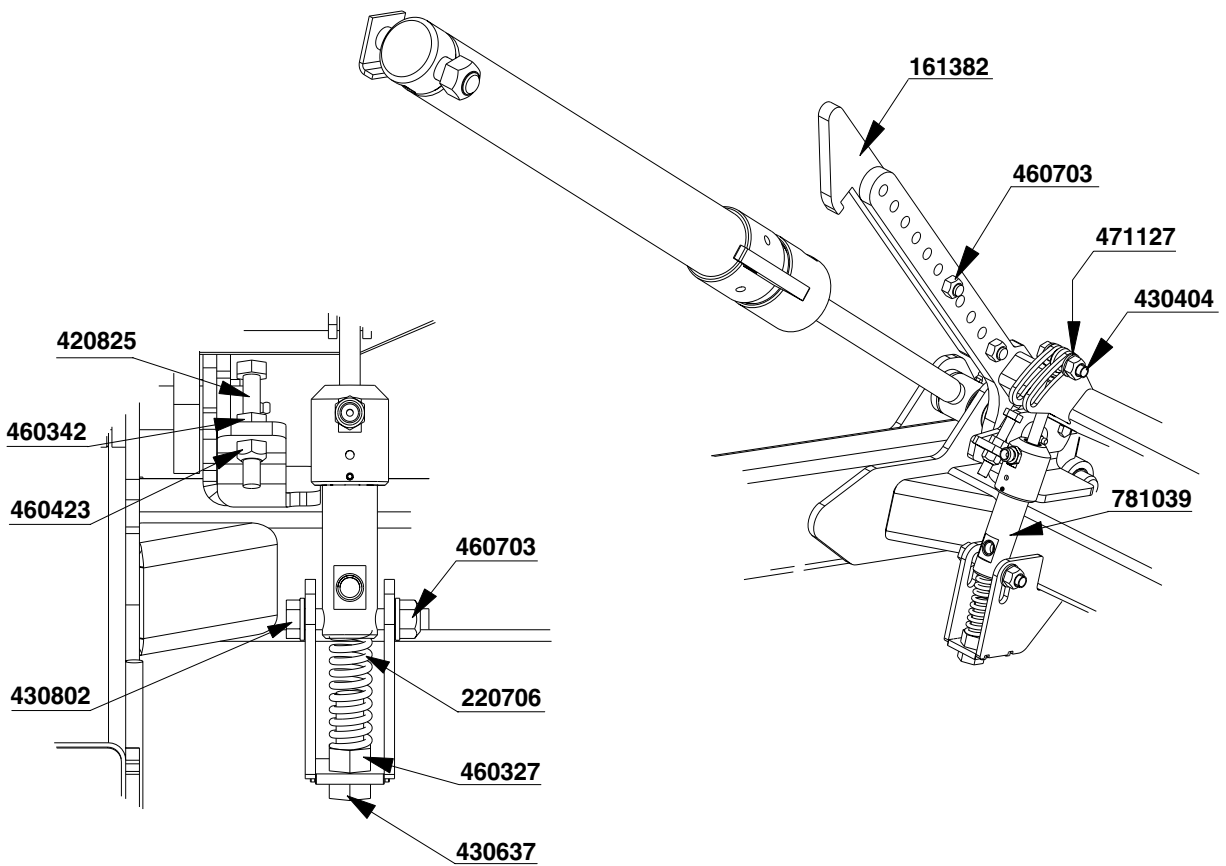
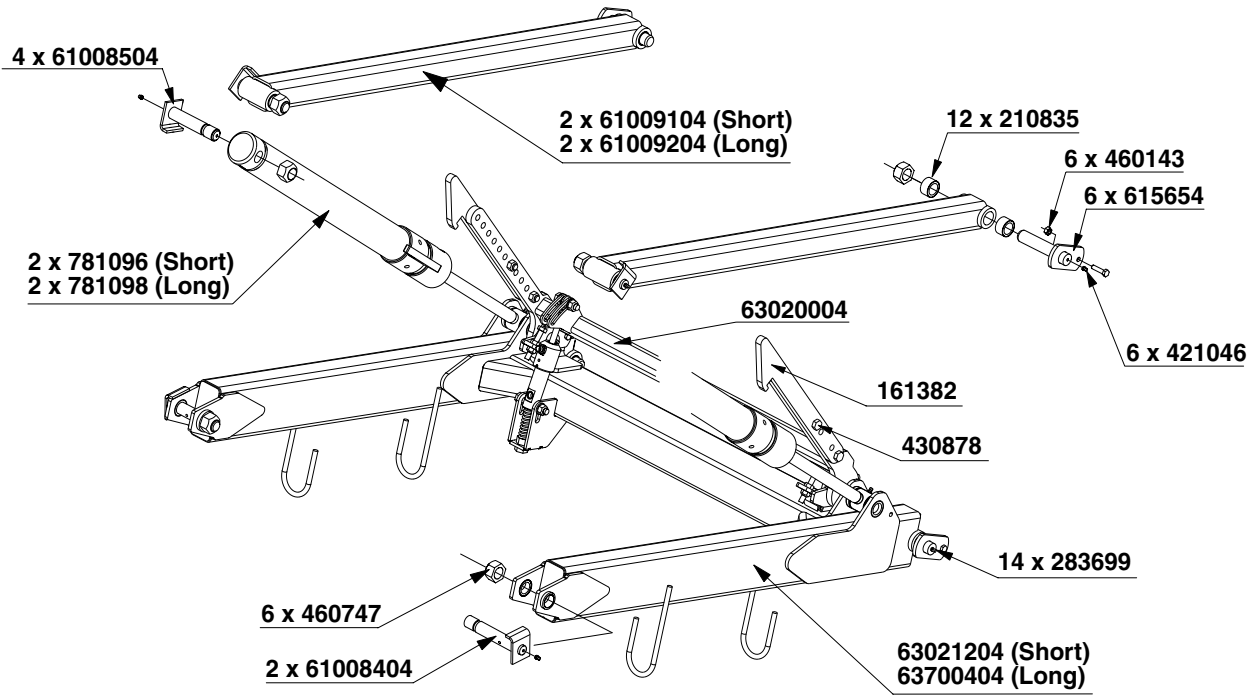

Drg 22
SHORT AND LONG PARALIFTS

NARROW CENTRE 18-20M - 83311204
WIDE CENTRE 24-30M - 83311004

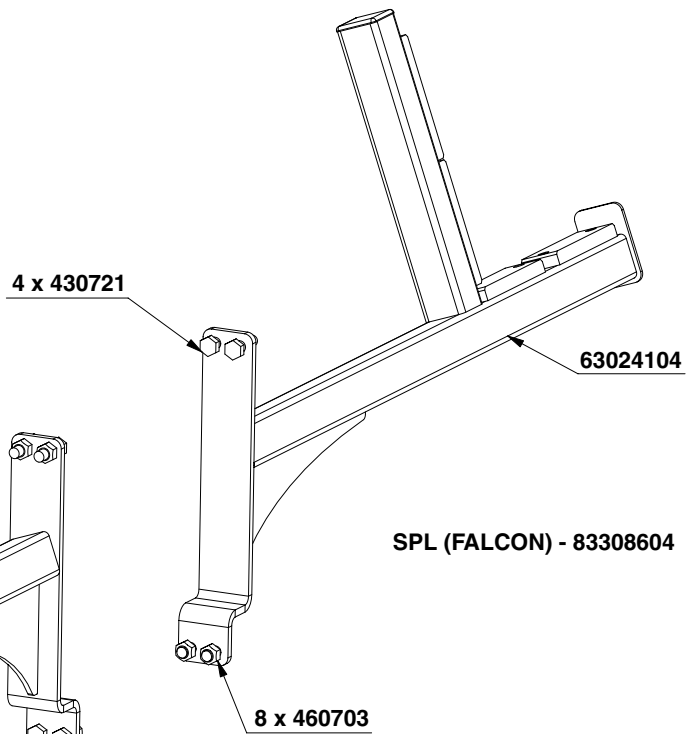
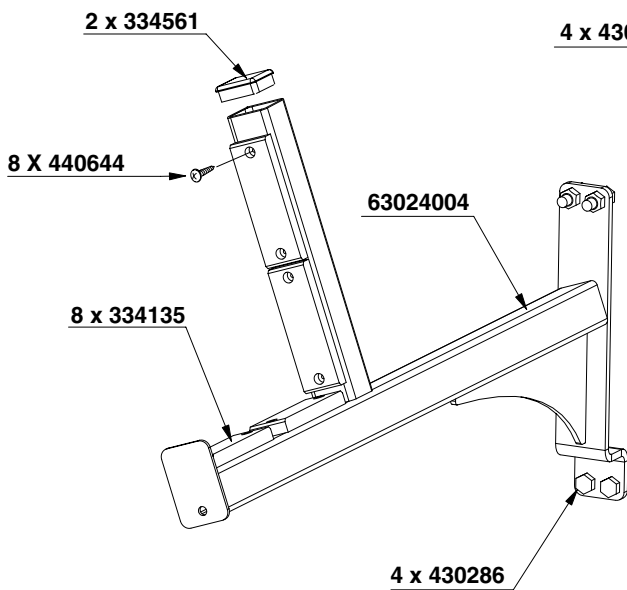
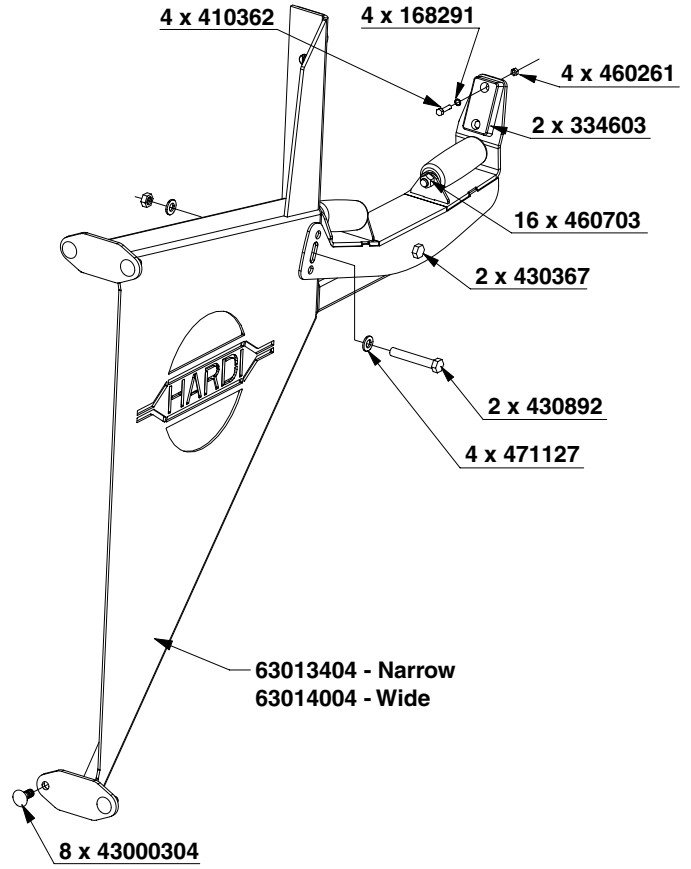
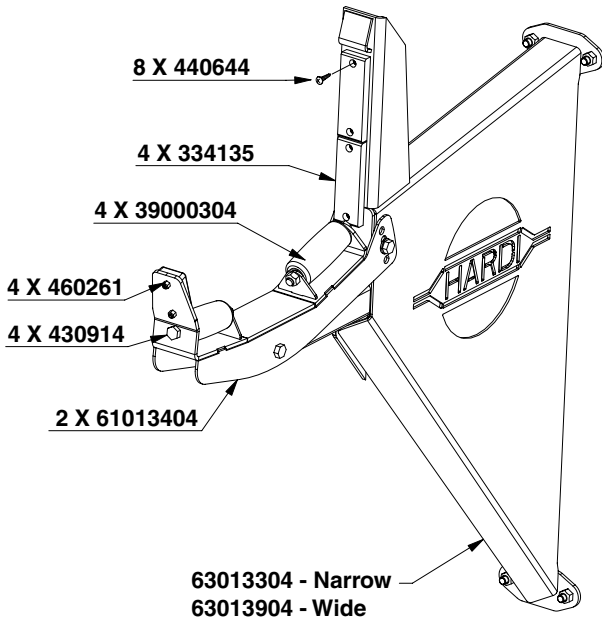

Drp 23
TRANSPORT BRACKETS

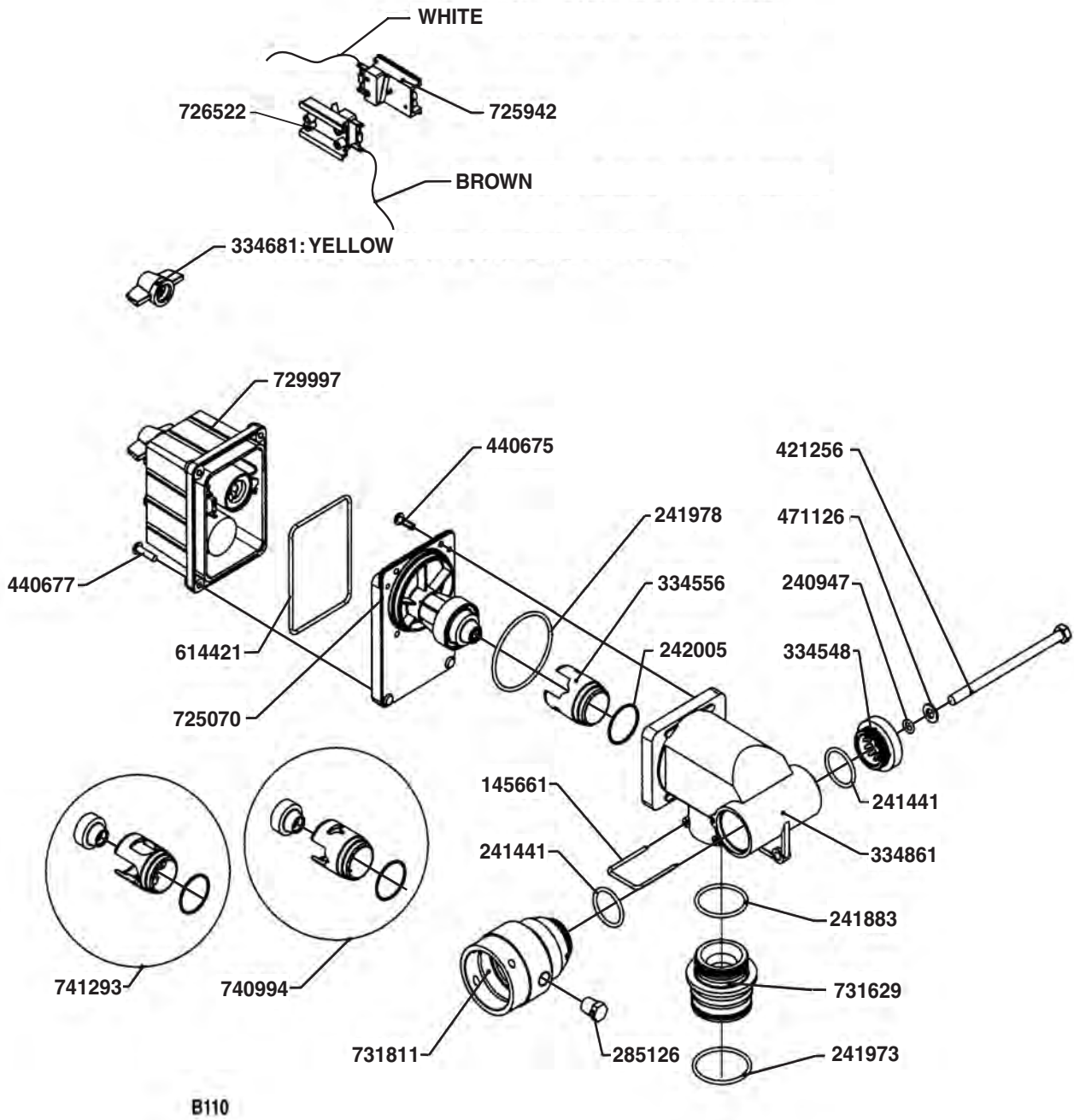

Drg 24
EVC PRESSURE REGULATOR UNIT

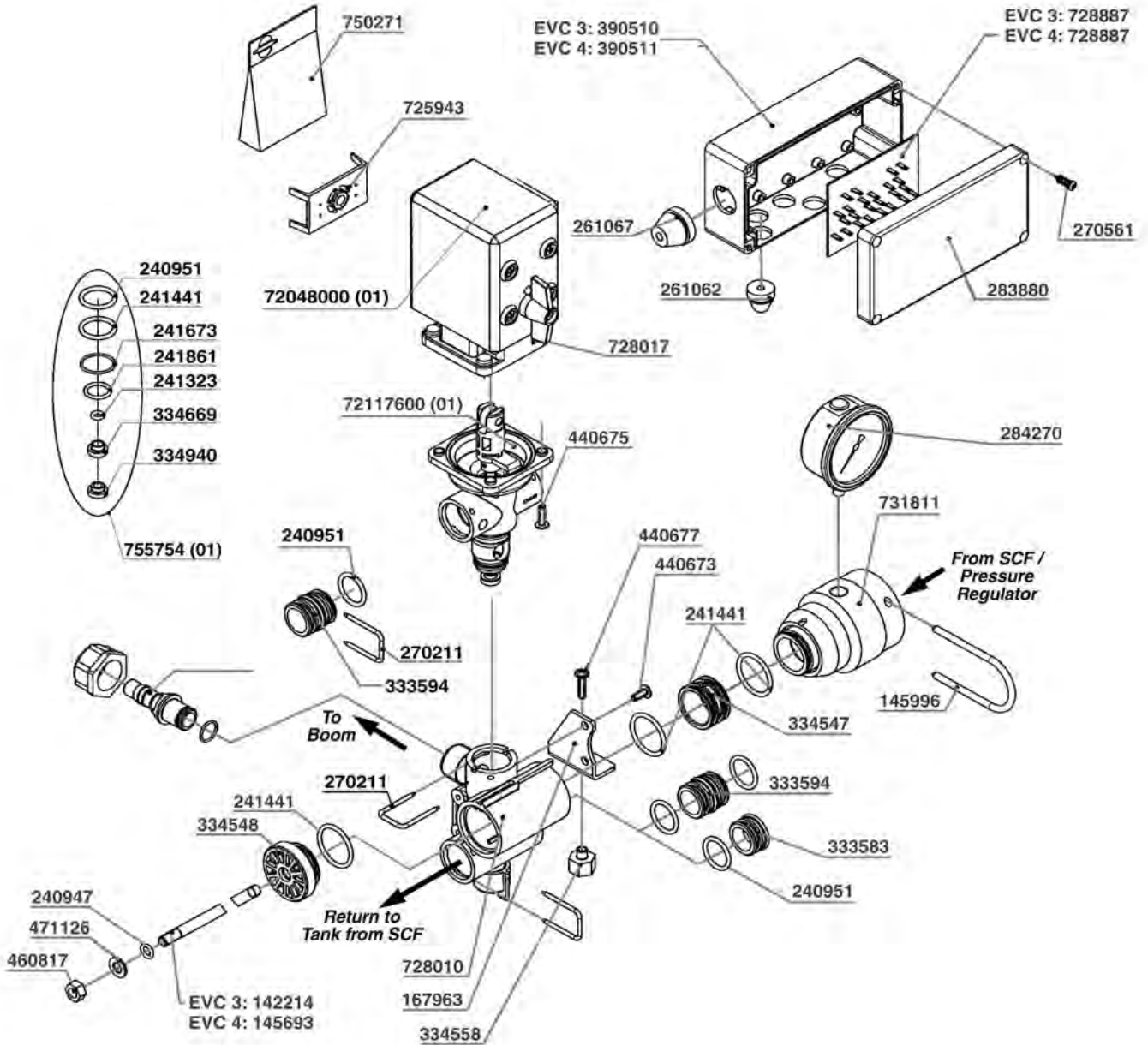



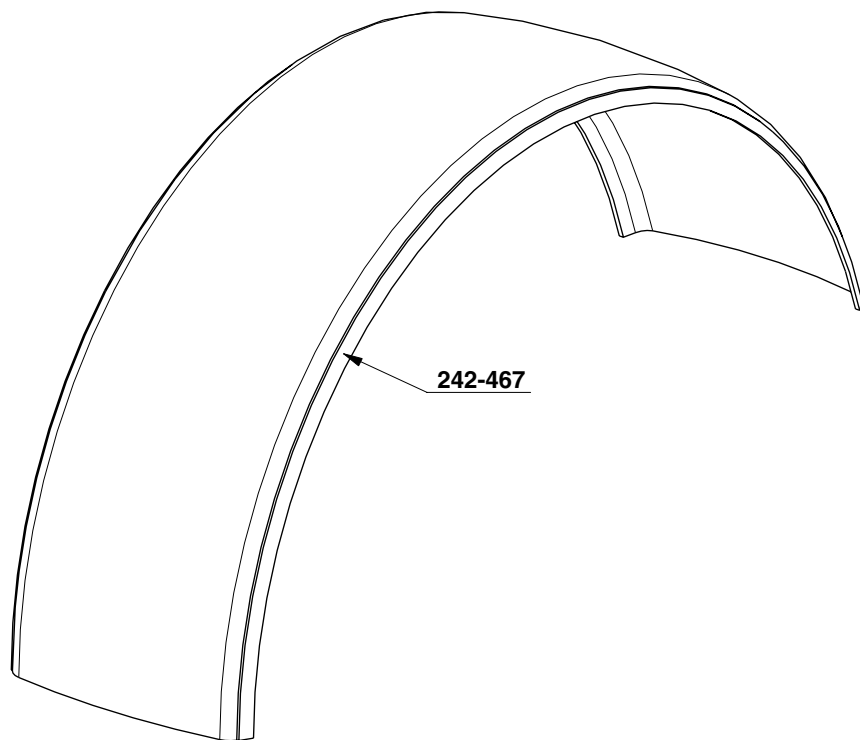
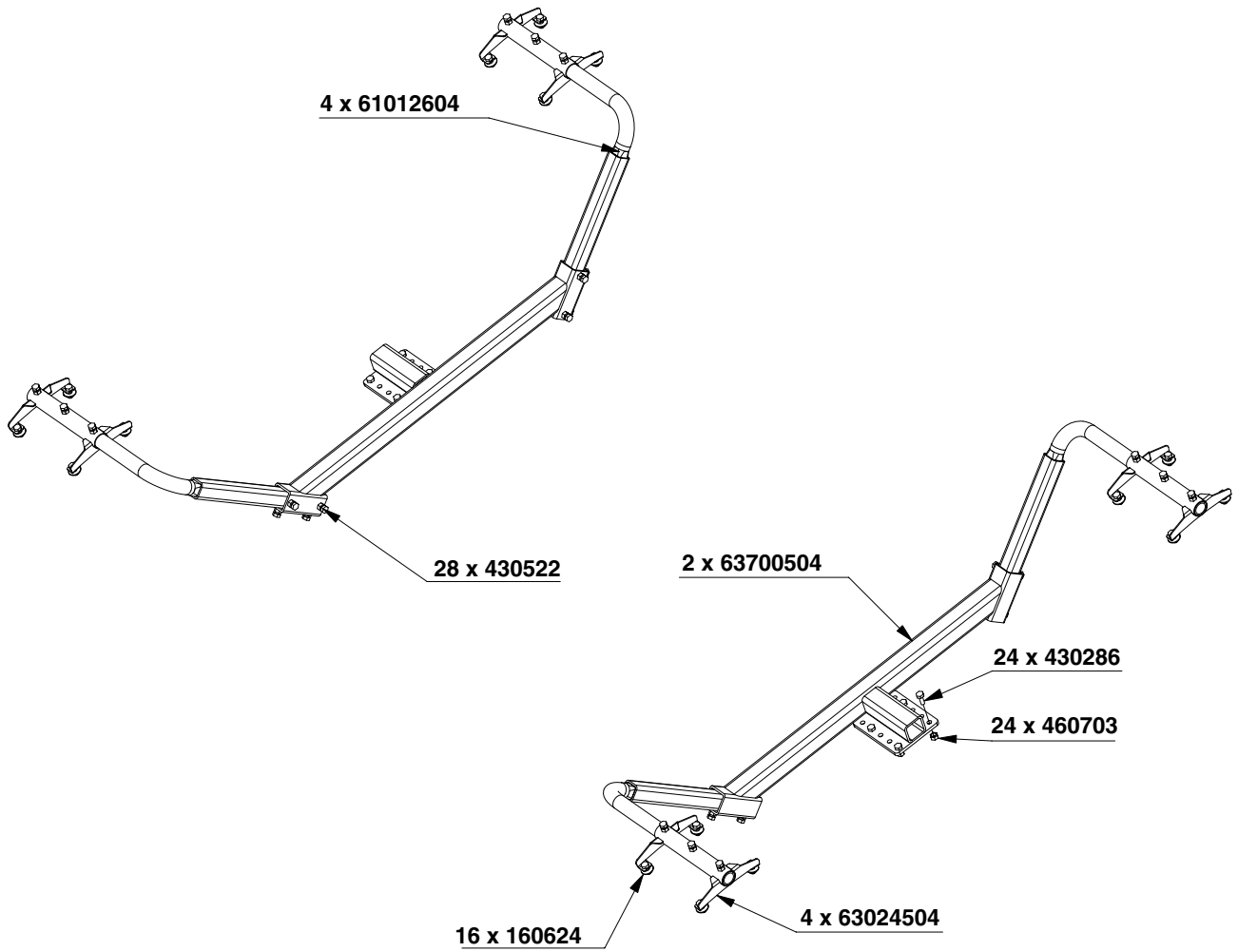

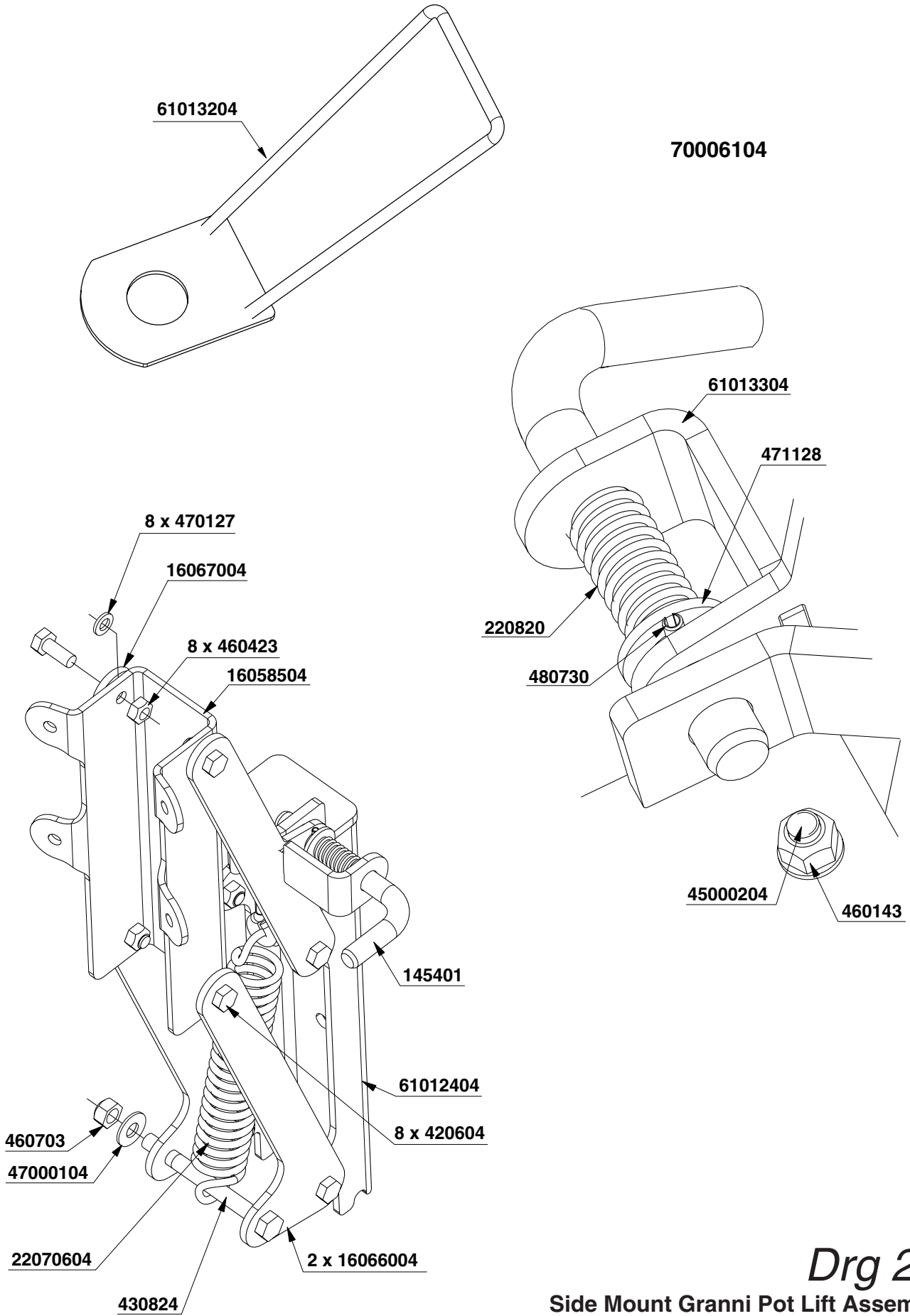

Drg 25
EVC DISTRIBUTION VALVE



Drg 26
Mudguards

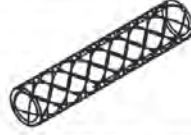
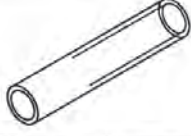

				
	RUBBER HOSE			
3/8" - 60 bar	927017	334533		1800mm (100m-927334)
12mm - 80 bar	927324	334533	284583	160m
1/2" - 60 bar	927021	334534		1800m
3/4" - 60 bar	927032	334531		1600m (100m - 927362)
1" - 60 bar	927124	334680	284585	800m (80m - 927363)
1 1/4" - 40 bar	927276		280265	40m
1 1/2" - 73 bar	927365		285722	40m
40mm - 35 bar	927194		280943	30m
50mm - 28 bar	927331		284724	30m
	PVC HOSE, BLACK, REINFORCED			
1/4"	927268		284582	500m
5/16"	927281		284582	500m
3/8"	927284		284583	150m
1/2"	927269		284583	100m
3/4"	927270		284584	150m
	PVC HOSE, CLEAR, REINFORCED			
1/2"	927265		284583	50m
3/4"	927231		284584	100m
1"	927280		283718	50m
	PVC HOSE, CLEAR			
12.5mm	927286	334533	284583	50m
3/4"	927205		284584	50m
	PVC SPIRAL SUCTION HOSE			
3/4"	927283		284584	50m
1"	927087		283718	50m
1 1/4"	927271		283810	50m
1 1/2"	927146		280265	50m
2"	927266		283810	50m

HARDI – ISO LD Series SYNTAL (Low Drift - 110 degrees)			
		Colour Tip	Single
S LD-01-110	Orange	755708 (12x371837)	755698 (12x371817)
S LD-015-110	Green	755709 (12x371838)	755699 (12x371818)
S LD-02-110	Yellow	755710 (12x371839)	755700 (12x371819)
S LD-03-110	Blue	755711 (12x371840)	755701 (12x371820)
S LD-04-110	Red	755712 (12x371841)	755702 (12x371821)



HARDI – ISO F Series SYNTAL (Flat – Optimum Coverage)			
		Colour Tip	Single
F-01-110	Orange	755627 (12x371764)	755643 (12x371706)
F-015-110	Green	755628 (12x371765)	755646 (12x371707)
F-02-110	Yellow	755629 (12x371766)	755649 (12x371708)
F-03-110	Blue	755630 (12x371767)	755652 (12x371709)
F-04-110	Red	755631 (12x371768)	755655 (12x371710)
F-05-110	Brown	755632 (12x371769)	755658 (12x371711)
F-06-011	Grey	755632 (12x371770)	755658 (12x371712)
F-08-110	White	755634 (12x371771)	755664 (12x371713)



HARDI – ISO INJET Series SYNTAL (Air Inclusion – Low Drift)			
		Single	B-JET (edge ½ spray)
S INJET-015	Green	755801 (6x371872)	
S INJET-02	Yellow	755802 (6x371873)	
S INJET-025	Lilac	755803 (6x371874)	755806 (2x371877)
S INJET-03	Blue	755804 (6x371875)	755799 (2x371878)
S INJET-04	Red	755805 (6x371876)	755800 (2x371879)



HARDI – 3 HOLE NOZZLE		
S 1003	Yellow	755718 (3x371537)
S 1003	Orange	755719 (3x371538)
S 1003	Red	755720 (3x371539)
S 1003	Green	755721 (3x371540)
S 1003	Blue	755722 (3x371541)
S 1003	Grey	755723 (3x371542)
S 1003	Black	755724 (3x371543)



HARDI Nozzles		Colour Tip
S4110-08	Violet	750325 (12x371469)
S4110-10	Brown	750326 (12x371470)
S4110-12	Yellow	730527 (12x371471)
S4110-14	Orange	735028 (12x371472)
S4110-16	Red	735029 (12x371473)
S4110-18	White	735030 (12x371474)
S4110-20	Green	735031 (12x371475)
S4110-24	Turquoise	735032 (12x371476)
S4110-30	Blue	735033 (12x371477)
S4110-36	Grey	735034 (12x371478)
S4110-44	Ivory	735035 (12x371479)



NOTE: The above table does not cover the entire range of Hardi Nozzles. For further information about the above nozzles, or for assistance with selecting from the complete list of available fittings, please contact your Hardi distributor.

CONTACTS

FOR HARDI SERVICE, SPARE PARTS and ADVICE:

Contact your Local Hardi Dealer / Service Centre - there are Local Hardi centres throughout Australia and New Zealand

Find your nearest dealer's details at www.hardi.com.au or by contacting Hardi Australia P/L at:

SOUTH AUSTRALIA OFFICE:

Phone: 08 8359 5400

Fax: 08 8260 3116

NEW SOUTH WALES OFFICE:

Phone: 02 9627 4555

Fax: 02 9627 5537

WESTERN AUSTRALIA OFFICE:

Phone: 08 9353 2088

Fax: 08 9353 5199

VICTORIAN OFFICE:

Phone: 03 9310 2211

Fax: 03 9310 2477

QUEENSLAND OFFICE:

Phone: 07 3375 3544

Fax: 07 3279 1292

NOTE: For supply of Spare Parts or replacement copies of Operators Manuals for Sprayer Units, Booms, Control Units, Pumps and Sprayer Accessories, you will need to provide details of the model and approx manufacture date to your local dealer .

EMERGENCY CONTACTS:

AMBULANCE:

FIRE:

POLICE:

LOCAL DOCTOR:

POISONS INFORMATION CENTRE:

PERSONAL CONTACT IN EMERGENCY:

OTHER IMPORTANT CONTACTS

LOCAL COUNCIL:

DEPARTMENT OF AGRICULTURE LOCAL BRANCH:

CHEMICAL SUPPLIER: