

The Sprayer Textbook

An explanation of components on broad-acre field sprayers
to help in the service and support of HARDI sprayers



HARDI | ACADEMY

Profit through knowledge



The Sprayer Textbook

By Anthony Facchin

Printed in Denmark

First published March 2016

Second edition January 2019

Third edition February 2020

Fourth edition February 2021

HARDI reference number 89278000

Herthadalvej 10, DK-4840 Nørre Alslev, Denmark

Text or illustrations in whole or in part may not be reproduced without the prior written permission of the author.

Subject to changes.

anthony.facchin@hardi.com

www.hardi.com

HARDI Academy, Denmark

Conversions

1.0 metre 39.37 inches

1.0 km 0.621 miles

1.0 litre 0.264 US gallons

1.0 hectare 2.471 ac

1.0 bar 14.5 psi

1.0 kilogram 2.205 pounds

1 litre/ha 0.107 US gallon/ac

1 Newton metre 0.74 lbft

20° Celsius 68° Fahrenheit

Celsius Fahrenheit (°C x 1.8) + 32

Note Left and right references are made in facing the direction of travel

The Sprayer Textbook

Contents

Dear Reader 9

PUMPS

Range and Identification 12

Stroke and revolutions 13

Crankshaft and transmission shaft 14

Diaphragms 15

Syntax of pump description. 16

Identification plate 17

Diaphragm pump advantages 18

Key identifying features 19

Lubrication 20

Connecting rod position for models 600, 320, 1200 and 1300 22

Changing valves and diaphragms. 24

Diaphragms and older pump models 25

Typical faults and remedies. 26

Transmission shaft. 28

Suction and pressure damper 29

CONTROLS

Control types overview 32

HARDI-MATIC pressure regulation valve volumetric control. 34

Principles of pressure equalisation 35

Pressure gauges. 36

Basic sprayer functions 37

BK controls 38

EVC controls. 39

EFC controls. 40

DynamicFluid4 regulation system. 41

DynamicFluid 4 42

FILTERS AND NON-RETURN VALVES

Filtration. 44

Filter colour-coding and mesh 45

Filter choice 46

Suction filters – top mounted 47

Suction filters – bottom mounted. 48

Pressure filters. 49

Self-cleaning filter and CycloneFilter 50

Non-return valves 51

FASTFILLER, SAFETY AND SMARTVALVES

FastFiller and Ejector	53
Safety valve	54
Manifold and SmartValves	55

FUNCTION DIAGRAM FOR LIQUID SYSTEM

Functions overview.	57
-----------------------------	----

NOZZLES

Understanding the application task	59
Four basic nozzle types.	60
Tapered FLAT FAN nozzle distribution	61
Range of HARDI ISO nozzles	62
Nozzle offset angle.	63
Nozzle to target distance	64
Droplet volume, diameter and coverage.	65
Drift reducing nozzles	67
Fertiliser nozzles	68
Nozzles for orchard sprayers and mistblowers.	69
Specialised nozzles	70
Nozzle materials and wear rate	71
Calibration	72
Calibration disk	72
Calibration online	73

HYDRAULICS

Symbols	76
Cylinders and seals for hydraulic fittings	77
Open and closed centre tractor hydraulics	78
HARDI “Y” hydraulic function	79
HARDI “Z” hydraulic function	79
Tractor oil supply.	80
HARDI Y hydraulics.	81
Z hydraulics; By-pass block	82
Direct Acting Hydraulics	83
Indirect Acting Hydraulics	83
Direct Hydraulics.	84
HARDI TWIN STREAM Hydraulics	85
HARDI TWIN FORCE Hydraulics.	86

BOOMS

The task	89
Boom suspensions	90
The A trapeze	91
The Pendulum	91
Boom abbreviation codes and names	93
Air-assisted booms	95
Alternative boom types	97
Terminology of boom parts and movements	98
Terminology of boom controls	99

TANKS & FRAMES

General principles of tank design	102
Drain valves	103
The Frames	104
The Drawbars	105
Frame suspension systems	106
Tracking systems	107
Tracking systems	108

BLOWER UNITS

Vine and orchard sprayers or mistblowers	110
Air volume and driving speed	111
Axial blowers	112
Centrifugal blowers	113

SPECIAL EQUIPMENT

Operator safety and WorkZone concept	116
Transfer equipment	117
ChemFiller and TurboFiller	118
TurboFiller	119

FITTINGS

O-rings and gaskets	122
Hoses and clamps	123
S-fittings for tanks and components	124
HARDI boom tubing systems	125

ELECTRICAL EQUIPMENT

HARDI spray computers	128
HARDI sprayer computers	129
HARDI sprayer computers	130
Monitor and Controller basics	131
Speed sensors.	132
Flow sensor	133
Computer menu tree	134

FAULT-FINDING

Basic Tools	136
The Toolbox	137

IDENTIFICATION

Parts numbers logic	140
Parts number version identification	141
HARDI Parts Catalogue.	142
Symbols.	143
Lift mounted.	144
Trailed	151
Demount	160

ABBREVIATIONS

Abbreviations A-Z	164
-----------------------------	-----



Foreword

Dear Reader

Most people are fascinated by modern agricultural sprayers. The huge size and automation of nearly everything is truly remarkable and almost incredible if we go self-steering, self-propelled sprayers.

Strangely enough, the basic composition of a sprayer has not changed much over the last 60 years. It still comprises of a pump, controls, tank, frame, filtration and nozzles. The components have been refined but not the composition.

You are probably about to read this book because you are involved with service and support for the HARDI customer. This book is written to give you a basic understanding of the HARDI sprayers. It is divided into chapters that will guide you through the sprayer, component by component that, in the end, will help you understand the complete sprayer.

The chapters follow the divisions of the HARDI parts catalogue and start with pumps as the pump is the “heart” of the sprayer. This textbook also includes nozzle basics as the nozzle is the deciding component, the “brain” if you like, for spray quality before the liquid leaves the sprayer.

The chapters may also contain some historical content as an aid to help you understand the present products.

A chapter on the principles of fault-finding technique is also included. This will hopefully minimise your on-farm time and maximise the customer satisfaction.

The final chapter addresses identification of the HARDI sprayers. It includes part number logic, symbols and identification of older models. The model identification might be of help in finding the correct parts for these older models.

This book mainly addresses broad-acre field sprayers although vineyard and orchard sprayers are mentioned.

It is also used as background material for the HARDI basic training courses and in conjunction with a slide series used on these courses.

The HARDI world started in 1957. We make sprayers from the ground up and know nothing else but sprayers and spraying. This makes us both sprayer specialists and the best ally a customer can have and vulnerable should we not live up to customer expectations. It forces us to be pioneers in the world of agricultural application techniques and machinery and we enjoy this challenge.

We hope you also enjoy the challenge and welcome you to our HARDI world.

About the author

Anthony Facchin was born in 1956 in Horsham, a country town in the middle of an Australian farming community. After completing studies in agriculture, Anthony Facchin worked on Australian, Canadian and Danish farms and then settled into an Australian business supplying agricultural pesticides and spray equipment. With a flair for technique, he started a 2-year apprenticeship with HARDI in Denmark, and after this he returned to Australia to work for a HARDI importer.

In 1985, Anthony returned to HARDI in Denmark where he worked in Technical Service, Product Management, Export and After Market. In 2010, Anthony was appointed manager for HARDI Academy in Denmark for the Global Marketing Group.





CHAPTER 1

PUMPS

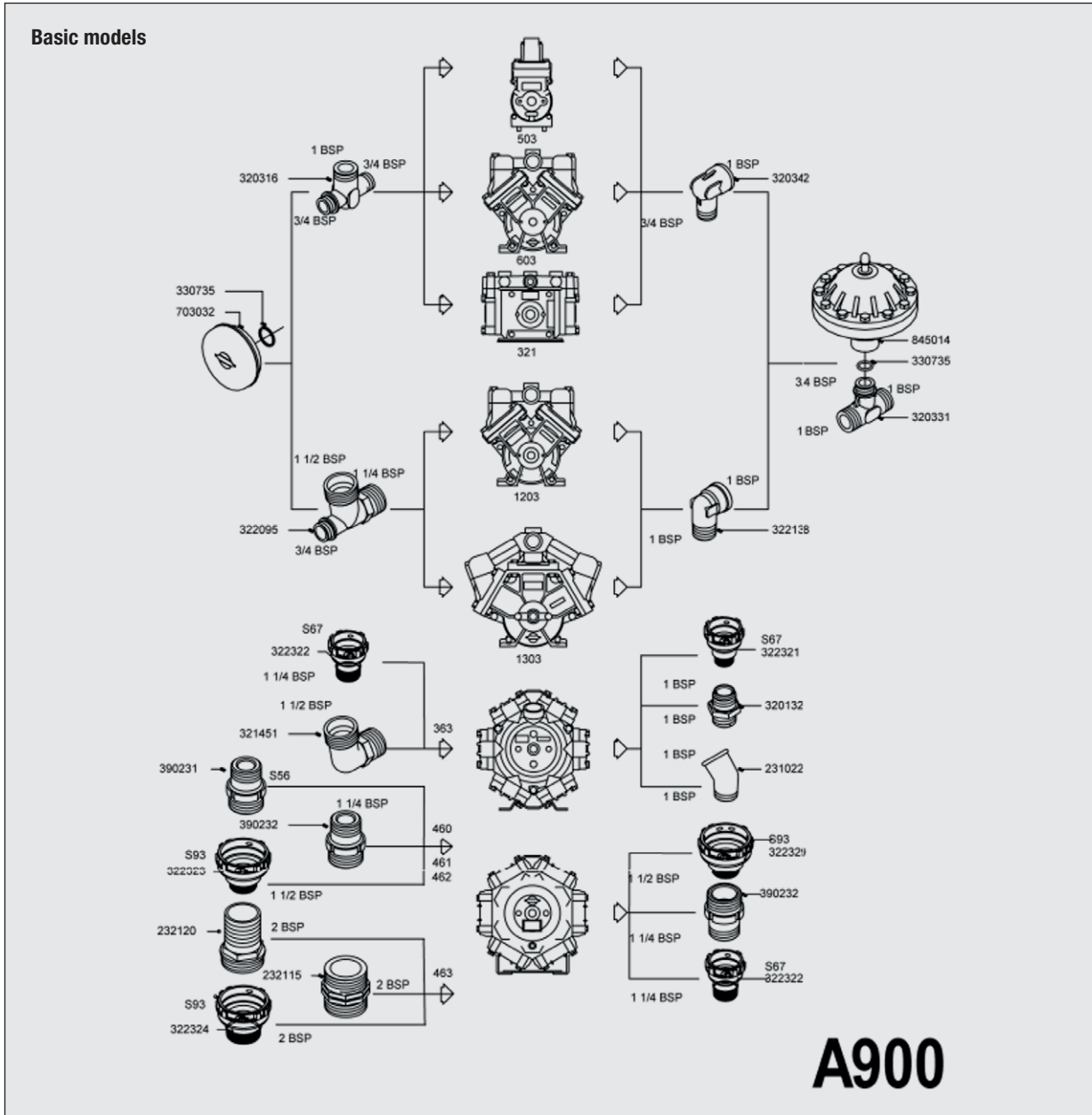

Range and Identification

The HARDI company is founded on the diaphragm pump and started the business in 1957. The concept of a simple, robust pump with dry sump and cast iron crankcase and covers has not changed. There are now 7 basic models. The above diagram is from the A900 pages of the HARDI Parts Catalogue.

Model base names are 500, 600, 320, 1200, 1300, 360 and 460.

With updates, the last digit has changed, e.g. model 500 is now called model 503.

The pumps only have 1, 2, 3, or 6 diaphragms:

- ▶ 1 for 500-503 model pumps
- ▶ 2 for 600-603, 320-321 and 1200-1203 model pumps.
- ▶ 3 for 1300-1303 model pumps.
- ▶ 6 for 361-364 and 460-464 model pumps.

The older series of pumps, models 500, 600, 1200, 1202, 1300, 1301 and 1302 have imperial thread. The newer series of pumps which include 503, 603, 1203 and 1303 are metric. They are recognized in the naming of the pump ending with "03". The liquid connections are always British Standard Pipe (BSP) inch thread. The pump capacity between old and new has not changed but all parts related to the thread and bolt sizes will have new reference numbers.

Model variants

E.g. Model 503:

- Stroke
- Revolutions
- Crankshaft type
- Diaphragm (material)

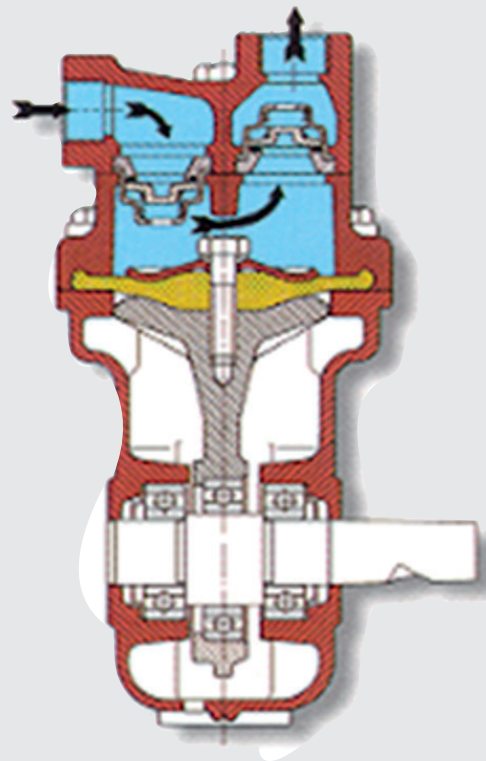
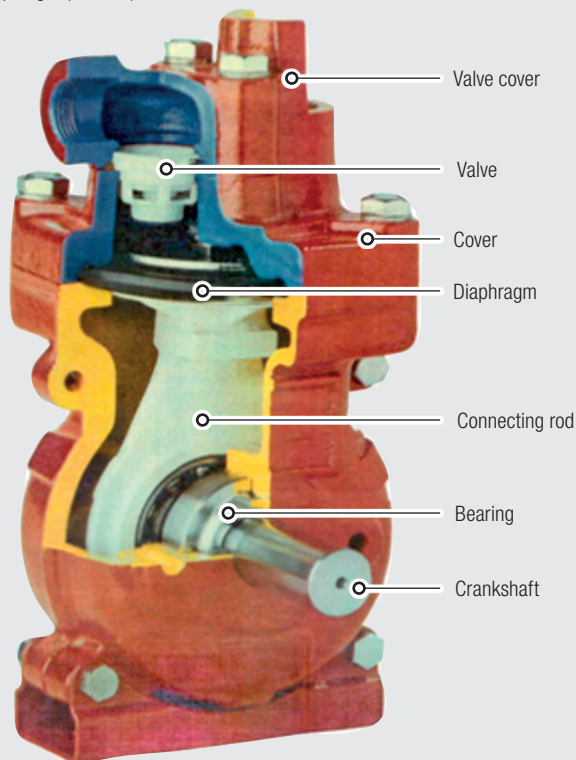

Stroke and revolutions

Models have different versions e.g.:

- Crankshaft type
- Diaphragm (material)

Stroke

Usually stroke is stamped on the crankshaft. Pumps with 3, 4, 5 or 6 mm strokes are typically for 1000 r/min applications. Pumps with 7, 9, 10 or 12 mm strokes are typically for 540 r/min applications.

Revolutions

The rule is the higher the r/min, the shorter the stroke. This maintains the same capacity but reduces mechanical damage to the diaphragms. Conical shafts are usually on 540 r/min pumps. Note that it is not necessary to operate the pump at 540 r/min if the full pump capacity is not required for the particular task.

Pumps with 6 spline crankshafts are for 540 r/min and those with 21 splines are for 1000 r/min.

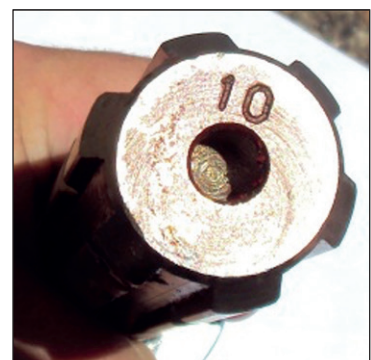

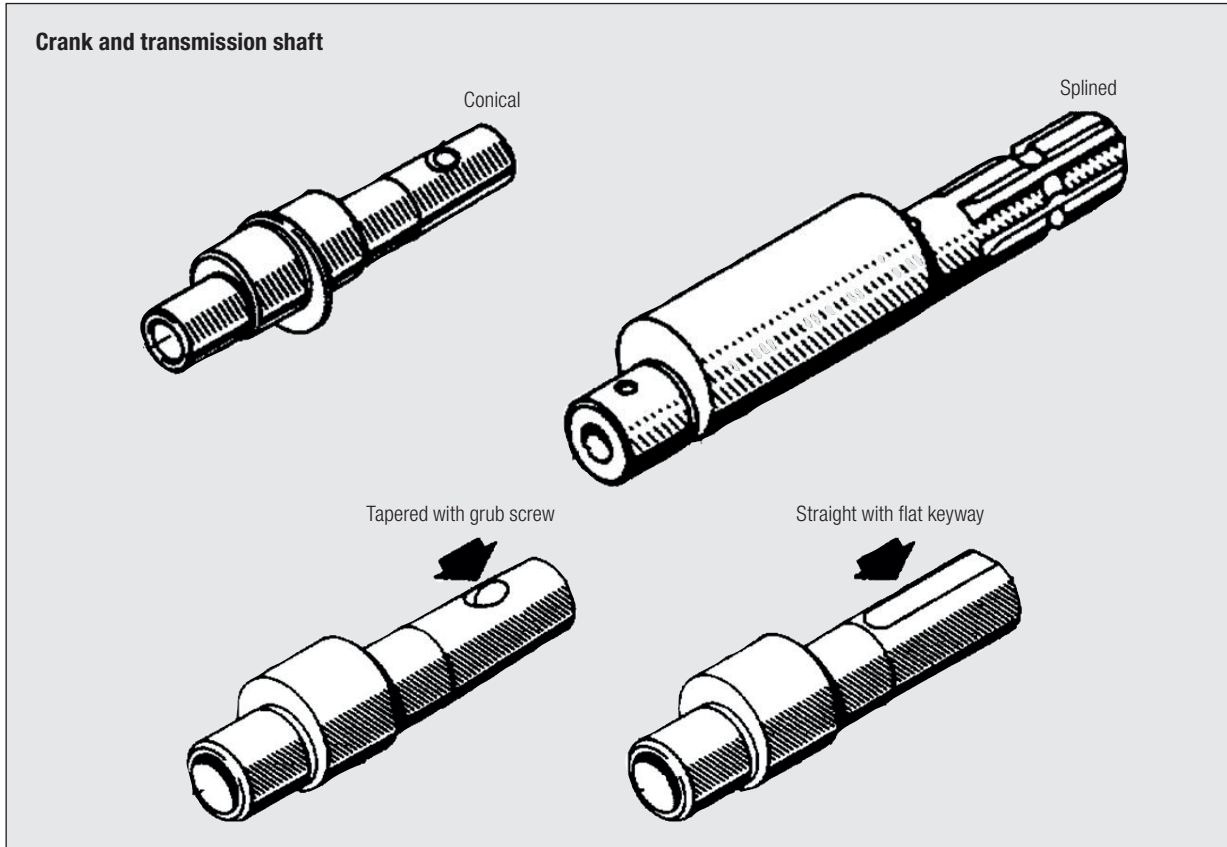

Crankshaft and transmission shaft

Crankshaft type

Conical, splined and straight shafts are used:

- ▶ Conical (or tapered) shafts are used on the 1, 2 and 3 diaphragm pumps.
- ▶ Splined shafts are on the 6 diaphragm pumps and on some Model 321 pumps.
- ▶ Cylindrical (straight) shafts are used on the 1, 2 and 3 diaphragm pumps which are usually powered by a stationary electrical or combustion engine.

Some pumps have through-going crankshafts to power auxiliary equipment like a hydraulic pump.

Tractor power take-off (PTO)

The PTO usually supplies the mechanical power to the sprayer and is connected to the sprayer with a transmission shaft. The spline type may vary. The standard 540 r/min shaft has 6 splines and is 13/8" in diameter. Newer types for higher revolutions and power applications are found on larger tractors. A 21 spline 13/8" diameter transmission shaft is also available. Some Soviet and Chinese tractors have 8 splined shafts that rotate at 540 or 720 r/min.

Splined HARDI transmission shafts are available in 6 or 8 spline for 540 PTO r/min and 21 spline 1000 PTO r/min. If a PTO drive is not available or desired, the pump can be hydraulically driven.



Diaphragms

Diaphragm and O-ring material

Historically many materials were available for diaphragms. Today, there are basically 2 versions, polyurethane (PUR) or Nitrile.

O-rings requiring a high resistance to pesticides are supplied in a material called Viton.

Material	Usage	Colour	Advantage	Disadvantage
Polyurethane	Standard for diaphragms Some O-rings	Yellow	Good all round value Low cost	Poor UV resistance
Nitrile	Option for diaphragms Some O-rings	Black	Good mechanical resistance Good heat resistance Low cost	Poor chemical resistance with alkaline and petro-chemical liquid
Viton® (Registered trade name of DuPont)	O-rings	Green, brown matt black	High chemical resistance	Low mechanical resistance High cost

Identification plate of a Model 464 pump



Identification

- 1 Model / mm stroke
- 2 Max. operation revolutions
- 3 Identification number
- 4 Capacity
- 5 Max. pressure

Identification plate

An identification plate on the pump, usually at the front or rear, shows:

- ▶ Model / mm stroke
- ▶ Max. working revolutions
- ▶ Identification number. *See below on ID*
- ▶ Pump capacity. *Note the capacity drops a little at higher pressure*
- ▶ Max. pressure. *Some HARDI diaphragm pumps go to 20 or 25 bar*

The table indicates the capacity output ranges for the various models.

The identification number (ID)

- ▶ First 2 digits are the production year
- ▶ Next digits are order number
- ▶ Last digits are serial number

The power usage is relatively low.

Pump life can be extended by operating at lower pressures and lower revolutions, using the correct grease and cleaning it after the spray job.

Model	Capacity range (l/min)	Capacity range (US gpm)
503	14 to 16	3.6 to 4.2
603	26 to 31	6.8 to 8.2
321	48 to 73	12 to 19
1203	99 to 108	26 to 28
1303	114 to 136	30 to 36
364	140 to 194	37 to 51
464	280 to 349	74 to 92

Types of pumps used in agriculture

Pump type	Advantage	Disadvantage
Piston	High pressure (80 bar +). Proportional output	High wear rate. Must not run dry
Centrifugal	High capacity	Capacity drops (< 10 bar) Cannot prime Output not proportional
Roller vane Gear	Compact	High wear rate Must not run dry Low capacity
Diaphragm, oil filled	High pressure (40 to 60 bar) Proportional	Difficult to service Oil pesticide mix
Diaphragm, dry	Long life Proportional Easy to service	Max. pressure 20 bar

Diaphragm pump advantages

The diaphragm pump is the founding component of the company. The advantages to the user gave benefits no other pumps could offer:

- ▶ Self-priming (can suck liquid when filling)
- ▶ Able to run dry (no damage)
- ▶ Easy to service (user can do this)
- ▶ Grease lubricated (dry sump, drained housing)
- ▶ Rotates clockwise or anti-clockwise (no damage)
- ▶ Chemical resistant valves and diaphragms

The HARDI pumps are robust, easy to service and simple with crankcases and covers made of cast.

The crankcase has a drain hole at the bottom. When spray liquid leaks from this drain, the diaphragm needs to be changed. If the pump was oil lubricated, i.e. wet sump, the oil will contaminate the spray liquid and the spray liquid will probably damage the pump bearings.

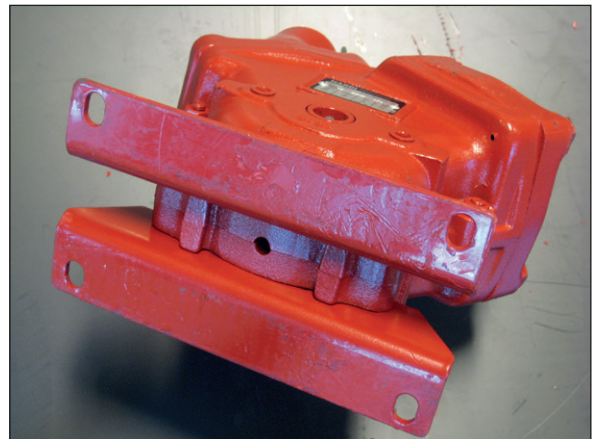

Key identifying features



500 - 503

Model 500 series (500, 503)

- ▶ One diaphragm
- ▶ Conical or straight shaft
- ▶ ¾" inlet and outlet

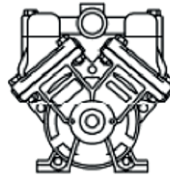

1200 - 1203

Model 1200 series (1200, 1202, 1203)

- ▶ Two diaphragms with V-configuration
- ▶ Conical or straight shaft
- ▶ Cast iron feet
- ▶ Height: 320 mm
- ▶ 1200: ¾" inlet and outlet
- ▶ 1202 and 1203: 1¼" inlet and 1" outlet



600 - 603

Model 600 series (600, 603)

- ▶ Two diaphragms with V configuration
- ▶ Conical or straight shaft
- ▶ Detachable feet
- ▶ Height: 263 mm
- ▶ ¾" inlet and outlet

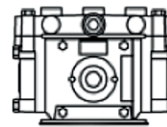

320- 321

Model 320 series (320, 321)

- ▶ Two diaphragms with Boxer (opposed) configuration
- ▶ ¾" inlet and outlet



1300 - 1303

Model 1300 series (1300, 1301, 1302, 1303)

- ▶ Three diaphragms
- ▶ 1300: ¾" inlet and outlet. 1301, 1302 and 1303: 1¼" inlet and 1" outlet
- ▶ 1302 and 1303: Have ribbed, synthetic connection tubes in valve chambers



360 - 364

Model 360 series (360, 361, 363, 364)

- ▶ Six diaphragms
- ▶ Length: 222 mm
- ▶ 361 and some 363: 1¼" inlet and 1" outlet
- ▶ 363: 1½" inlet and 1" outlet
- ▶ 364: Black covers over top 4 valve covers, 2 grease nipples under pump
- ▶ 6 spline is for 540 r/min and 21 spline is for 1000 r/min

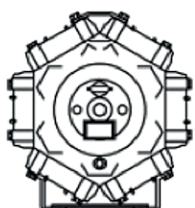

460 - 464

Model 460 series (460, 461, 462, 463, 464)

- ▶ Six diaphragms, introduced early 1998
- ▶ Length: 264 mm
- ▶ 460: 1½" inlet and 1¼" outlet; 462: 1½" and 2" inlet and 1¼" outlet
- ▶ 463: 2" inlet and 1¼" outlet; Valve covers with boss for connecting rod bolt
- ▶ 464: Black covers over top 4 valve covers, 2 grease nipples under pump
- ▶ 6 spline is for 540 r/min & 21 spline is for 1000 r/min

Lubrication points

A - 50h

A - 50h

A-50 **30g** **A-50** **30g**

10 x = 10 gram

30 x = 30 gram

Lubrication

The HARDI pumps require greasing every 50 hours of work. Most pumps have just one central grease point found on the crankshaft. There are 3 exceptions:

- ▶ **Model 1300 pumps:** There are 3 grease points; one on the shaft and one on each side of the pump near the centre of the crankcase.
- ▶ **Model 464 and 364 pumps:** There are 2 grease points at the bottom of the pump.

Some of the older pumps with a through-going shaft require removal of the transmission shaft for access to the grease point.

The recommended grease for pump lubrication is HARDI Pump Grease Lithium V550, Ref. No. 28164600. The specification is NLGI 1, 550cSt @ 400 C.

Normal service, diaphragm renewal and bearing replacement require different amounts of grease.



Lubrication chart



50 hours
50 timer
50 Stunden
50 heures
50 horas
50 часов

Normal operation
Normal drift
Normalbetrieb
Fonctionnement normal
Operación normal
Нормальная операция

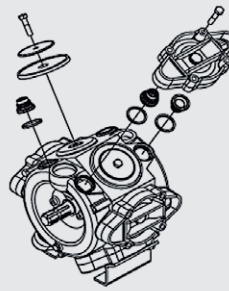

Diaphragm renewal
Membran fornyelse
Membranerneuerung
Renouvellement diaphragme
Renovación de diafragma
Обновление Диафрагма

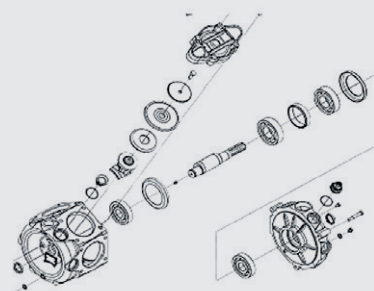

New bearings
Nye lejer
Neue Lager
Nouveaux roulements
Rodamientos nuevos
Новые подшипники

Model	NORMAL DRIFT – 50 HOURS		DIAPHRAGM RENEWAL		NEW BEARINGS	
	Gram total	Ounce total	Gram total	Ounce total	Gram total	Ounce total
500 - 503	6	0.2	40	1.4	60	2.1
600 - 603	10	0.4	60	2.1	100	3.5
321	10	0.4	60	2.1	100	3.5
1200 - 1203	13	0.5	90	3.2	130	4.6
1300 - 1303	3 x 5	3 x 0.2	3 x 35	3 x 1.2	3 x 50	3 x 1.8
360 - 363	50	1.8	350	12.4	500	17.6
364	2 x 30	2 x 1.1	2 x 200	2 x 7.1	2 x 300	2 x 10.6
460 - 463	50	1.8	350	12.4	500	17.6
464	2 x 30	2 x 1.1	2 x 200	2 x 7.1	2 x 300	2 x 10.6

Lubrication

The amount of grease needed depends on the intervention.

A table from the instruction book will describe the amount needed.

To determine the amount of grease delivered from a grease gun, pump 10 full strokes onto a scale to measure the weight delivered. Now you can calculate the amount with more or less grease gun pump strokes.

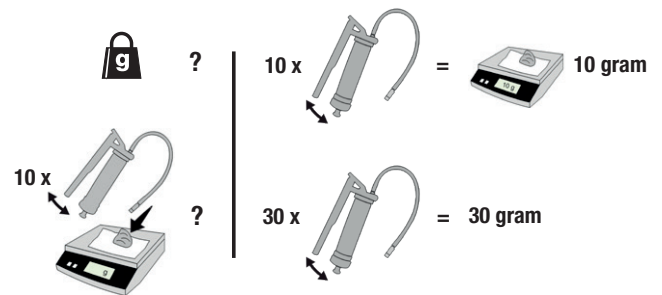

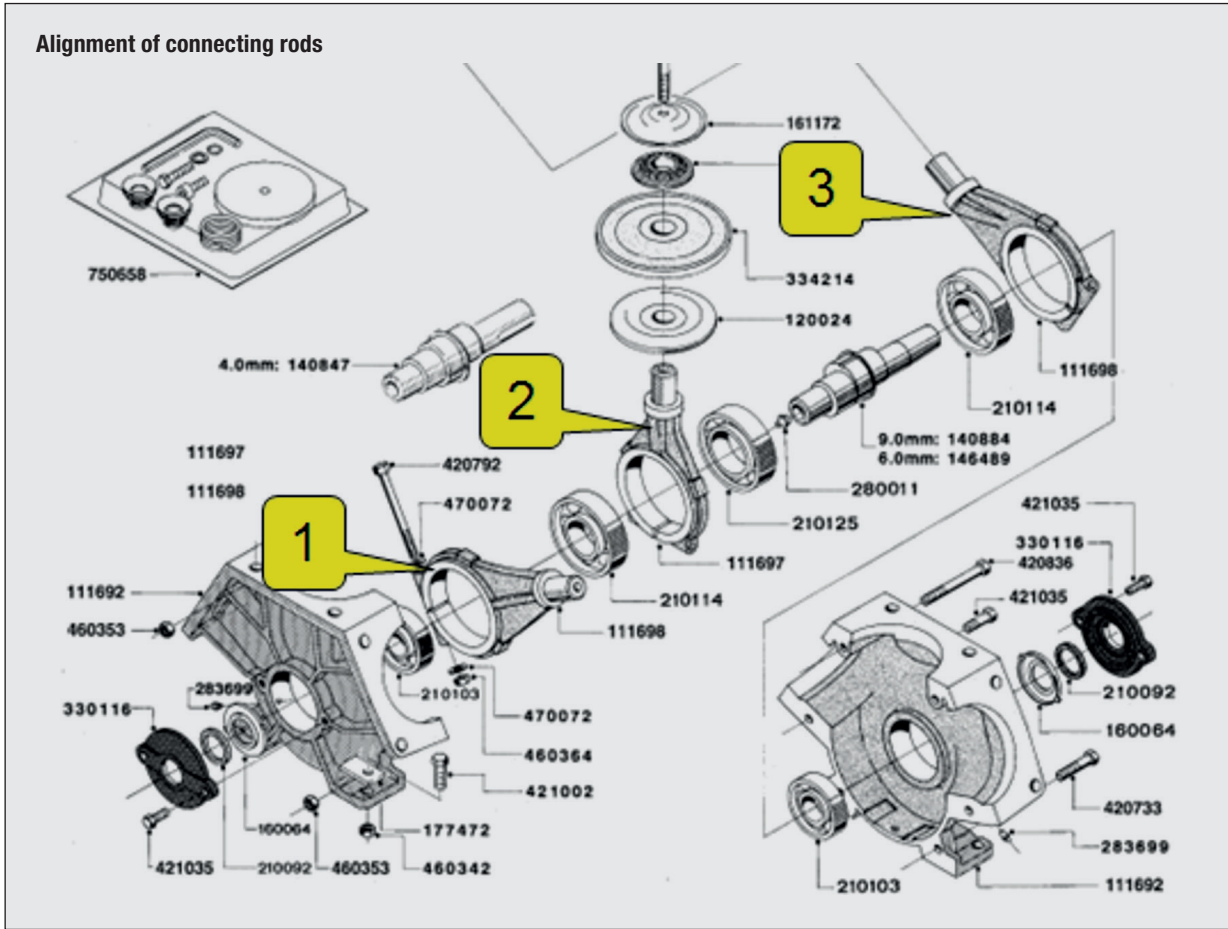

Connecting rod position for models 600, 320, 1200 and 1300

If the pumps are completely disassembled for bearing replacement, it is important to place the connecting rods correctly at re-assembly. Failure to do so will cause excessive pulsations in the liquid delivery.

The parts drawings are quite helpful as they show the correct orientation. Looking from the transmission shaft side, the first connecting rod must be orientated so it points to the right.

Alignment of connecting rods



Correct assembly of the connecting rods on a model 1303 pump with pump shaft facing you. If you “shake hands” with the pump, the first connecting rod is always on the right-hand side.

Torque settings

Pump model	Valve cover (Nm)	Diaphragm cover (Nm)	Diaphragm bolt (Nm)
503 & 603	50	50	25
321	60	60	60
1203 & 1303	80	80	80
364 & 464	90	-	90

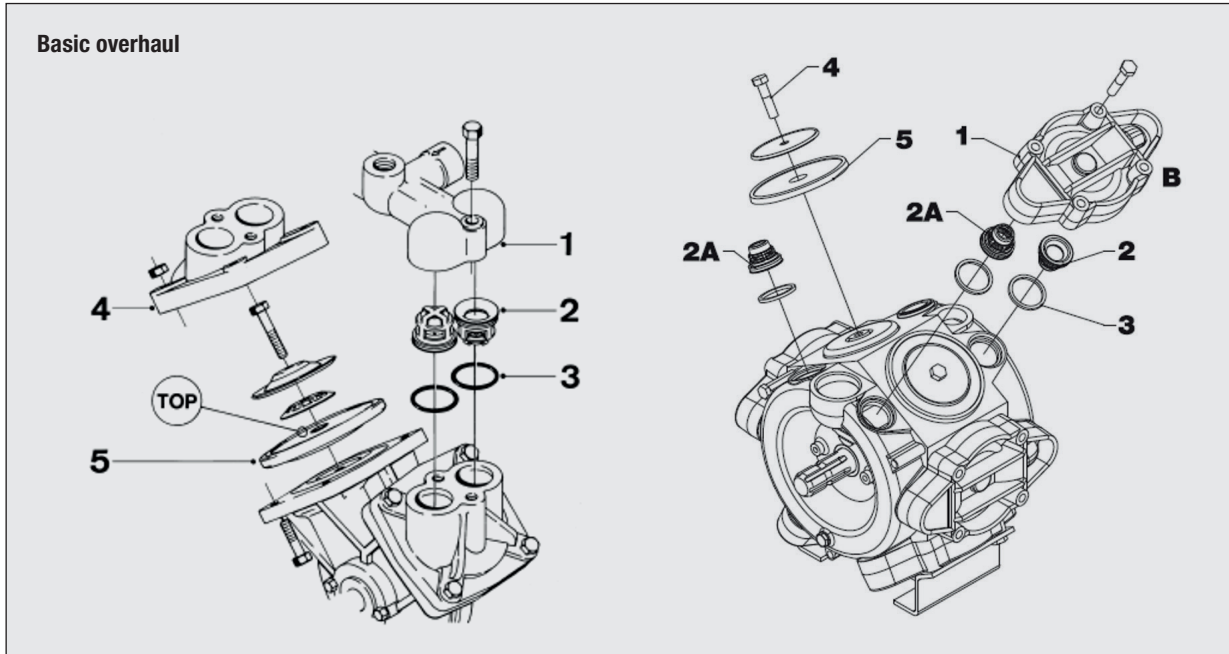

Changing valves and diaphragms

If the pump leaks liquid from the crankcase, the diaphragm needs to be changed. If the liquid system cannot aspirate and produce pressure or it is pulsating, it may be a damaged valve. Before opening the pump, it is wise to have a pump kit on hand. The sprayer instruction book gives you more specific details. General guide:

Valves

- ▶ Remove the covers (1).
- ▶ Before changing the valves (2), note the orientation.
- ▶ Note that on the older 6 diaphragm pumps, one or two valves with an air bleed hole in the valve flap are used. They are colour-coded white.
- ▶ Note the placement (2A).
- ▶ Use new gaskets (3) at re-assembly.

Diaphragms

- ▶ Remove the diaphragm cover (4).
- ▶ The diaphragm (5) can now be changed. Note the orientation with "TOP" on the upside.
- ▶ Do not distort it when re-tightening the covers as the diaphragm will not seal properly.
- ▶ Re-grease the pump if liquids have reached the crankcase.
- ▶ Do not over-grease and check the drain hole is clear.

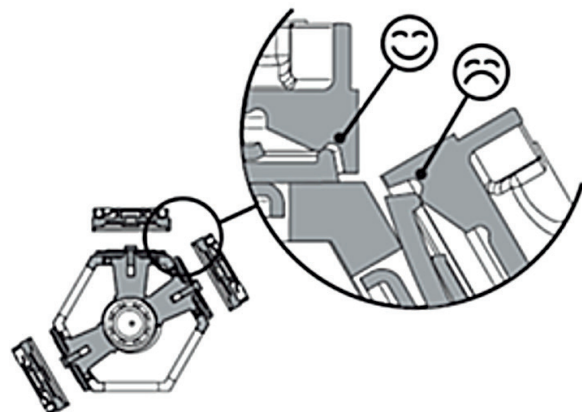

Older (black) and new version (yellow) diaphragm for model 1200 and 1300 series pumps

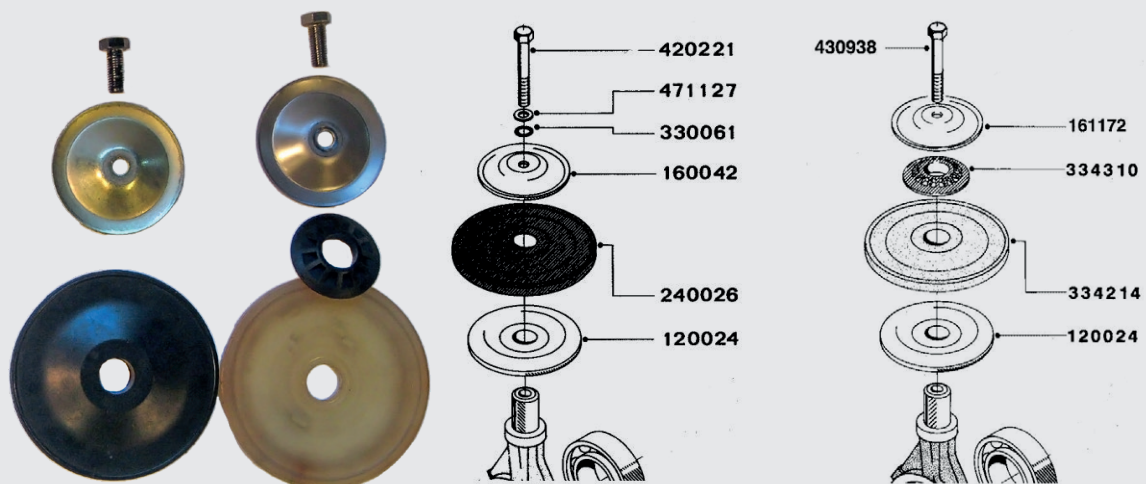

Diaphragms and older pump models

The diaphragm material and shape has changed over the years. The older diaphragms were thicker, coloured black and made of nitrile. The present diaphragms are thinner, yellow in colour and are made of polyurethane. They have "TOP" on the side that is to face up. The new material has better resistance to chemicals and the thinner diaphragm has a longer mechanical life.

The new design diaphragm can be fitted to the older pumps. Spacers are supplied in the overhaul kits. Top plate and bolt are now made of stainless steel for a longer life and these are also supplied in the overhaul kit.



Typical faults and remedies



Over-greasing

This will hinder or block crankcase drainage. Only the bearings require lubrication.



Cavitation

This is caused by a high vacuum on the suction side of the pump. The high vacuum is in turn caused by under-dimensioned suction lines and fittings, a flow restricting suction filter or a blocked suction filter.



No filtration

Pump valves jammed with foreign objects indicate that filled water has not been filtered. If using a filling device, place a filter on the filling line before the liquid reaches the sprayer.

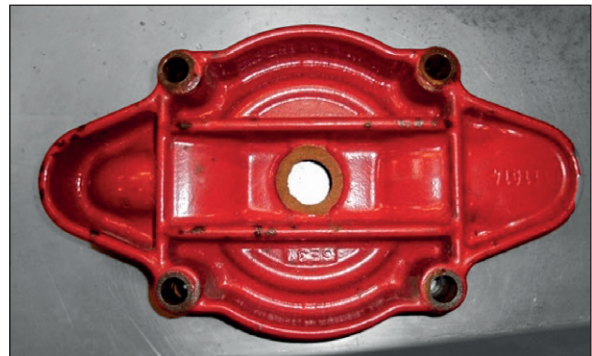

Wrong parts; damaged diaphragm covers

This is due to an incorrect combination of connecting rod and crankshaft. These parts are matched i.e. 10 mm con-rod is for a crankshaft with a 10 mm stroke.



The picture shows an in-line suction filter (Ref. No. 72050000) for 2½" hose with a course 30 mesh filter insert.

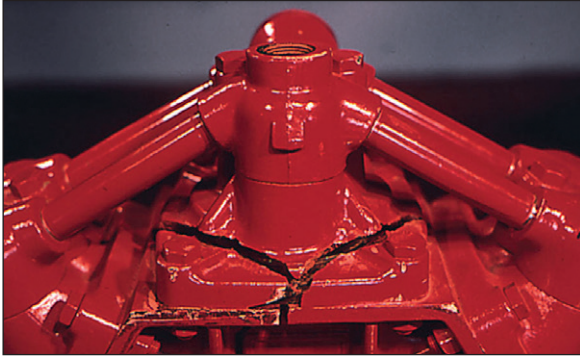

Frost damage

The best preventative to frost damage is running the sprayer with anti-freeze (glycol) before winter storage. Some pumps are equipped with drain plugs but draining the pump will not guarantee frost damage to other parts of the sprayer.

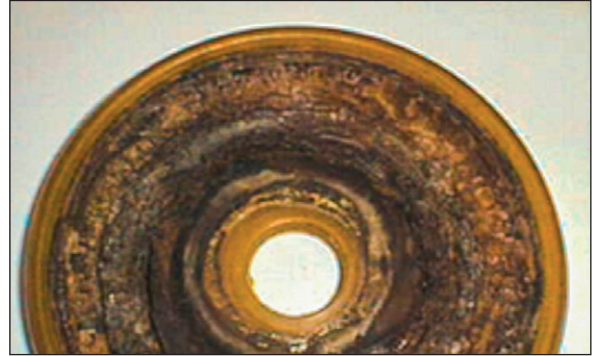

Chemical damage

Pesticides using petro-chemical solvents are very harsh on synthetic components. They typically have an odour similar to kerosene. The diaphragms will swell and begin to flake. If the sprayer has not been cleaned before storage, this will leave the components in contact with the solvent for a long time and chemical damage may be expected.



Mechanical damage

Normal mechanical lifetime for diaphragms is approximately from 1000 to 2000 hours. If the spraying is always done at high pressures and/or high revolutions, this will shorten the diaphragm life. Damage will look like a knife cut.

Once the diaphragm is perforated, the pump will leak liquid from the crankcase.

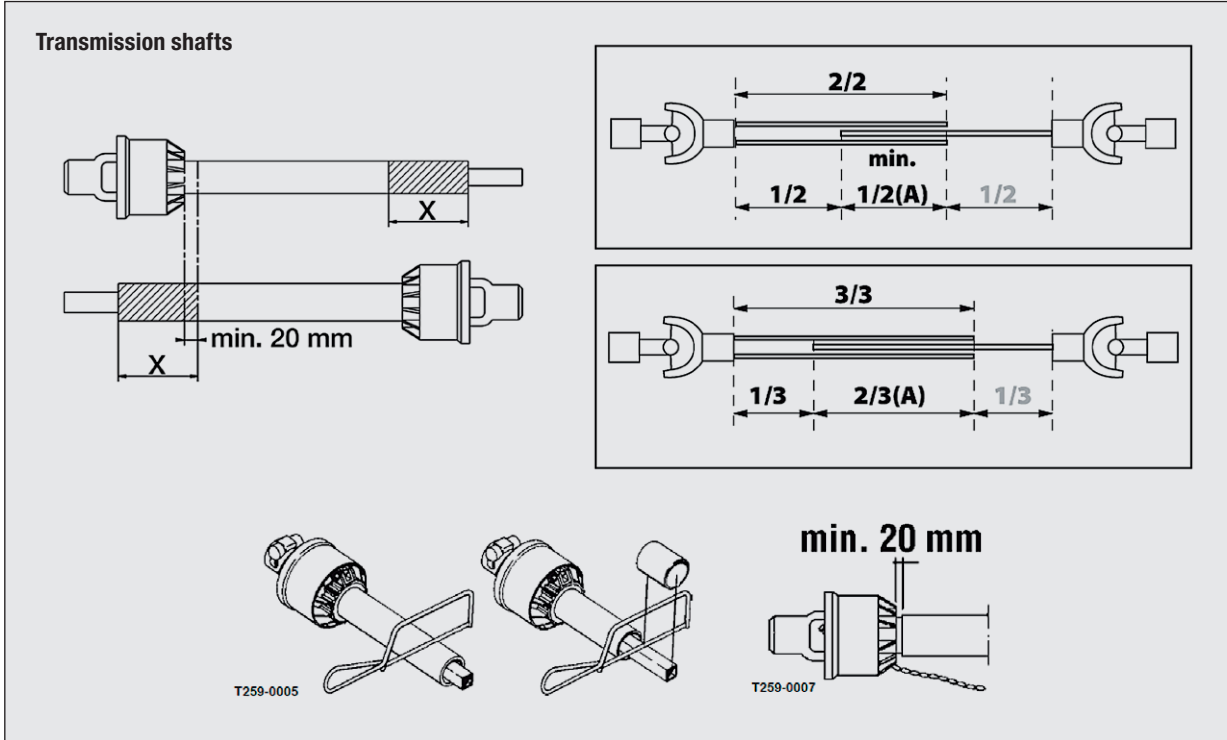

Transmission shaft

The transmission or Cardan shaft supplies power from the tractor to the sprayer. Universal joints allow for changes in alignment. For applications where the angle between tractor and sprayer are acute, a wide-angle shaft should be used otherwise the universal joint bearings will be damaged.

The shaft may need to be shortened at the first installation. If it is too long, it or the pump will be damaged. Before installation, set the sprayer and tractor so the shortest distance possible is found between sprayer pump and tractor P.T.O. Now compare with the transmission shaft and shorten if needed. The recommended overlap (A) should be $\frac{2}{3}$ of the shaft length. The shaft must have a minimum overlap (A) of $\frac{1}{2}$ the length.

For operator safety, the transmission shaft guards must be intact and must not rotate. Avoid angles greater than 15° as this will shorten bearing life. Refer to transmission shaft instructions supplied with the shaft.

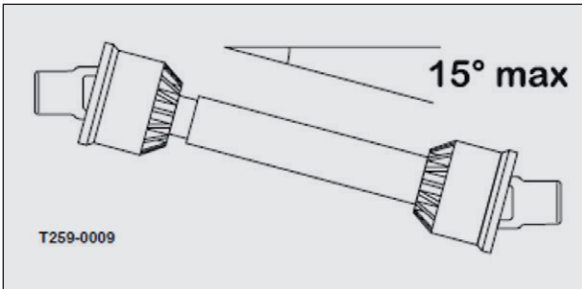
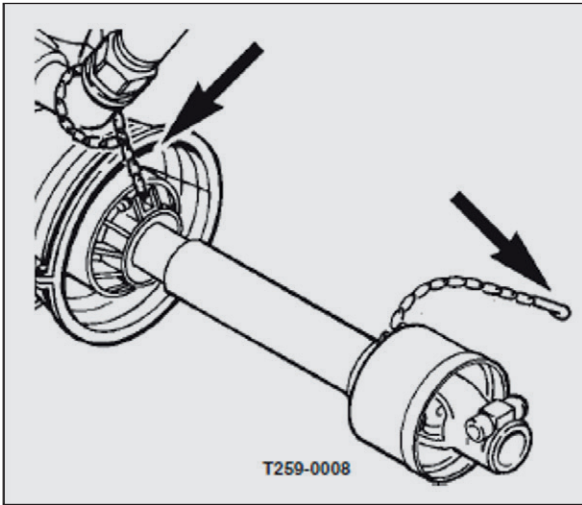

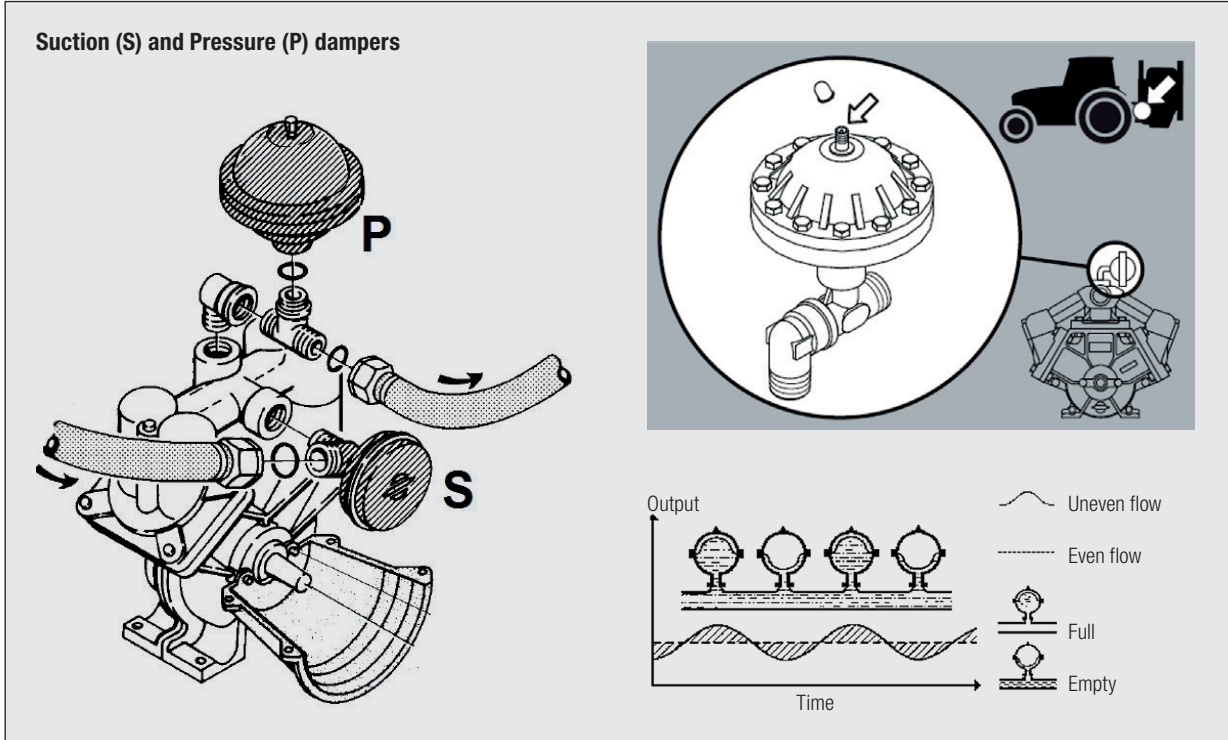

Suction and pressure damper

Many of the smaller pumps can be supplied with a suction **(S)** and pressure **(P)** damper. The dampers remove the pulsations caused by the small number of diaphragms. The 6-diaphragm pumps do not require a suction or pressure damper

The suction damper is a passive diaphragm and does not require control. The pressure damper is pre-charged from the factory with 2 bar (30 psi) pressure.

To check for a damaged pressure damper diaphragm, first unscrew the damper from the “T” piece and then shake it. If you hear a sloshing sound, it is damaged.

Spray pressure bar	Damper pressure bar	Spray pressure psi	Damper pressure psi
1.5-3	0-1	20-45	0-15
3-15	1-3	45-220	15-45
15-25	3-4	220-360	45-60





CHAPTER 2

Controls

Control types overview

As a general rule, red coloured components on HARDI control e.g. levers, handles; knobs etc. indicate a point of operation, i.e. something that can change position.

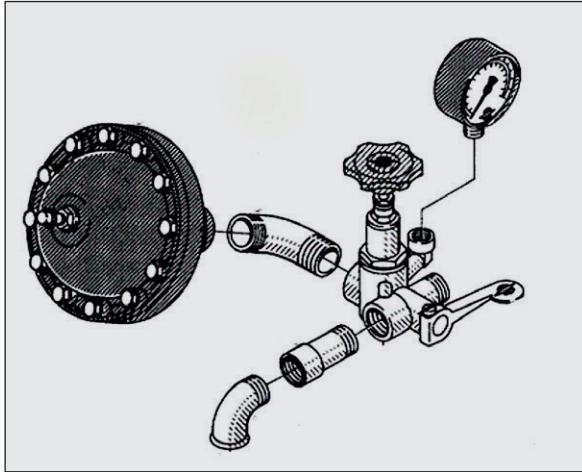

M-600 control unit

This is a simple brass control unit with pressure gauge and pulsation damper. It is suitable for direct attachment to pump. Like all pressure controls, the pressure regulator basically punctures the pressure line to reduce spray pressure. The more liquid that returns to the tank, the lower the spray pressure.

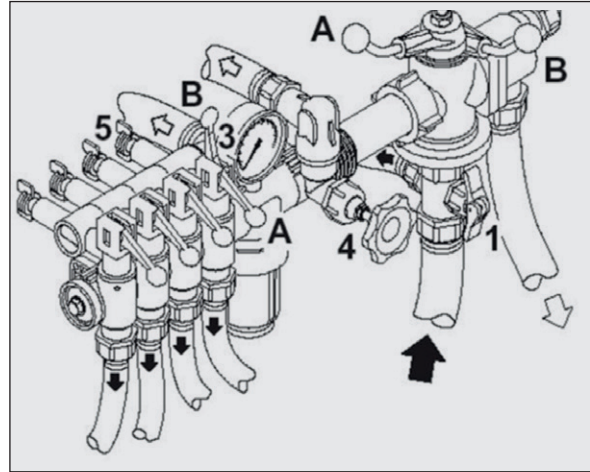

BK control unit

The pressure regulation and main ON/OFF with safety valve are two separate units. This permits the use of the HARDI-MATIC volumetric valve allowing constant application rate even with speed variations if the tractor is kept in the same gear. It has a built-in pressure filter and pressure equalization device in the section valves that maintain the same pressure when the section valve is turned off. The hydraulic tank agitation can be turned off to reduce foaming and thereby utilise total tank contents.

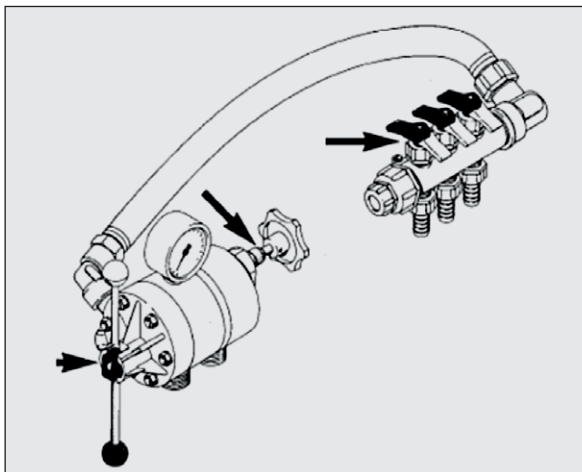

M-70 control unit

It is a basic unit made of synthetic materials with pressure regulation and safety valve in one unit. It is often used with a simple distribution valve with up to three sections.

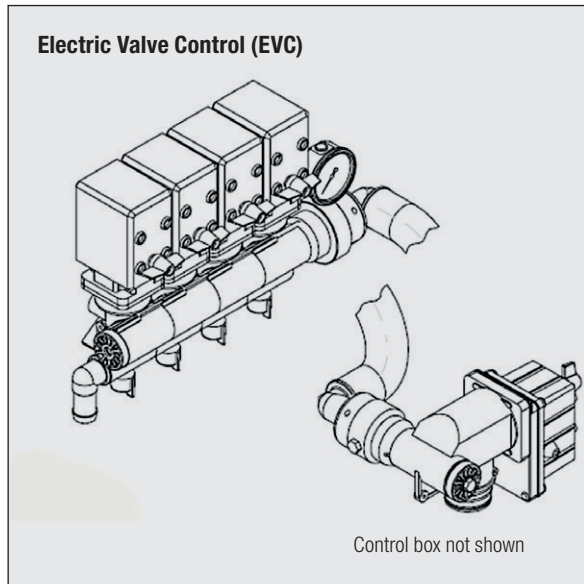

Electric Valve Control (EVC)

This is a remote-controlled unit utilizing 12 Volt motorized valves (not solenoid) to operate the spray functions. If connected to a sprayer computer, it can maintain the application even when changing the tractor gears. The HARDI-MATIC volumetric pressure regulation valve for constant application rate is built into the pressure regulation system. It can have from two to nine section valves that have the equalization device maintaining the same pressure when section valve is turned off. It uses a radial sealing system that offers better sealing than facial sealing.

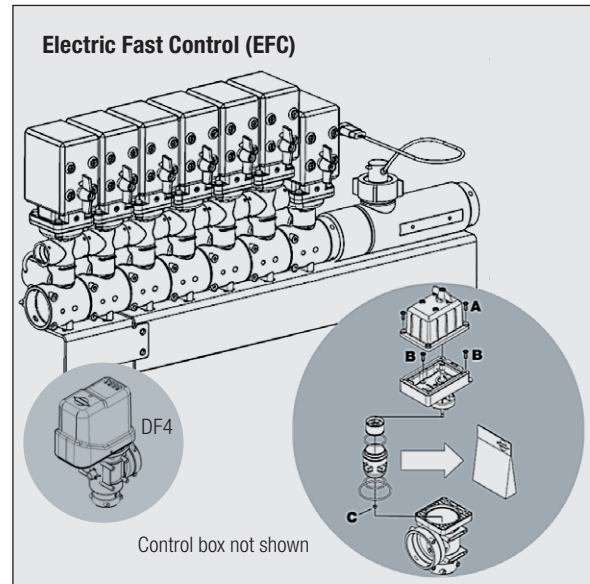

Electric Fast Control (EFC)

This is a high capacity remote-controlled unit similar to the EVC. It requires a controller as the equalization system has become automatic. Up to 13 section valves can be used. In 2011, the pressure regulation valve was upgraded with a new regulation valve DynamicFluid4 (DF4) that minimises wear and leakage.

Discontinued control units

Air Control (AC):

From the early 80's, this short-lived system used pneumatic valves.

Electric Control (EC):

The first of the 12 Volt motorized valve controls started life in 1982. It included a main ON/OFF valve. This unit was superseded by the EVC.

Solenoid Control (SC):

Low cost solenoid system. It was discontinued in 2004.

Electric Manual Control (EC/BK):

This economic unit had electric pressure regulation and main ON/OFF with manually operated section valves. It was discontinued in 1995.

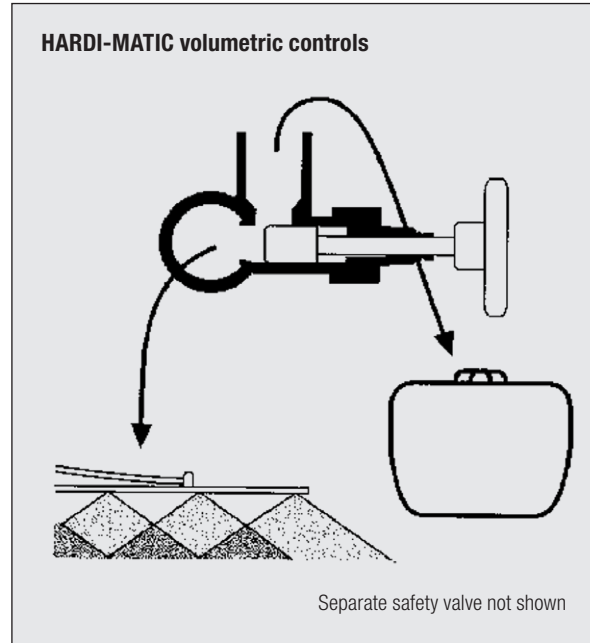
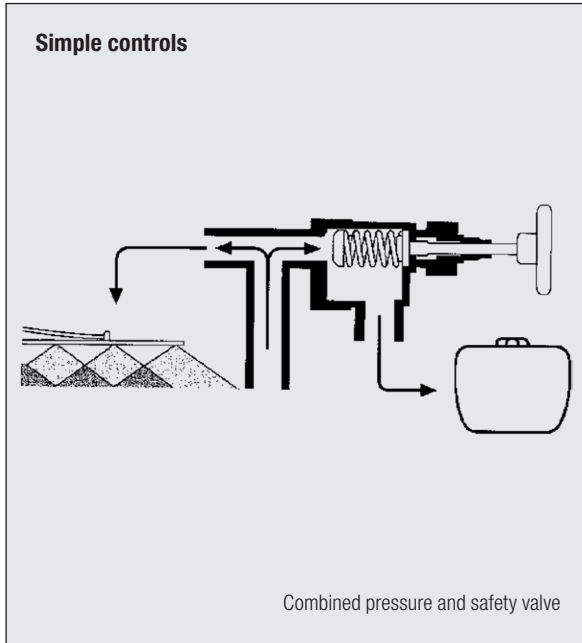

HARDI-MATIC pressure regulation valve volumetric control

The HARDI-MATIC is a simple method to maintain a constant application rate. When spraying, a certain percentage of the liquid goes to the nozzles, and the remaining liquid returns to tank. With a HARDI pump, increasing revolutions within the working range also proportionally increases the flow output to both nozzles and to tank. The percentage division remains the same. With a simple regulation valve control, changing engine and thereby pump revolutions changes the application rate. With the HARDI-MATIC system, changing engine revolutions does not change the application rate. This is because the valve opening is fixed, unlike the simple system where the spring assembly would allow the opening to change.

HARDI-MATIC is a simple handy feature when the operator changes engine revolutions e.g. to reduce spray drift with lower revolutions or when working in hilly terrain when the tractor will speed up downhill and slow down uphill.

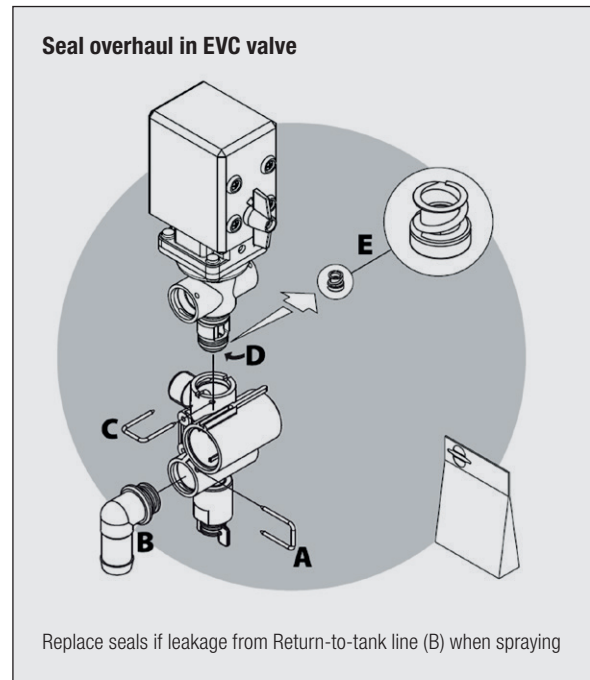
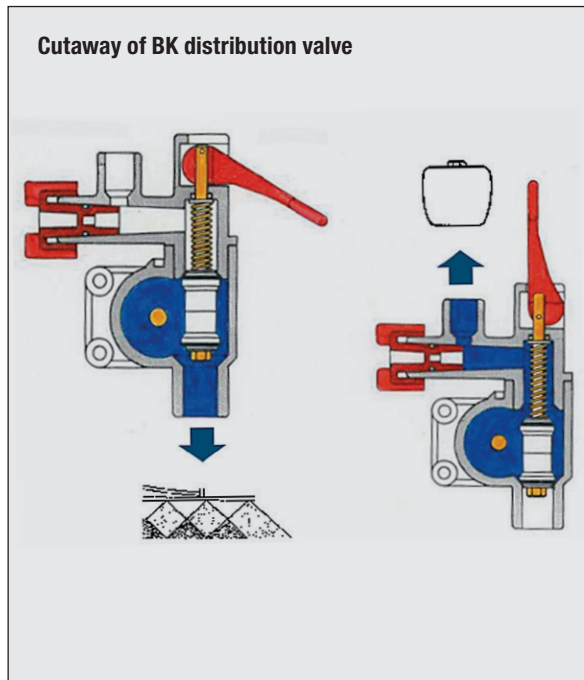

Principles of pressure equalisation

A simple distribution valve divides the liquid up to the various boom sections. It is advantageous to have many sections as less spray is wasted on irregularly shaped fields. Closing a section will normally cause the pressure to rise. The operator or computer will need to intervene and reset the pressure.

The pressure equalisation system is basically a calibrated two-way valve. When spraying, the return to tank line is closed. Closing the spray line opens the return to tank line. The pre-calibrated orifice has the same flow as the boom section and therefore the pressure does not change. Consequently, calibration on BK and EVC controls is needed when the capacity of the nozzles is changed.

An O-ring and/or a gasket seal the valves. If the sprayer utilises a computer and the seals leak, the electronic read-outs will be misleading. 3000 litres sprayed out will be registered as e.g. 3500 litres. This is because the liquid that is supposed to go to the nozzles has gone back to the tank and then been recycled through the flow sensor on the way to the nozzles again.

The seals can be checked by removing the return to tank line. It should have no liquid flow when the boom spray lines are all open.

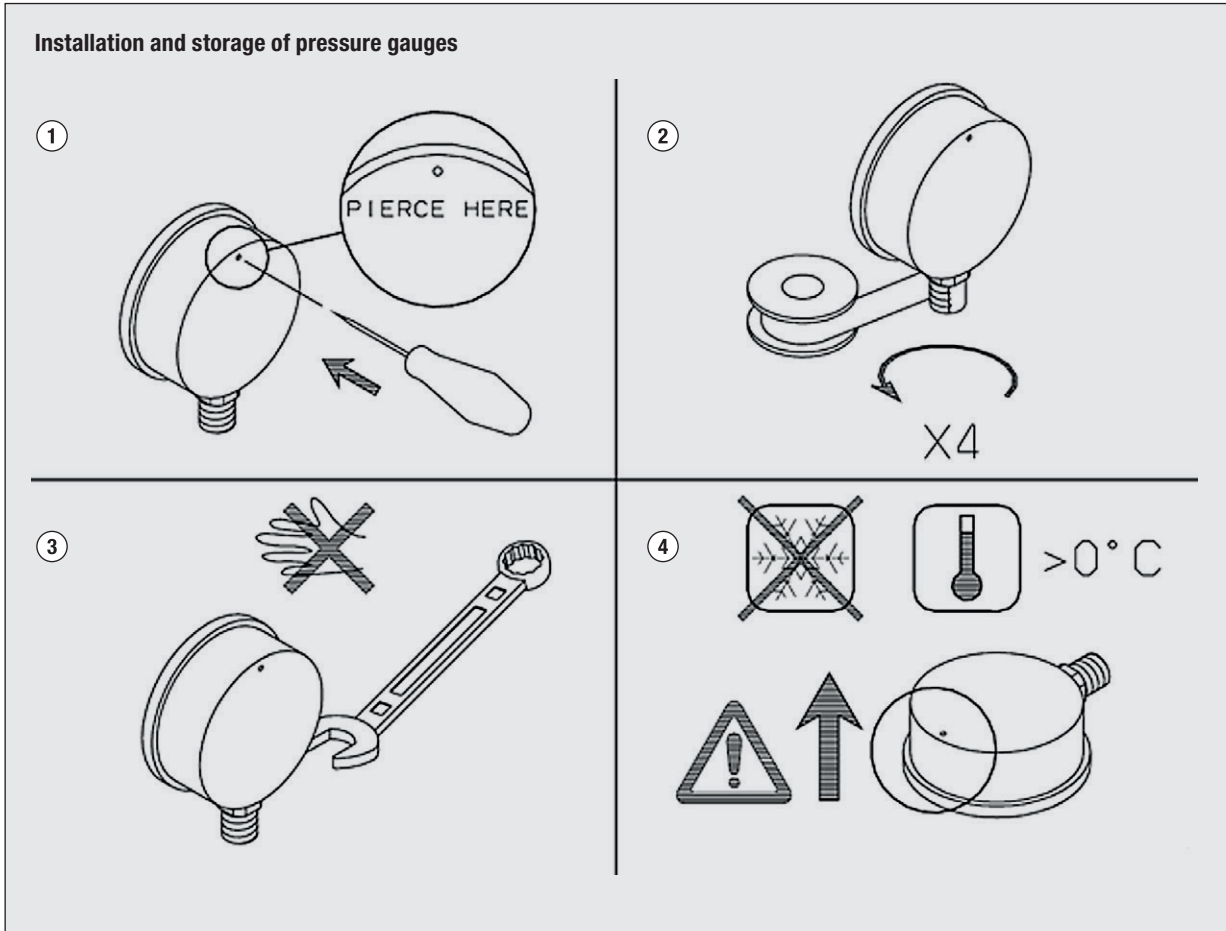

Pressure gauges

The pressure gauge is the sprayers' version of an expensive wrist watch. This component is often the only visual indication to the operator that "all is well".

Most field spraying is done between 1.5 to 5 bar (20 to 70 psi). The gauge should be accurate and large enough for the operator to see the value. The HARDI sprayer safety valve opens at about 15 bar (220 psi) so a traditional gauge with an evenly spaced scale would be hard to read accurately. A large diameter (100 mm/4") split-scale gauge is easier to read.

The gauge is liquid filled (glycerine) to protect against vibrations and prevent internal condensation. It has a vent at the top of the gauge that must be opened once the gauge is installed. It is recommended to store the gauge in a frost-free environment.



Functions diagram

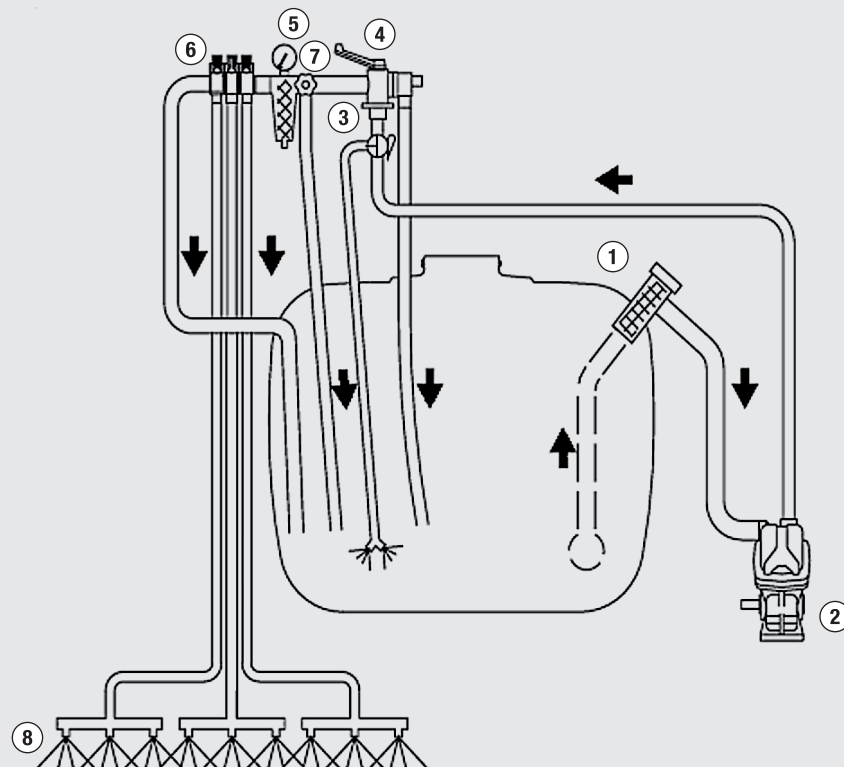

Basic sprayer functions

- 1 Suction filter; the suction point is located at the bottom of the tank
- 2 Pump
- 3 Pressure agitation valve
- 4 Main ON/OFF valve with built-in safety valve and return line to tank
- 5 Pressure gauge
- 6 Section valves with pressure equalization return to tank line
- 7 HARDI-MATIC pressure regulation with return line to tank
- 8 Boom sections with nozzles

The liquid not sprayed out through the nozzles is returned to the tank. The suction filter is relatively coarse (30 mesh) and protects the pump valves from damage. The ability to turn off pressure agitation at the near end of emptying the tank reduces the risk of foaming and this increases the ability to completely empty the tank. The safety valve, usually set at 15 bar (220 psi), must be located before the main ON/OFF valve.

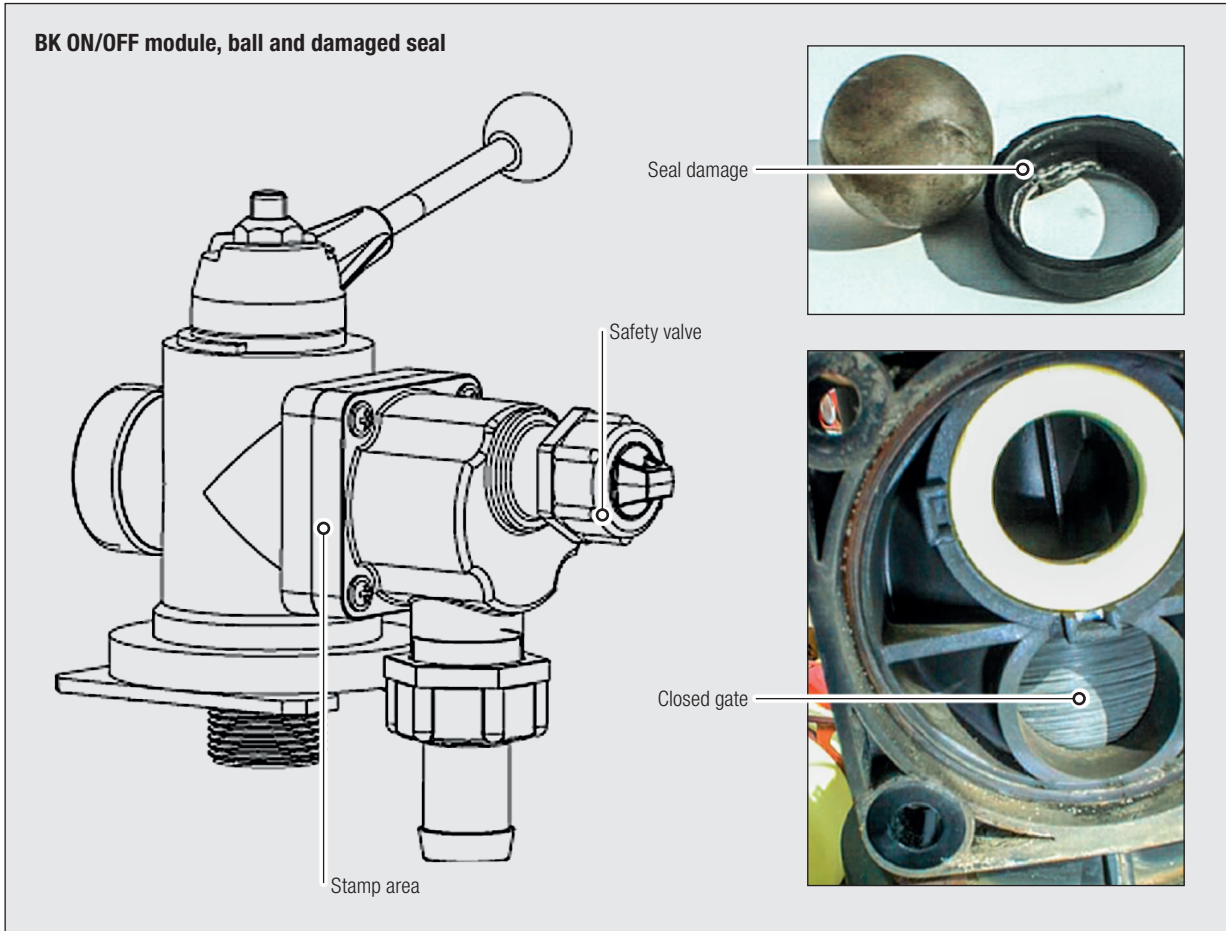

BK controls

The safety valve is incorporated into the ON/OFF module of the valve. The pre-set maximum pressure is now 15 bar (220 psi). On older units, this could be adjusted via a knob on the side of the unit. For BK controls used on vineyard and orchard sprayers, it may be a 25 bar (375 psi). The value is stamped on the side of the housing.

The ball seal (hence the name BK, Ball Control) prevents spraying when the valve is turned off.

If the sprayer leaks at the nozzles when the main ON/OFF is off, a damaged ball seal is most probably the cause. Lack of correct cleaning will typically be the cause of damage.

If liquid returns to tank from the main ON/OFF valve when in spraying (ON) position and thereby reducing capacity, the close-off gate is worn. It can become scored from poor quality water or powder formulated pesticides.

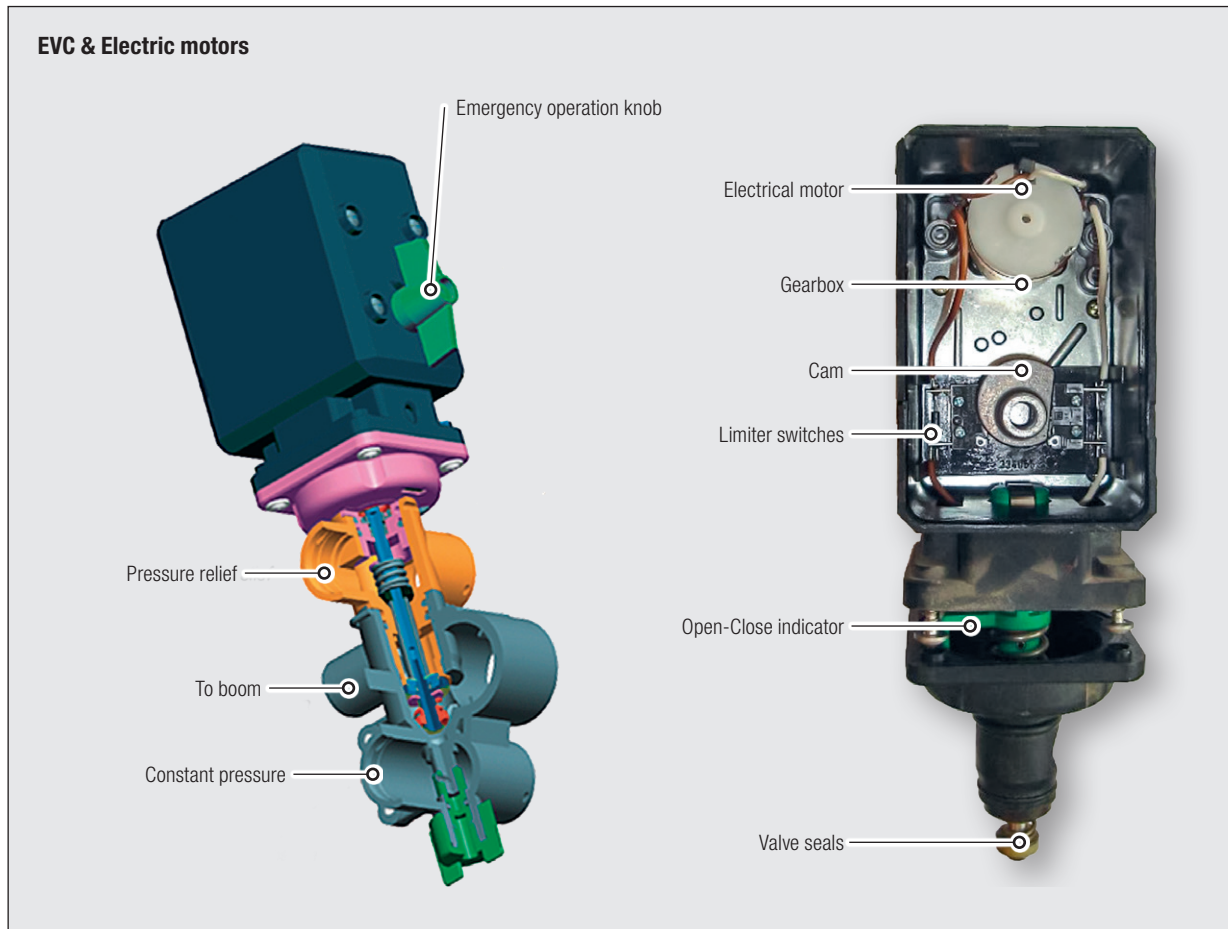

EVC controls

The electric controls utilise a motor with gearbox to open or close the valve. This is a more secure operation than a solenoid valve. It also allows for manual operation should there be a power failure. To operate manually, first disconnect the cable from the control box to the control unit. This will ease operation as it will not function like an electrical brake when disconnected.

The pressure equalisation adjustment knob and return are at the bottom of the valve. A pressure relief return is also incorporated into the EVC. It relieves the pressure in the hoses to the nozzles as soon as the valve closes as the hoses can cause the nozzles to continue to spray for a short while after the section valve is closed.

The knob colour is a code. It may indicate age and motor speeds.

Red knobs are on the oldest versions. Motor to spindle ratio is 1:300.

Yellow knobs on the pressure regulation indicate a faster 1:150 ratio.

The gearbox never wears out but the limiter switch and the seals for equalization can wear and need replacement. If the limiter switch does not click, it is probably faulty. If the valve becomes slow to turn, the motor is usually damaged. This can be due to overheating or use of incorrect fuses.

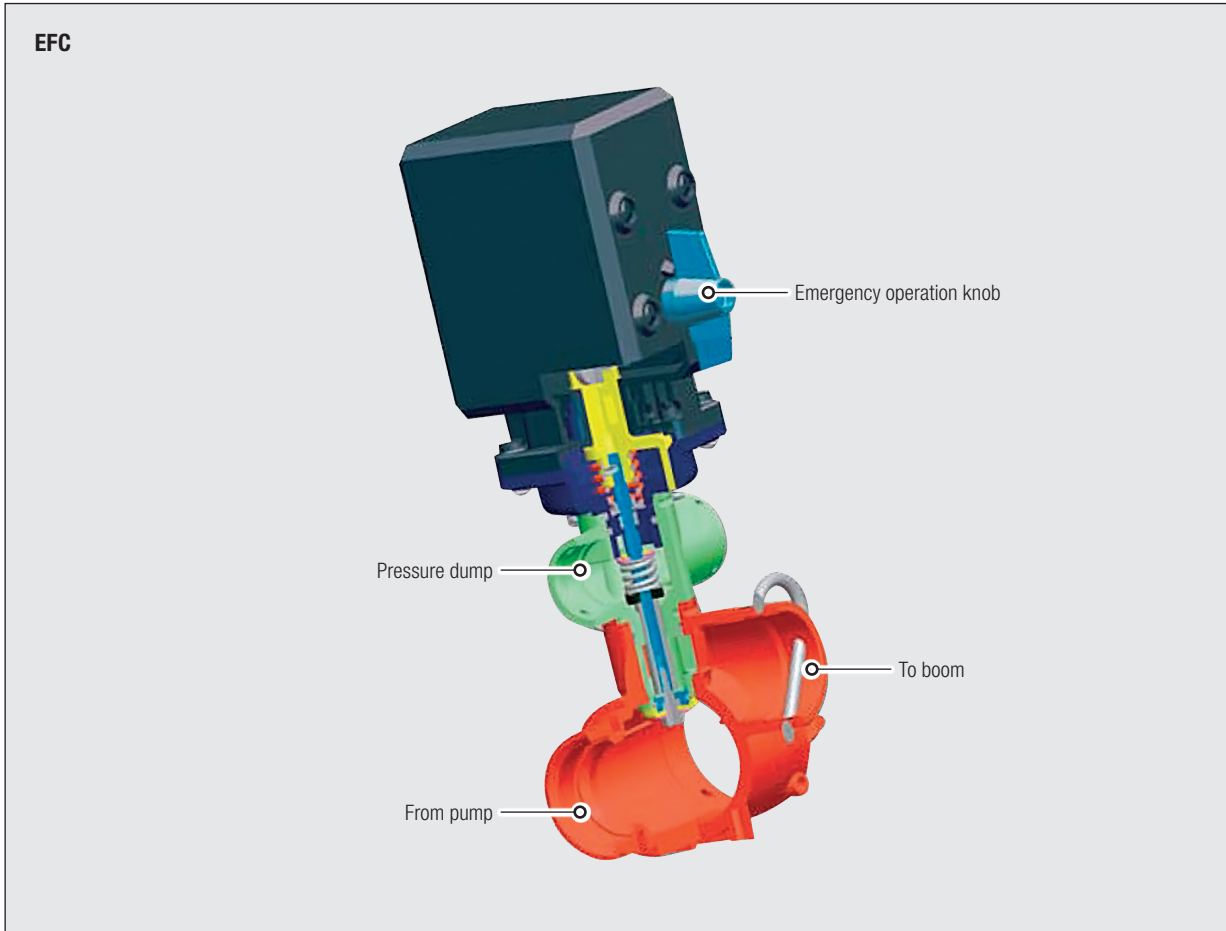

EFC controls

The high capacity EFC is used with a HARDI controller.

The modular section valves have a pressure dump to stop nozzles from spraying when the section is turned off. Without this, small capacity nozzles and/or wide booms e.g. over 30 metre (90ft) would continue to spray until the pressure in the hose is less than 0.3 bar (5 psi), being the closing pressure of the green coloured non-drip nozzle check valve. When a section is operated, the pressure equalization is executed by the controller. Manual calibration of the pressure equalization is therefore not needed.

The pressure regulation valve basically punctures the pressure line to reduce the spray pressure. Increasing the return to tank or suction line lowers the pressure.

The valve consists of a ported cylinder and a piston inside the cylinder. Some versions of the cylinder and piston are all synthetic material whilst others are stainless steel and ceramics to combat wear and internal leakage which reduces the sprayer capacity.

An encoder monitoring the piston position was used for the HARDI LookAhead regulation software.

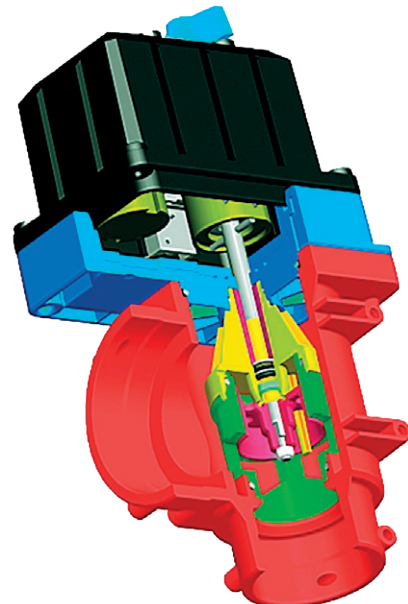

DynamicFluid4 is active even when not spraying

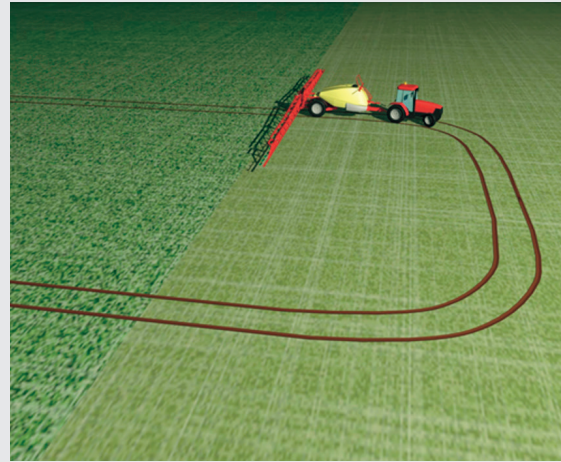
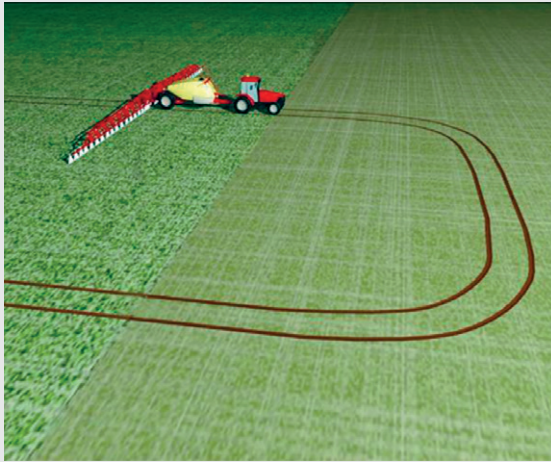

DynamicFluid4 regulation system

To obtain the correct application rate, the classic spray regulation system is based on reaction to a mistake, meaning the sprayer needs to be spraying and to be off target before it can be regulated. It can take a relatively long time before application rate is back on target again and is extremely challenging for a sprayer when conditions rapidly change, like at spray start with a rapid change in speed, turning sections off or on and on-the-go dosage change. Modern tractors with power shift and constant velocity transmissions are also a big challenge to fast-on-target application rate.

The revolutionary DynamicFluid4 regulation system foresees the correct setup and is very fast in reaching on-target application rate. It was introduced in 2011 to the COMMANDER sprayers and now is available on the self-propelled, NAVIGATOR and MEGA sprayers.

The extra sensors and the software behind them make the system more robust. Should a sensor fail, the operator can often finish the job and do the repair at a more convenient time.

The reason for using ceramic discs or a combination of stainless steel and synthetic discs is to reduce internal leakage and wear resulting in higher capacity and less time spent on repairs.



Sensors and monitor pints of the DynamicFluid4

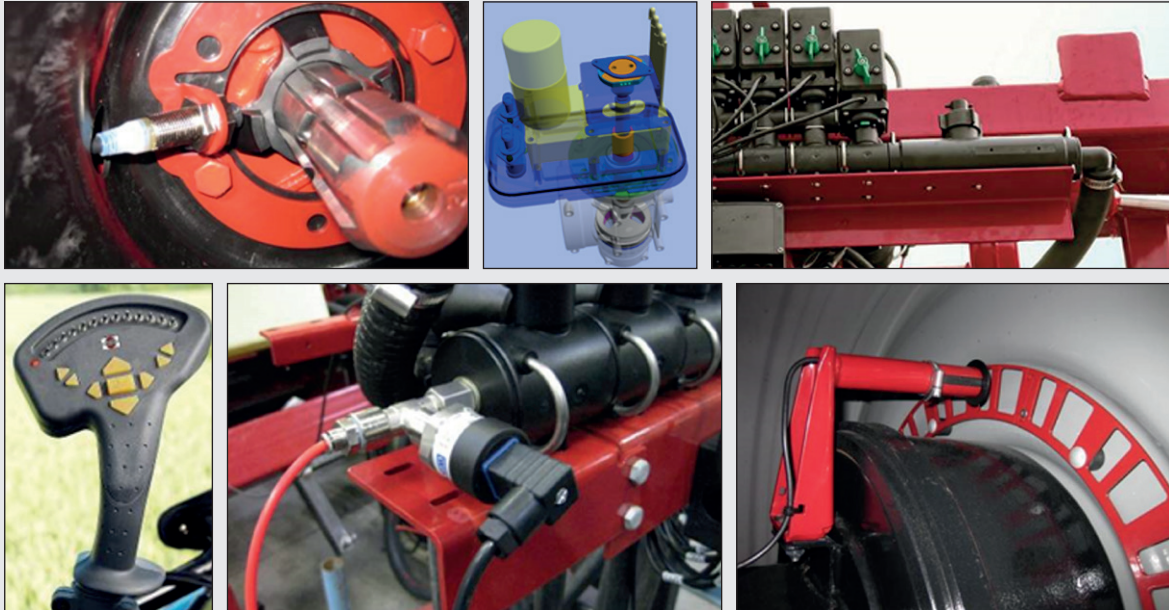

DynamicFluid 4

DynamicFluid4 is based on 4 sensors in the fluid system. The sensors are the pump revolutions, angle of the regulation valve, flowmeter and pressure sensor. The speed sensor is also used in the calculations. DF4 monitors the flow required to the nozzles in respect of the flow to agitation, pressure filter return and regulation valve. It takes into account pressure differences from pump to nozzle, pressure transducer height and active boom sections.

During the spray job, there are two situations; nozzles ON or nozzles OFF.

With nozzles ON, sensor input to regulation system is live.

With nozzles OFF, the regulation system is now based on a simulation of previous spray situation.

We call this FeedForward and it foresees the correct opening of the regulation valve and thereby is extremely fast to obtain the correct application rate.

Even when closing all but one nozzle on a very wide boom, the application rate is quick to achieve, correct and stable.



CHAPTER 3

Filters and non-return valves

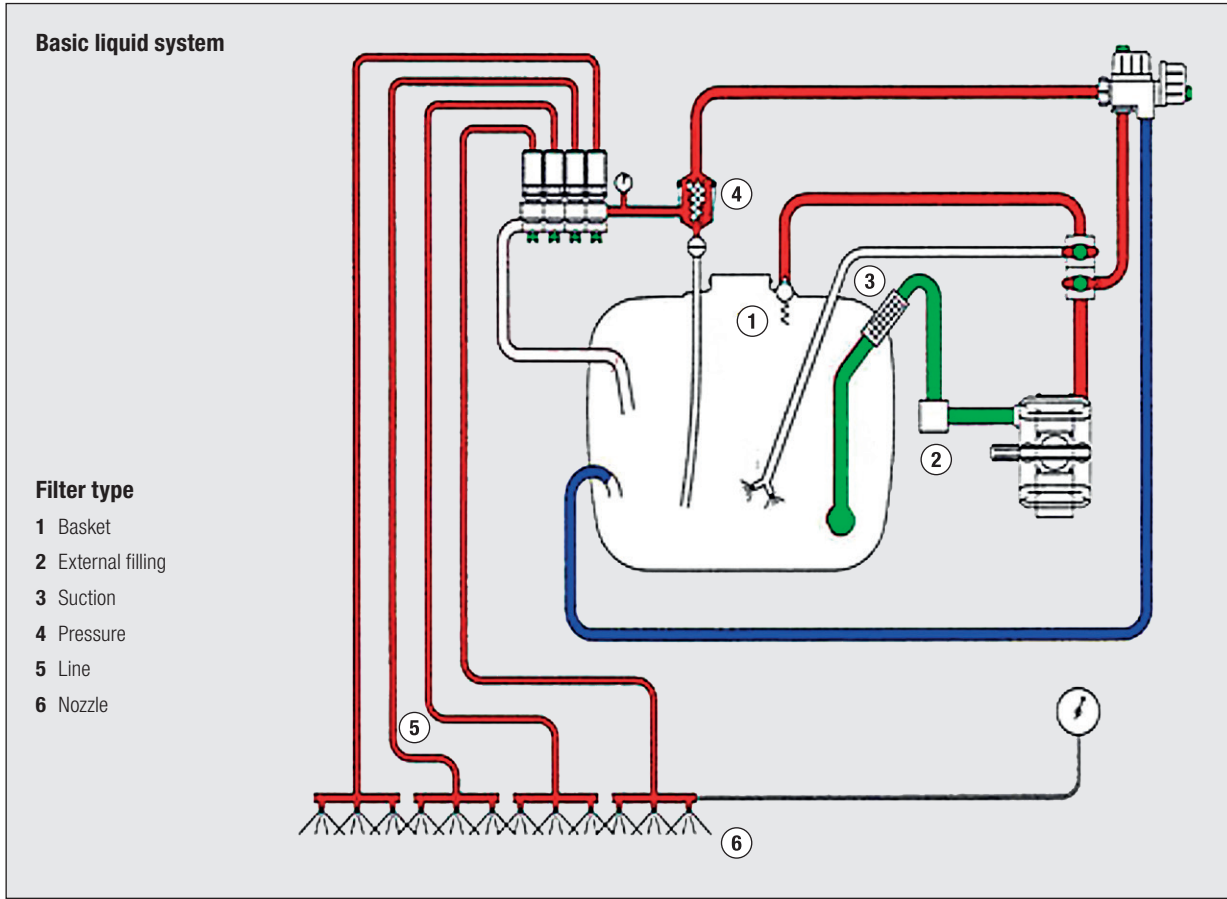

Filtration

The nozzles may be blocked with impurities in the water used, the pesticide itself and scaling from the tank and spray lines.

The filters become finer the closer they are to the nozzles. The basket and suction filters are coarse and their primary task is to protect the pump components. The pressure filters should prevent nozzle blockage.

If the impurity can pass through the nozzle, it should not be stopped by the filter mesh. This is overkill of filtration. The filters will need cleaning more often if the mesh is too fine. If the suction filter is too fine, it may also cause pump cavitation.

A good filter design prevents spillage of fluid as spot pollution of residues may occur. It should be easily accessed, intuitive to service and have embedded seals.

Self-cleaning filters have a return line back to tank to remove the impurities from the filter. The return line is restricted to prevent pressure loss. The impurities are removed from the system when the tank is cleaned.

Filter types and mesh

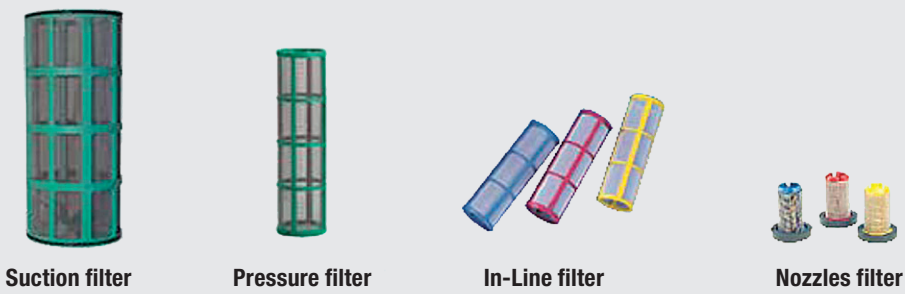

Suction filter **Pressure filter** **In-Line filter** **Nozzles filter**

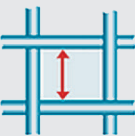
 Mesh		30	50	80	100	Number indicates wires per inch Size of opening
	mm	0.58	0.30	0.18	0.15	

Filter colour-coding and mesh

Mesh is used to indicate the degree of particle filtration. The higher the number, the finer the filtration. The mesh number relates to the number of wires per inch. The opening size is, of course, also governed by the thickness of the wire so the mesh number is a relative indicator.

The filters are colour-coded to aid identification.

Mesh choices

* Standard

Nozzle size

0075-02	100	100	100	80
025-03	* 80 (50)	80	* 80	50
04+	* 50	* 50	* 80 (50)	* 30

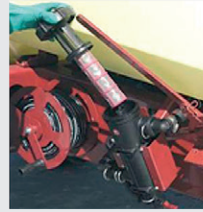

Filter choice

The filter choice in the sprayer is dependent on the nozzle size used. There is no need to “over-filter” the liquid as the result is frequent filter service.

In-Line filters can be added to each boom section to reduce the service intervals of the nozzle filters.

When using the HARDI SNAP-FIT nozzles, the nozzle filter seal is used to hold the nozzle in place.

Top-mounted filters



Suction filters – top mounted

The primary function of a suction filter is to protect the pump components.

The suction filter is located on the top of the smaller HARDI tanks. Reasons are:

- ▶ The filter is always drained when inspected
- ▶ No residues are spilt on the ground
- ▶ There is no need for an ON/OFF valve
- ▶ The filter is located at a good inspection height without climbing up the sprayer

A damaged seal on the suction side will result in hose vibration and reduced pump capacity which in turn will reduce filling and chemical transfer systems efficiency.

The HARDI top mounted filters have a chemical resistant O-ring seal made of Viton. It should be present and not mechanically damaged. If, after spraying and before inspecting the suction filter, you hear a hissing noise from the filter housing, it is a sure sign that the seal is damaged.

The black liquid return hoses must be located away from the suction point of the yellow tube. Failure to drain the tank will be the result if this is not so.

On larger tanks, it is preferred to inspect the suction filter at ground level.

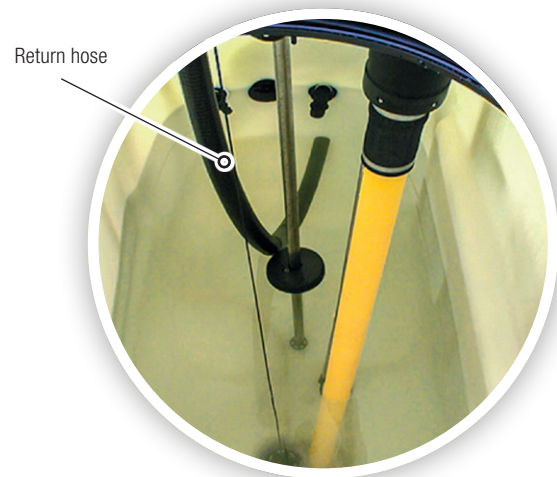

Inside the EasyClean Filter

- 1 Filter housing
- 2 Inlet of liquid, 2½"
- 3 Filter
- 4 Lid
- 5 Dirt trap plates
- 6 Sensor line for vacuum line
- 7 Automatic On/off valve
- 8 Outlet, 2½"
- 9 Drain of filter
- 10 Emergency operation

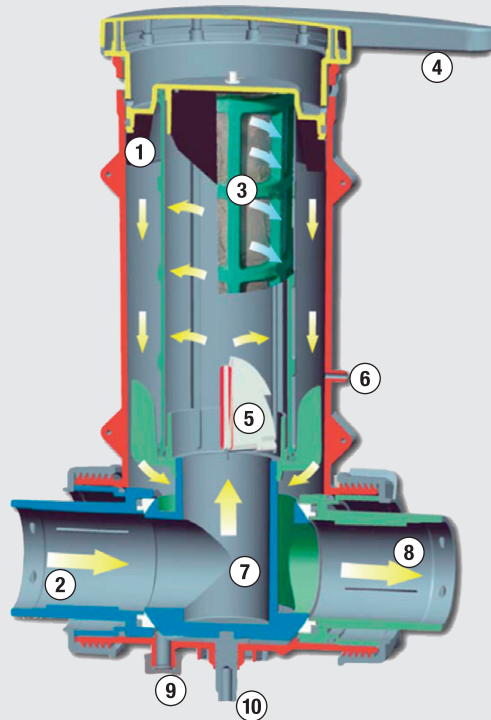

Suction filters – bottom mounted

On larger sprayers, the suction line comes from the bottom of the tank. Therefore, the hoses can be kept as short as possible to minimise residues.

The HARDI EasyClean suction filter with built-in main tank shut-off valve is utilised with the following benefits:

- ▶ The filter can be inspected from ground level
- ▶ The filter is always drained when inspected
- ▶ Objects are removed when the filter is inspected
- ▶ No residues are spilt on the ground

A vacuum gauge is placed in front of the sprayer next to the pressure gauge for the liquid system. It is connected to the suction filter with a small diameter red hose. The gauge is easily seen whilst spraying and indicates when the filter needs servicing.

Turning the one-handed top 90° opens the filter. When closed the handle points forward so the crop is not damaged. The filter is available in 30, 50 and 80 mesh and should be inspected every 30 days during operation.

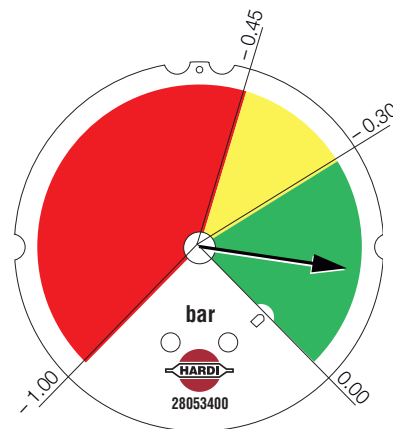

EasyClean Vacuum Gauge

Self-cleaning pressure filter with return line to tank

Blue line: Suction, Red line: Pressure, Green line: Return

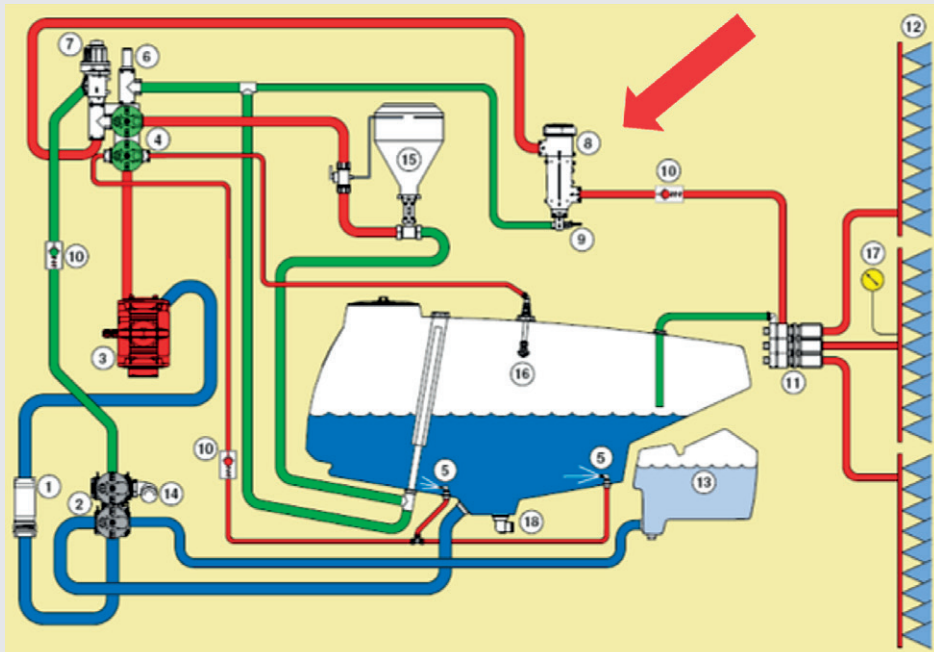

Pressure filters

Pressure filters are placed after the pump and they have a higher degree of filtration as their task is to prevent damage to the controls and nozzle blockage.

The classic pressure filter is a bowl-type filter where the base is removed to service the filter. There is often a risk of spot pollution with this type of filter as the bowl is full of liquid.

Modern pressure filters are self-cleaning. The residues are continually washed away preventing the filter blockage. The principle can be compared to a river where the banks are very wide and then narrow. At the wide banks, the water flow is slow and little erosion occurs at the banks; the banks are sandy. As the river narrows, the flow increases in speed and the banks erode (wash away) leaving only solid stone as all the sand has been washed away. The change in water flow velocity is the principle behind a self-cleaning filter. The return-to-tank line removes the particles from inside the filter.

The HARDI Self-cleaning filter from 1982 was the first of this type.



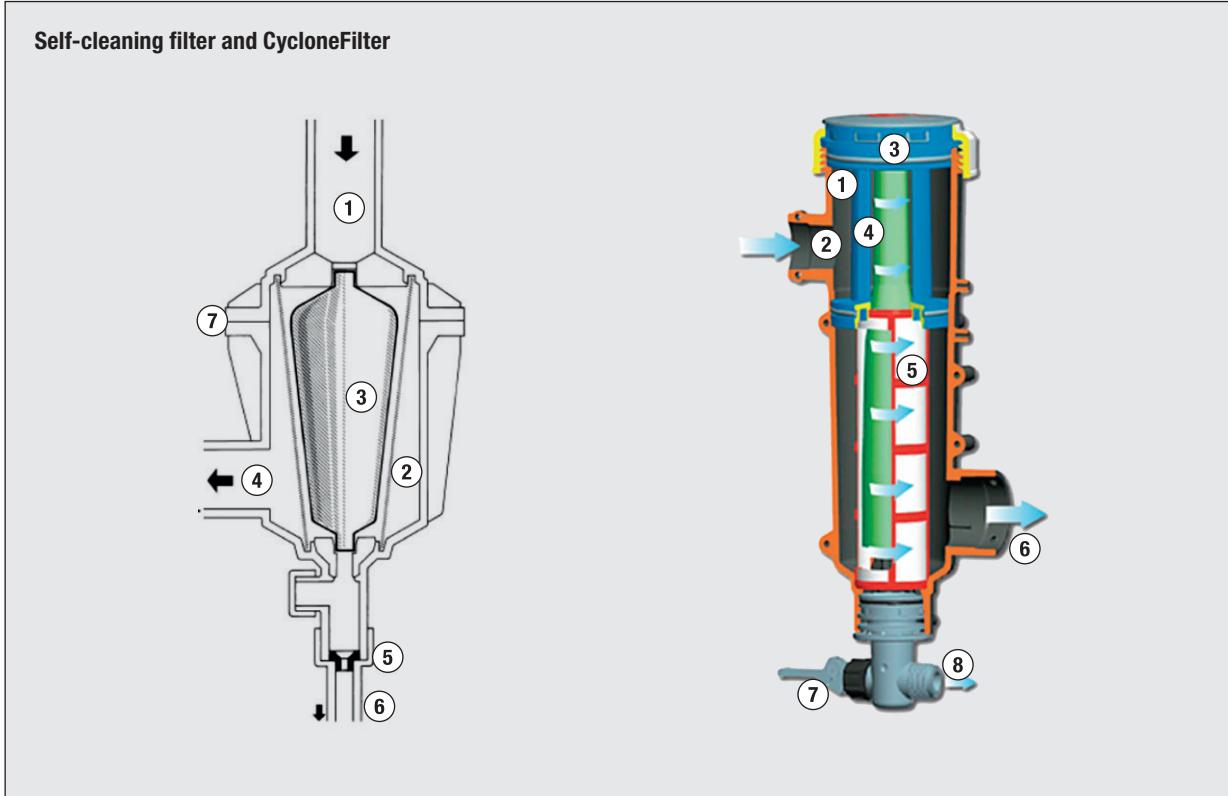

Self-cleaning filter and CycloneFilter

The HARDI Self-cleaning filter has a solid cone **(3)** inside the filter mesh that is narrow at the liquid exit area. This is what causes the flow to increase in speed and maintain a self-cleaning action. The restrictor **(5)** on the return to tank **(6)** maintains pressure in the system. If the restrictor is missing, the sprayer will not be able to achieve working pressure.

The HARDI CycloneFilter is also a self-cleaning filter and it has a valve at the base instead of a restrictor. It was first introduced on the COMMANDER in 2005 to handle the higher capacity requirements.

The valve **(7)** has 3 different positions:

- ▶ **A.** Self-cleaning OFF: Used during cleaning process
- ▶ **B.** Self-cleaning ON: Normal position. Large particles return to the main tank
- ▶ **C.** Boost: Used for extra filter flush during cleaning

Furthermore, the cleaning capacity is enhanced by creating a cyclone effect in the liquid flow by winglets **(4)** at the liquid entrance.

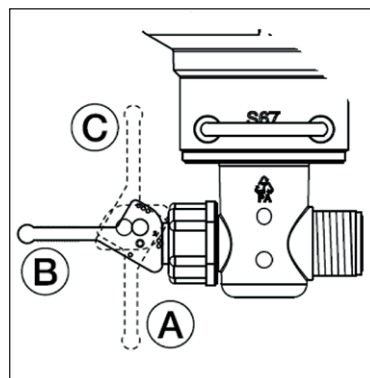

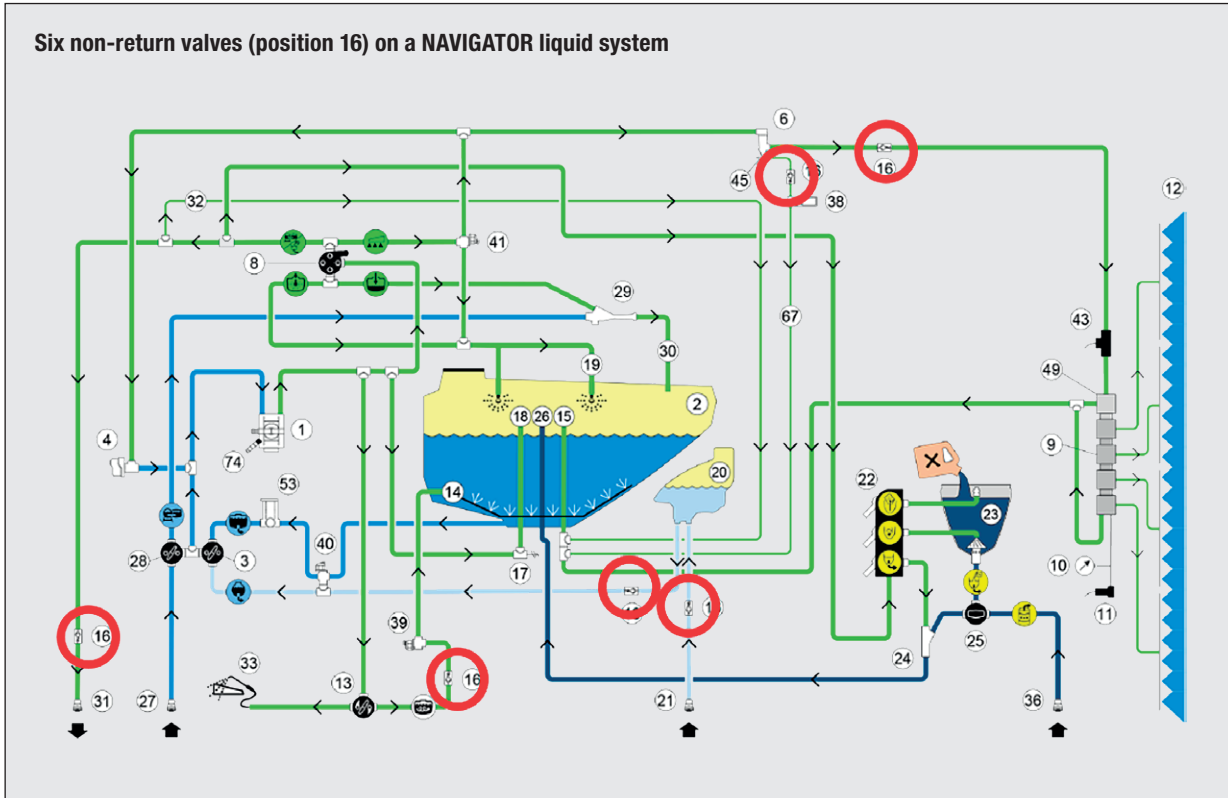

Non-return valves

A non-return valve only allows flow in one direction. The cone (4) is fitted with an O-ring seal that closes on a stainless steel seat (5).

Smaller non-return valves may utilise a stainless steel ball closing on a synthetic seat.

Poor cleaning can be responsible for failure in non-return valves as residues can damage the seal and/or cause it to stick.

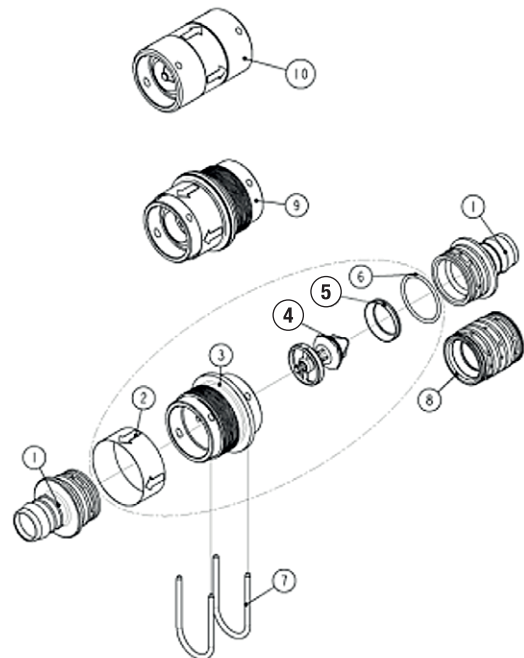
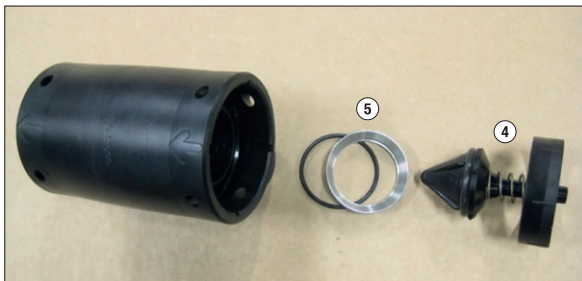



CHAPTER 4

FastFiller, safety and SmartValves

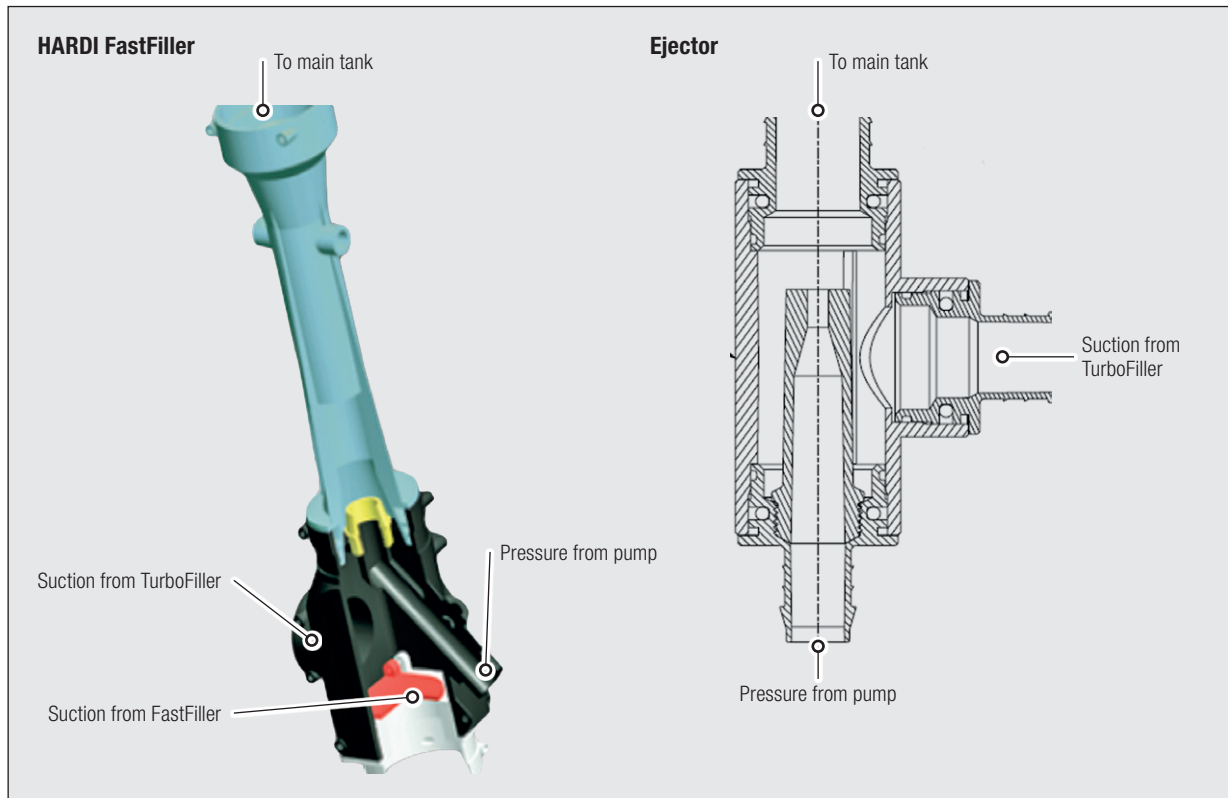

FastFiller and Ejector

The HARDI FastFiller is a filling device using a venturi system. This creates a vacuum for increasing the filling capacity. The pump capacity is more than doubled with this device. The ejector is a smaller version used with some TurboFillers.

A Model 463H (high capacity) pump at 540 r/min produces 322 l/min (85 US gpm). The filling capacity rises to 800 l/min (211 US gpm) when filling from ground level through a 2½" hose.

If the system is dry, the diaphragm pump will prime the filling device so the venturi effect can be started. A valve inside the FastFiller prevents liquid to return to the filling source.

The colour-coded restrictor inside the tube is matched to the pump capacity. Higher capacity requires a larger restrictor orifice. The model 460 series of pumps uses the yellow restrictor.

The tank must be fitted with a high capacity air vent otherwise this will reduce filling rate.

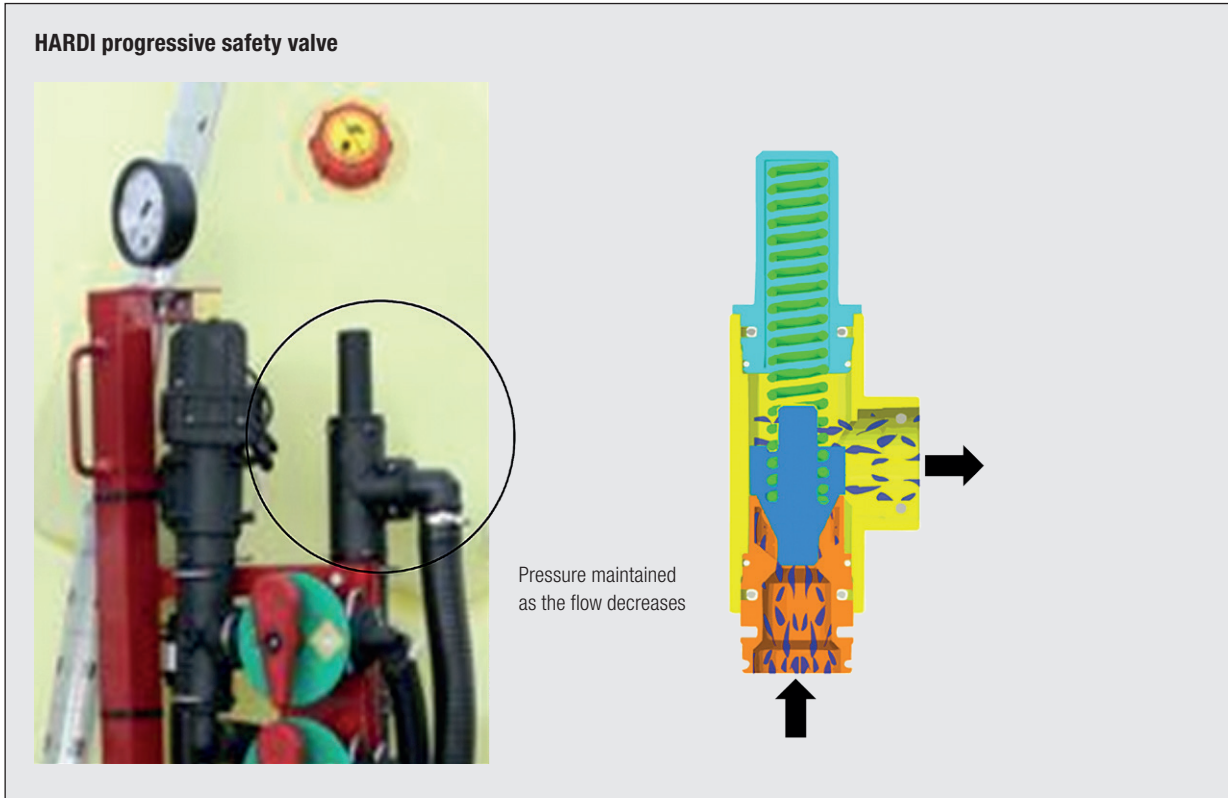

Safety valve

The pressure safety valve protects the liquid system from excessive pressure. If the system exceeds a pre-set maximum pressure, the valve will open and the liquid will be returned to tank. Without the safety valve, hoses or fittings would be damaged.

For HARDI field sprayers, the maximum pressure is set at 15 bar (220 psi). Typical spraying pressure is between 1.5 bar (20 psi) to 5 bar (70 psi). Optional equipment like the pesticide transfer systems, tank flush nozzles etc. often perform best at higher pressure and therefore the maximum pressure choice at the safety valve. For HARDI orchard sprayers, the maximum pressure is set at 25 bar (360 psi) as these

sprayers typically use hollow cone nozzles that operate best at higher pressures.

A simple safety valve opens at the pre-set pressure and will typically remain open until the pressure drops to about the half. This type of valve is used on basic sprayers like the HARDI NK that has the safety valve built into the control unit.

A progressive safety valve opens at the pre-set pressure and progressively closes as the pressure drops. It maintains the pre-set pressure. This is advantageous for some optional equipment where the high pressure is required. The HARDI progressive safety valve is used on most of the medium to high-end HARDI sprayers.

Manifold valves and SmartValves



Manifold and SmartValves

The simpler the sprayer is, the easier it is to use it correctly.

HARDI Manifold valves group the suction and pressure valves in two manifolds. The pressure manifold is connected to the safety valve.

HARDI SmartValves combine a number of functions in the one valve handle. Operation of the one valve handle opens and closes a number of ports. Full operation is generally possible with two SmartValves, being suction line and pressure line and one or two other valves.

Colour coding and icons are used to ease identification of the function.

- ▶ **Blue** is the suction side
- ▶ **Green** is the pressure side.
This may include low pressure return lines
- ▶ **Yellow** for product transfer equipment



CHAPTER 5

Function diagram for liquid system

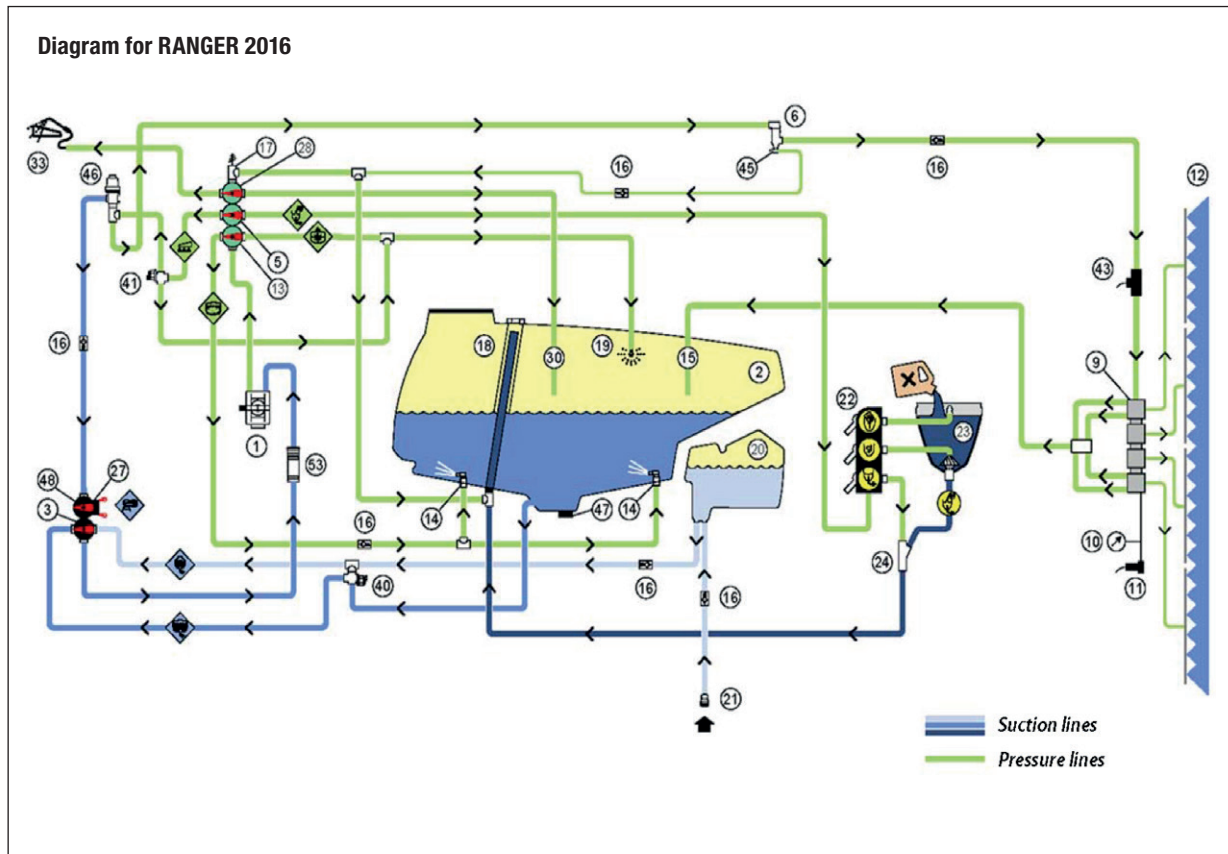

Functions overview

The HARDI sprayer instruction book always shows a diagram for the sprayer liquid system. It shows the colour-coded icons physically found on the sprayer. This diagram is to help understand the spray functions and cleaning of the sprayer.

It is also an invaluable tool for fault-finding on the sprayer because if you understand the system, you should be able to find the problem in minimal time.



CHAPTER 6

Nozzles

Pesticide label stating dosage and application rates

Dosering

Hvede 0,2–1,0 l pr. ha
 Vinterrug 0,2–1,0 l pr. ha
 Triticale 0,2–1,0 l pr. ha
 Byg 0,2–1,0 l pr. ha
 Havre 0,2–1,0 l pr. ha
 Frøgræs 0,5–1,0 l pr. ha
 Raps 0,5–1,0 l pr. ha

Der benyttes 150–300 l/ha.

Folicur kan f.eks. udbringes med medium forstøvning:

Dyse	Tryk	Hastighed	Vandmængde
ISO 110-025 (lilla)*	2,6 bar	7,5 km/t	150 l/ha
ISO 110-03 (blå)*	2,8 bar	7,0 km/t	200 l/ha

*Under normale sprøjteforhold kan fladsprededyser anbefales. Ved behov kan skiftes til tilsvarende LowDriftdyser.

Pesticide dosage

Application rate

Recommended

Understanding the application task

Before choosing a suitable nozzle for a particular spray task, we need to understand the choices the operator has to make before choosing a nozzle.

A typical agricultural pesticide label states pesticide dosage, water application rate and maybe some recommended choices.

Pesticide dosage

The three main pesticide groups are herbicides for weeds, fungicides for fungi and insecticides against insect pests. The pesticide dosage is the amount of pesticide needed for a given area (hectare or acre) for a particular crop. The dosage may have a minimum and maximum value. The amount used

depends on crop and pest stage, weather conditions and application technique. The lower recommendations will be chosen under ideal conditions.

Application rate

This is the amount of water to be applied with the pesticide for a given area. It will also have a recommended minimum and maximum value. A tall crop will typically require higher rates than a short crop. The operator will tend to choose the lower rates as this improves his spraying capacity.

Once the application rate has been established, weather conditions are the next factor to consider before choosing the best nozzle for the application task.

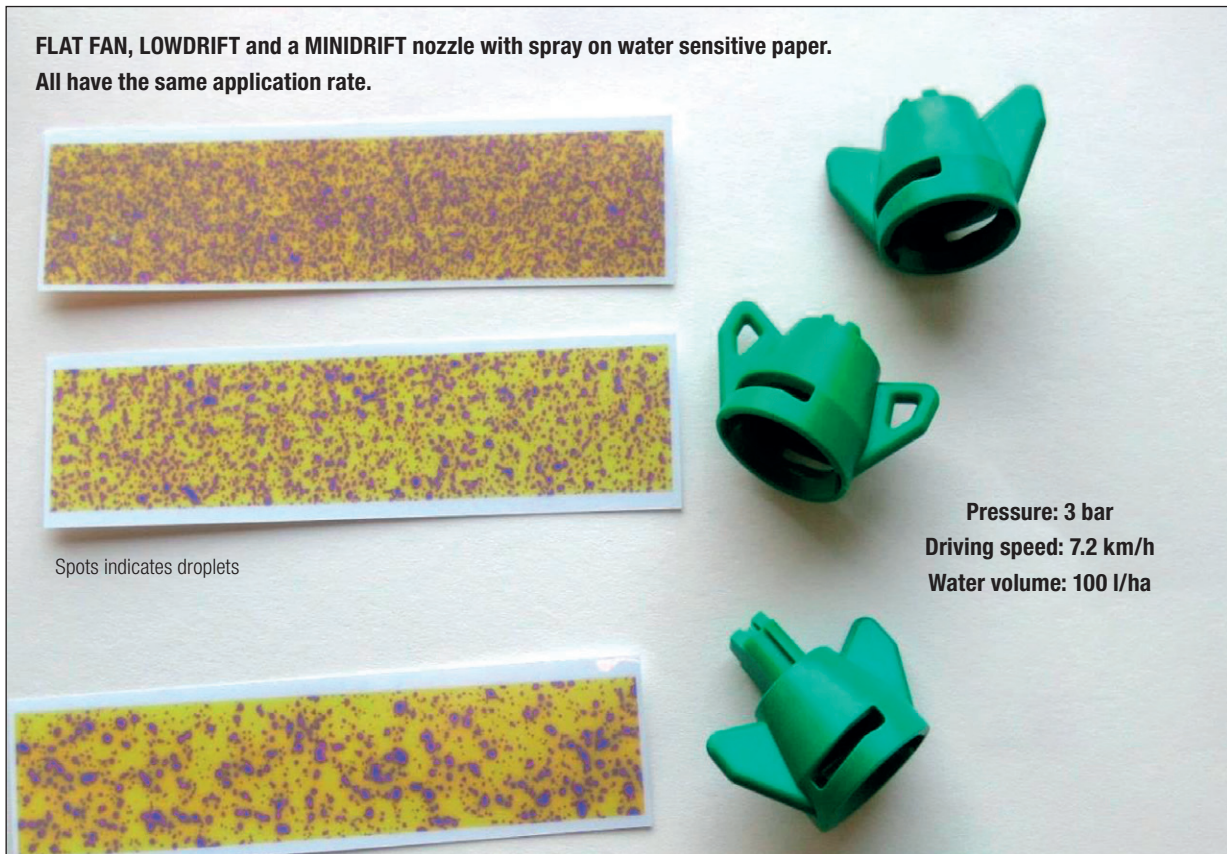

Four basic nozzle types

For broad-acre field sprayers with 50 cm (20") nozzle spacing, the tapered flat fan nozzle is usually the best choice. It should have the following features:

- ▶ Colour-coded to ease identification
- ▶ Follow ISO standards on size, colour and nozzle type codes
- ▶ A spray angle of about 110° for double overlap for good distribution
- ▶ A snap fit holder to secure the correct offset angle
- ▶ High accuracy
- ▶ Be made of long wearing material
- ▶ Be reasonably priced

There are 4 basic flat fan nozzle types:

- ▶ Standard FLAT FAN nozzle (FF)
- ▶ LOWDRIFT fan nozzle (LD)
- ▶ MINIDRIFT air induction fan nozzle (MD)
- ▶ INJET air induction fan nozzle (I)

The standard FLAT FAN (FF) usually has the best efficacy. As we move down this list, the droplet size increases to reduce spray drift for spraying done in windy conditions. The payoff is efficacy. The bigger the drops, the more we lose to the ground.

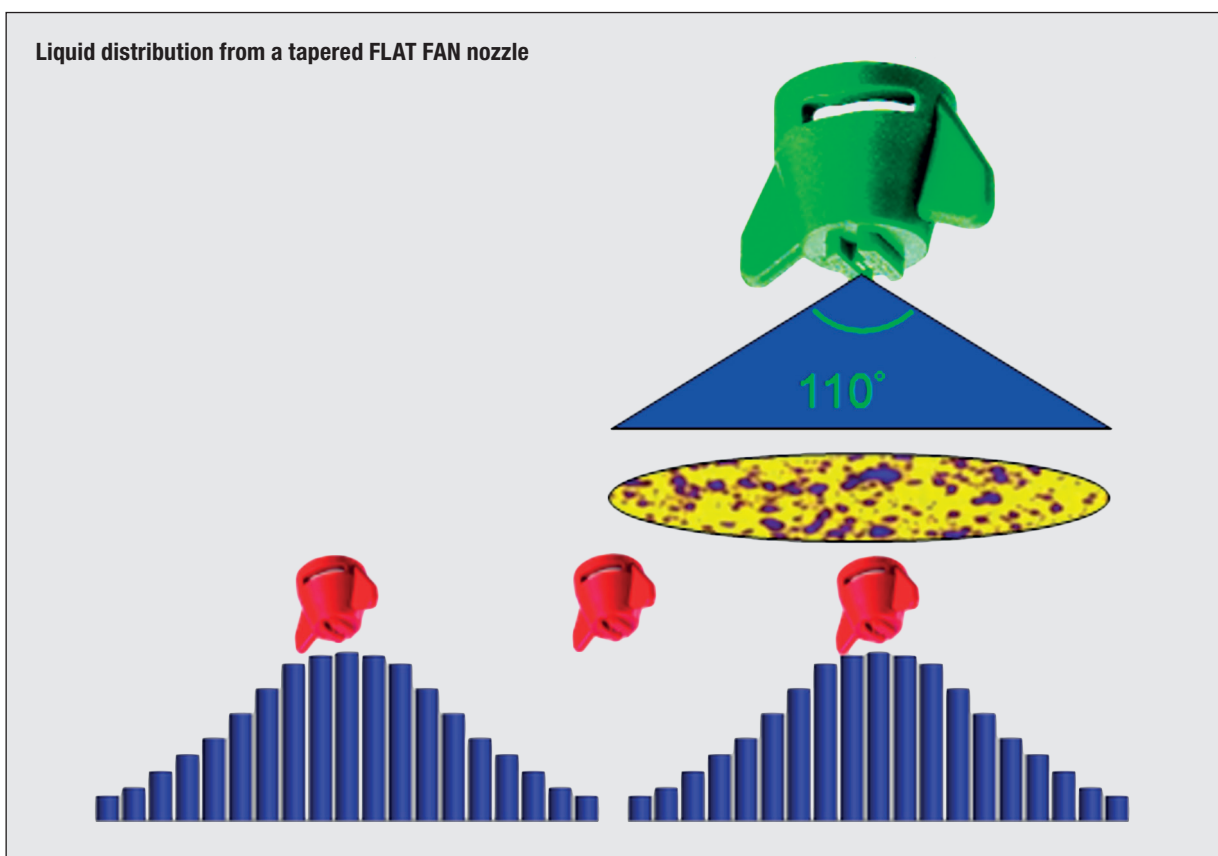

Tapered FLAT FAN nozzle distribution

The FLAT FAN nozzle used on field sprayers has a tapered liquid distribution. More liquid is sprayed out directly under the nozzle compared to the edges. If every second nozzle was turned off, the collected liquid would look as above. The neighbouring nozzle has the same pattern and by overlapping the spray, the final result is an even distribution of the liquid.

This can also be done with nozzles with an even distribution where the liquid sprayed out is evenly distributed under the nozzle, i.e. the same amount under the nozzle as at the edges. When used on a boom, this is not practical as it is extremely difficult to maintain an even distribution as it requires the boom to stay at exactly the same height.

The tapered flat fan nozzle is better suited to distribute the liquid more evenly even at varying boom heights.

ISO chart

Flow		Colour	Number	Type
3 bar l/min	40 psi US gpm			
0,3	0,075	Pink	0075	FF
0,4	0,1	Orange	01	FF, LD, I
0,6	0,15	Green	015	FF, LD, MD, I, Q
0,8	0,2	Yellow	02	FF, LD, MD, MDD, I, Q
1,0	0,25	Lilac	025	FF, LD, MD, MDD, I
1,2	0,3	Blue	03	FF, LD, MD, MDD, I, Q
1,6	0,4	Red	04	FF, LD, MD, MDD, I, Q
2,0	0,5	Brown	05	FF, LD, MD, MDD, I, Q
2,4	0,6	Grey	06	FF, I, Q
3,2	0,8	White	08	FF, I, Q
4,0	1,0	Light blue	10	FF, Q
6,0	1,5	Light green	15	Q

Range of HARDI ISO nozzles

The above table shows the flow, colour, identification number and type of nozzles in the HARDI range.

- ▶ FF is FLAT FAN
- ▶ LD is LOWDRIFT
- ▶ MD is MINIDRIFT,
- ▶ MDD is MINIDRIFT DUO,
- ▶ I is INJET
- ▶ Q is QUINTASTREAM

The numbering system origins from US flow units. The flow at 40 psi can be read directly from the number.

Example: Size 01, orange nozzle gives 0.1 US gpm at 40 psi.

When using metric units, the nozzle number multiplied by 0.4 gives the flow at 3 bar pressure.

Example: Size 01 orange, $1 \times 0.4 = 0.4$ l/min at 3 bar pressure.

The relation between number and flow is a handy feature. If the nozzle number is doubled then the flow will also be doubled.

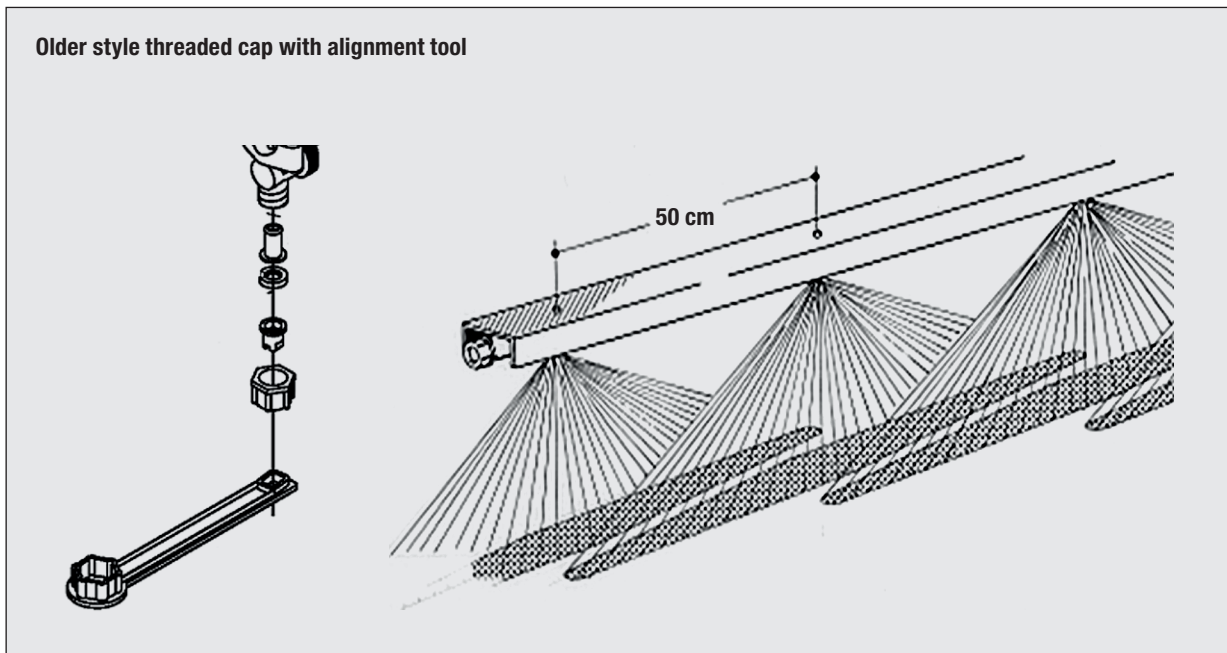

Nozzle offset angle

The nozzles used on a boom should have an “offset” angle of 8 to 9° to the boom. This is to avoid the nozzle spray swath spraying into the neighbouring swaths causing swath reduction and formation of courser droplets.

If the sprayer is mounted with SNAP-FIT caps, then the angle is automatically built into the cap.

If the sprayer has the old $\frac{3}{8}$ ” screw caps, the angle has to be adjusted manually. A “HARDI pipe” tool (Ref. No. 333174) was supplied with this system to assist setting the correct angle.



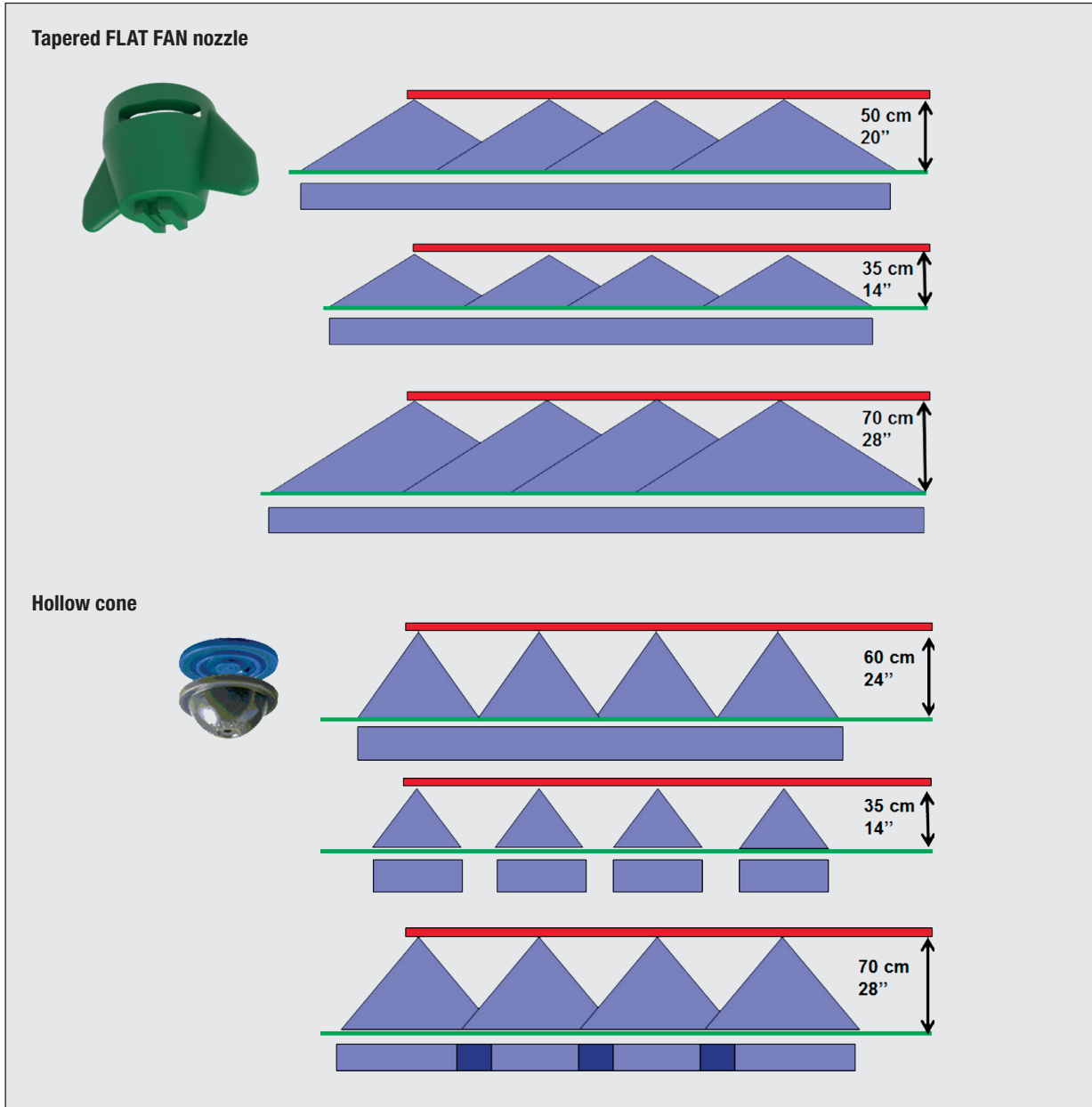

Nozzle to target distance

The optimal boom height (nozzle to target distance) is 50 cm (20"). Actually HARDI 110° nozzles can be used from 35 to 70 cm (14 to 28"). The lower height reduces the risk of spray drift but it can be difficult to accurately maintain the low height. Keeping the boom high to avoid ground strikes will increase spray drift. Spray drift can increase by 20 fold if spraying at 100 cm (40") boom height. Therefore, we advise to set the boom to 50 cm (20") to allow for terrain and boom movements.

The even spray or hollow cone nozzles need exactly correct distance from nozzle to target. A low boom will lead to missed strips and a high boom will lead to double application. This is why they are not used on broad-acre boom sprayers.

Droplet diameter and numbers relation

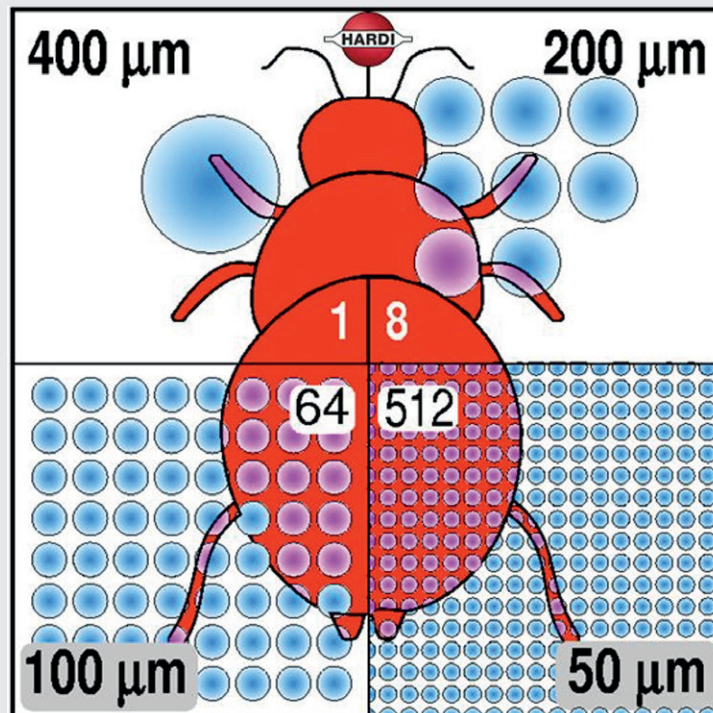

Droplet volume, diameter and coverage

The same volume of liquid atomised in different droplet sizes gives a very big difference in coverage.

If the diameter is halved, the result is approximately 8 times more droplets and the potential for coverage is thereby greatly increased.

There is not a perfect drop size for spraying. A range of droplet sizes is usually best. The droplets can also be too big and too small. Relatively big drops are less susceptible to drift and better at penetrating a crop but may often end up on the ground. Small drops remain on the leaf and give better coverage but are susceptible to wind drift and loss to evaporation.

The best nozzle to use in good spraying conditions is the standard FLAT FAN (FF) nozzle. It has the best efficacy and lower rates of water and pesticide may be possible. The other nozzle types can be chosen when conditions are not ideal. The negative side is that the efficacy is reduced and therefore it becomes more risky to reduce rates.

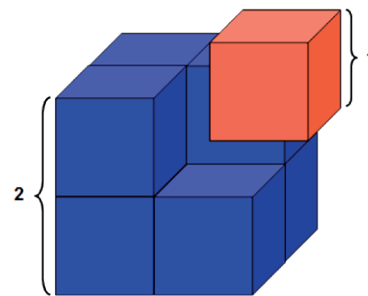

Water Sensitive paper and nozzle types
3.6 bar, 150 l/ha, 7 km/h

HARDI INJET nozzles
INJET-02-110

HARDI MINIDRIFT nozzles
MINIDRIFT-02-110

HARDI LOWDRIFT nozzles
LD-02-110

HARDI FLAT FAN nozzles
F-02-110

HARDI FLAT FAN nozzles + TWIN
F-02-110 + TWIN

Droplet volume, diameter and coverage

Water Sensitive Paper turns blue when droplets come in contact with it. It is an easy way to do a relative evaluation of droplet size, spray pattern and crop penetration. The above picture indicates the droplet size from different nozzle types.

If spraying in windy conditions, the nozzles producing larger droplets are preferred. This could be a LOWDRIFT, MINIDRIFT or a INJET nozzle.

The smallest droplets give the best coverage and under ideal conditions nozzles producing small droplets are preferred. Here the FLAT FAN is the best choice.

A combination of FLAT FAN nozzles and the TWIN system increases coverage even more. The TWIN system produces a curtain of air just behind the nozzle which pushes the droplets into the canopy. This reduces drift, increases coverage and allows the spraying to be done in otherwise unfavourable (windy) conditions. Under very windy conditions, LOWDRIFT nozzles can also be used with the TWIN system.

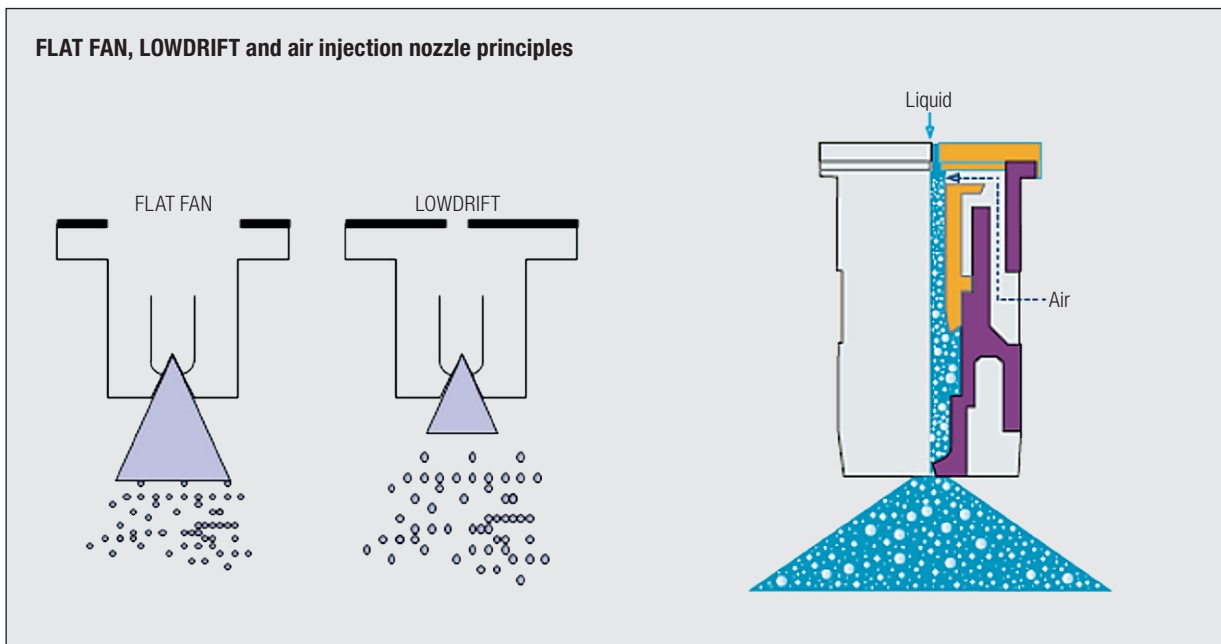

Drift reducing nozzles

The LOWDRIFT, MINIDRIFT and INJET can be used to reduce spray drift.

Design technique is used to reduce the spray veil length and when the veil breaks, the droplets formed are larger.

The LOWDRIFT uses a restrictor to meter the flow and the opening to form the pattern.

The MINIDRIFT and INJET use an air injection principle to produce large droplets.

Compared to the LOWDRIFT and MINIDRIFT, the INJET nozzle is physically longer and needs to operate at higher pressures.



	INJET	MINIDRIFT
Pressure range	3 to 8 bar (45 to 116 psi)	1.5 to 6 bar (22 to 88 psi)
Droplet size	Always very coarse	Very coarse up to 2 bar (28 psi)
Needed size with relation to capacity	Smaller than MD and FF	Same size as MD and FF

Dribble hoses



3-hole nozzle



QUINTATREAM fertiliser nozzles

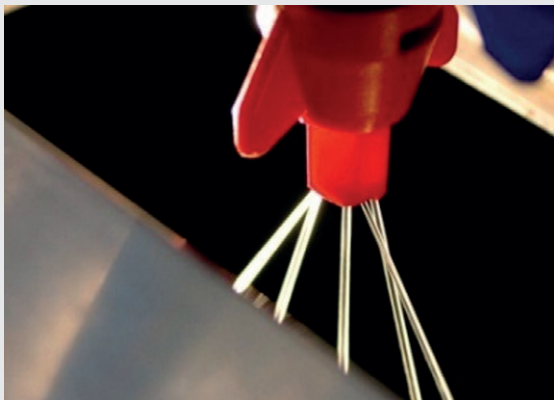

QUINTATREAM fertiliser nozzles

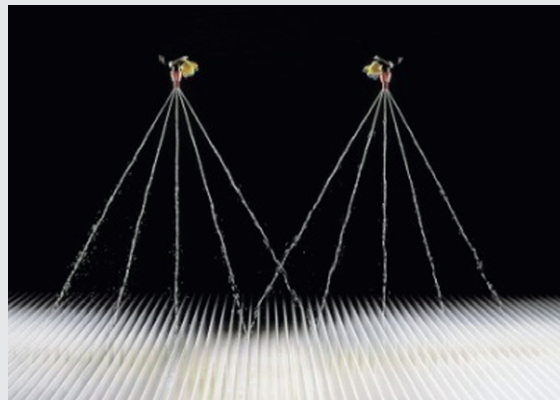

Fertiliser nozzles

Soluble fertilisers can be applied with sprayers. This application method offers a more accurate distribution of the fertiliser. Foliar fertilisers are applied to the crop canopy and a normal FLAT FAN nozzle is best for this job. Other fertilisers may scorch the foliage if applied to the canopy and therefore dribble hoses or specialised nozzles are used to keep the spray off the foliage.

Dribble hoses

These are usually fitted to the boom with 25 cm (10") spacing and, via a restrictor at the nozzle body, meter the liquid. This is complex to attach to the boom, adds weight and can clutter the boom. It is now not popular as better alternatives exist.

3 or 4-hole nozzles

These types of nozzles produce three or four solid streams of liquid. This is much easier to apply and does not clutter the boom. Correct boom height is necessary for an even distribution.

QUINTASTREAM

This HARDI nozzle produces five solid streams of liquid at different flow rates. The application is overlapped which gives a more uniform distribution ranging from 35 cm (14") to 100 cm (39") boom height.

Hollow cone nozzle, pneumatic nozzle and adjustable nozzle

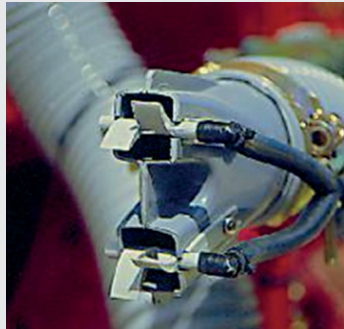

Nozzles for orchard sprayers and mistblowers

Orchard sprayers and mistblowers utilise various nozzle types. There are 4 basic application groups:

- ▶ The ceramic hollow cone nozzle is the most used because of higher spraying pressures, 10 to 30 bar (140 to 450 psi), and the use of many powder type pesticides. This nozzle type is typically used on a blower turbine.
- ▶ The FLAT FAN nozzles as known on boom sprayers can be used on a turbine.
- ▶ Pneumatic nozzles are used on some sprayers e.g. for vineyards. The droplets are formed by an air shear technique and hoses with spouts can guide the air and spray more precisely to the target. Restrictor nozzles are used to meter the flow and the pressures are usually low, between 1 to 3 bar (14 to 45 psi).
- ▶ Adjustable nozzles are used but to a lesser extent. They tend to produce relatively large drops. When re-adjusted, the sprayer needs to be recalibrated.

Special nozzles



Boom end nozzles



Hand operated sprayers



Calibration disks,
Solid stream,
Hollow cone



Narrow angle



Fertiliser



Moisturising



Tank cleaning
& agitation

Specialised nozzles

HARDI supplies a wide range of special nozzles. Here are some examples:

Boom end nozzles extend the width of the boom

This can be advantageous to avoid spraying too close to obstacles (e.g. fences) but the distribution is typically poorer than the nozzles under the boom.

Hollow cone and solid stream nozzles for orchard and vine applications

They have a round orifice and are typically less prone to blockage.

Nozzles for hand operated sprayers

The operator supplies the pump energy and is at a higher risk of contamination. Therefore, low pressure (low energy) and wide angles (less drift) are most favoured.

Nozzles for agitation and cleaning

Nozzles used to agitate liquid can double or triple the liquid movement in the tank by use of a venturi effect. The holes around the orifice allow the passive liquid to be drawn into the flow.

Nozzle material

Material	Flow increase after 40 hours wear
Brass, Teejet	11.4%
Zytel (synthetic), Delavan	7.5%
Stainless steel, Teejet	6.1%
Kemetal (synthetic), Lurmark	2.1
Hardened Stainless steel, Teejet	1.2%
SYNTAL (synthetic), HARDI	0.4%

University of Illinois

Nozzle materials and wear rate

It is a fact that some synthetic materials used in the production of nozzles have a longer life than metallic materials. Independent tests of nozzle wear confirm this. Results in the above table from the University of Illinois are an accelerated wear test where an abrasive material, like silica, is added to the liquid and all nozzles are tested simultaneously.

Compared to metallic materials, synthetic materials are more “elastic” and do not erode as easily as metal. Therefore, they have a longer life.

Ceramic nozzles have a very long life. A good quality ceramic disc for a hollow cone nozzle (round orifice) is relatively easy to produce even for low capacity nozzles.

A good quality, low capacity FLAT FAN ceramic nozzle is relatively difficult to produce. The orifice is elliptical and the production methods, e.g. cooling of the material, make production of good quality of small capacity nozzles difficult.

At HARDI, our nozzle production is tested every 2 hours.

HARDI Nozzle calculator disc, metric and US version

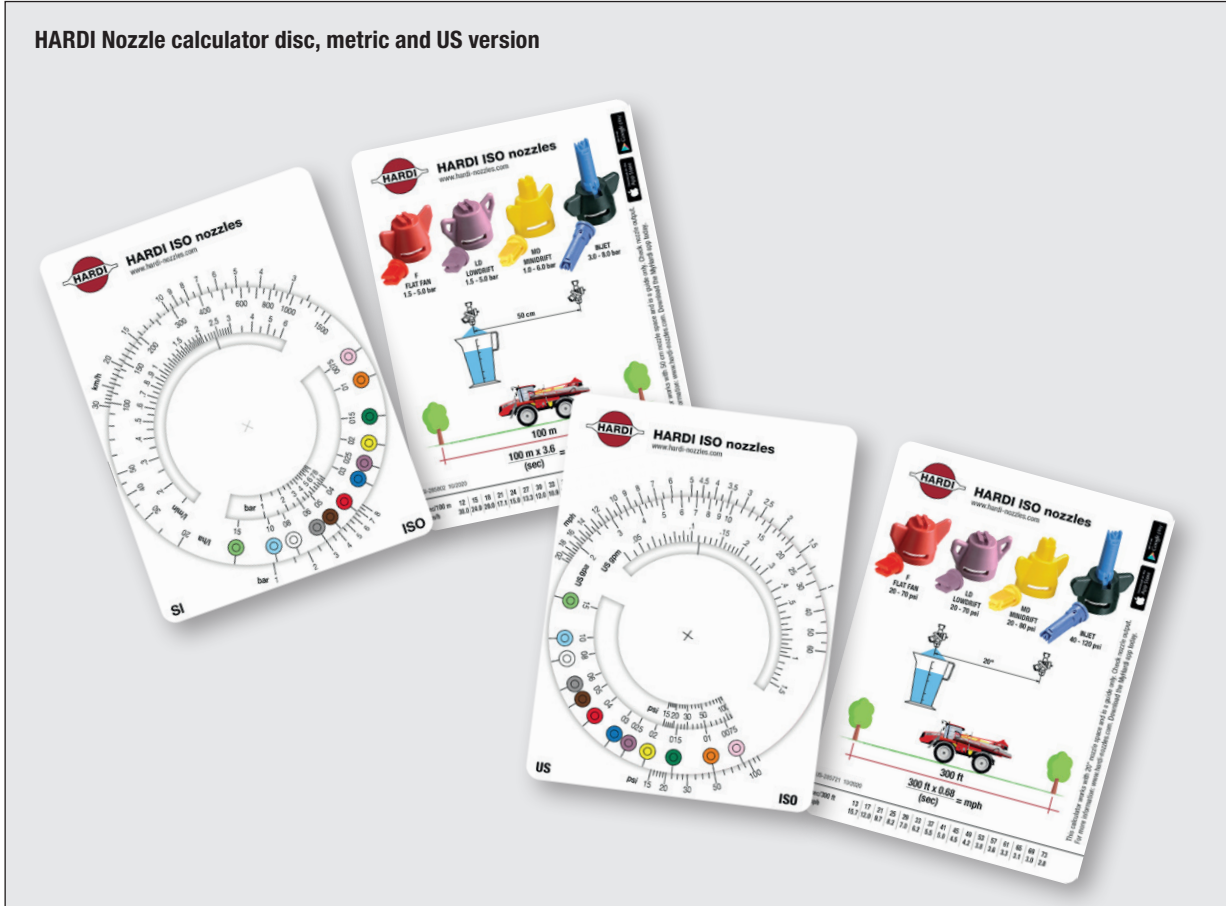

Calibration

There are 4 steps:

- 1 Check driving speed
- 2 Calculate required nozzle flow
- 3 Choose nozzle size
- 4 Check nozzle output

You need to:

- ▶ Measure a distance of about 100 metre (300 feet)
- ▶ Have a good quality measuring jug of about 2 litres (70 US fl. oz.)

Calibration disk

Example with metric version:

Verified speed: 9 km/h

Application rate: 120 l/ha

Align speed, (9 km/h; top scale on rectangular part) with application rate (120 l/ha; top scale on round disc). Now you can read off flow rate per nozzle (0.9 l/min; window in disk).

On the lower scale, the ISO nozzles are aligned with the appropriate pressure. Nozzles within the 1.5 bar (20 psi) to 5 bar (70 psi) range are the preferred choice.

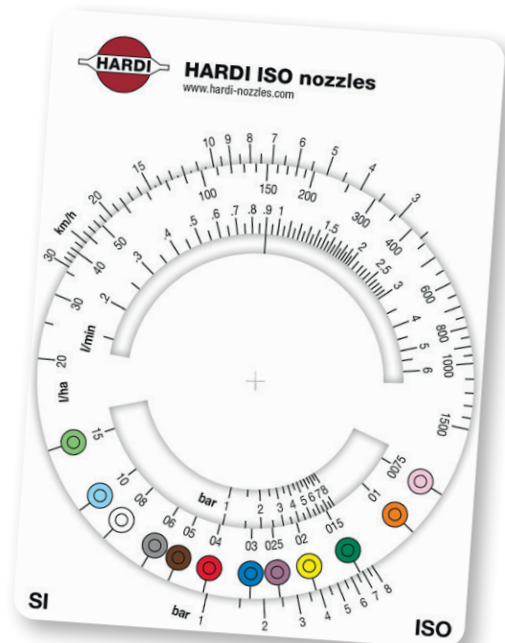

The online HARDI Nozzle Selector – app or website



Calibration online

An online HARDI nozzle selector is also freely available for use on smart phones and PCs.

The online HARDI Nozzle Selector or the HARDI Nozzle calculator disc makes calibration easier. They both offer an easier way to calibrate than the old style nozzle tables.

MyHARDI

All your information in one place.

With MyHARDI you are able to connect with your sprayer, find your instruction books, watch our instruction videos, download the latest brochures, check your local weather forecast and get in touch with your dealer. And of course select your nozzles.

You can find MyHARDI here:

- ▶ Visit the website **myhardi.com**
- ▶ Download the **myhardi app** from your App Store.

The sprayers are delivered with a “Spray Technique” manual and this is also a good reference.

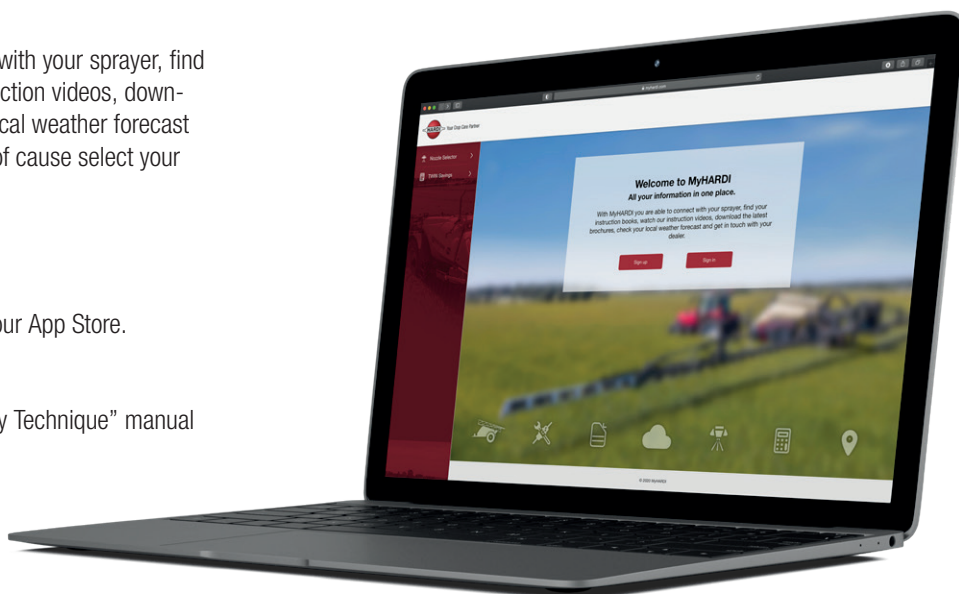





CHAPTER 7

Hydraulics

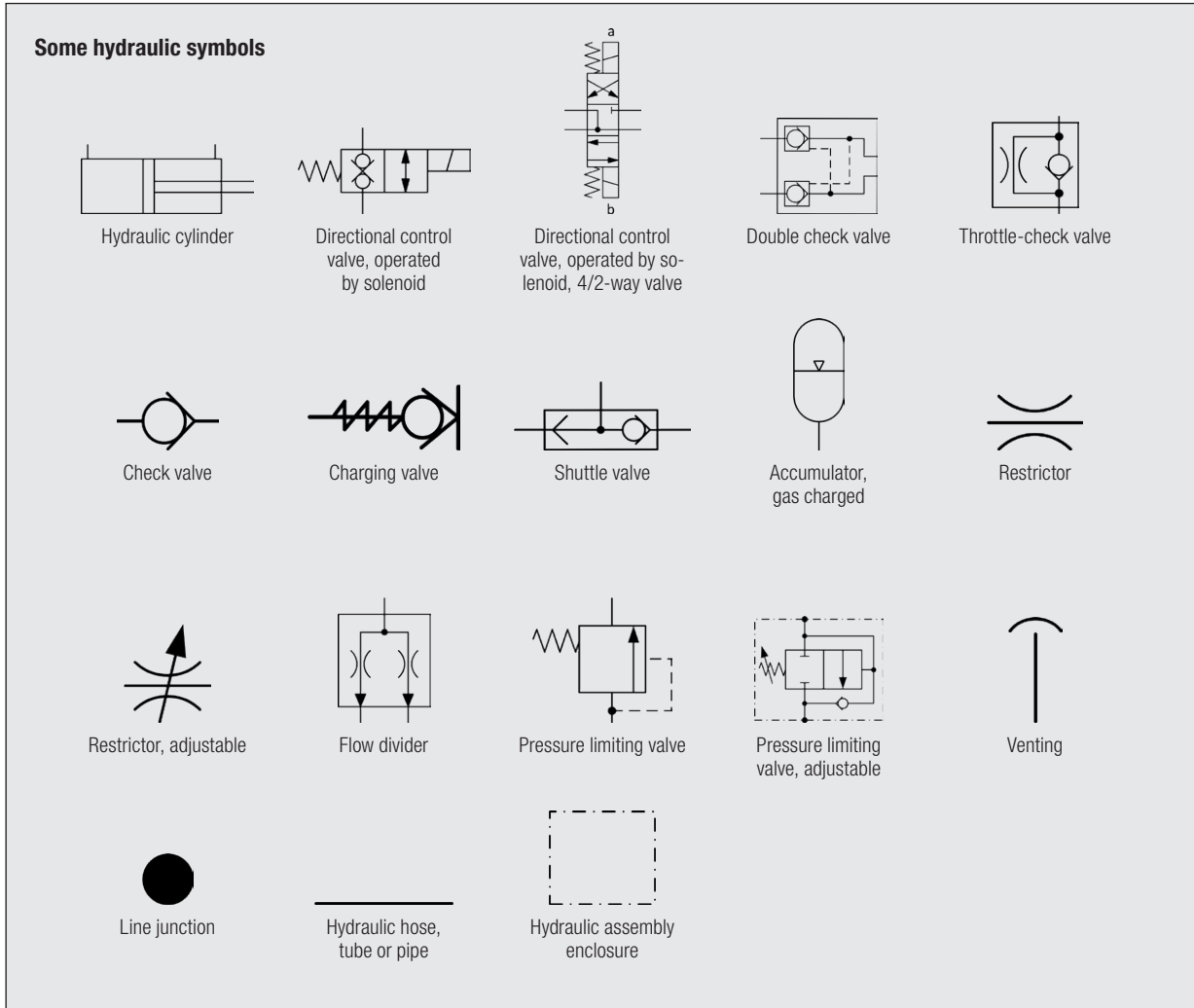

Symbols

Hydraulic symbols are the language used to help us understand the principles of a hydraulic system. If we need to do trouble-shooting on a system, then we need to understand it. A hydraulic diagram with hydraulic symbols can give us this understanding.

Initially, it takes time to understand the symbols but after a while, it becomes easier and easier to remember them and understand the systems.

When physically working with hydraulic systems, there are three golden rules:

- ▶ Cleanliness
- ▶ Always wear gloves
- ▶ Never remove safety valves

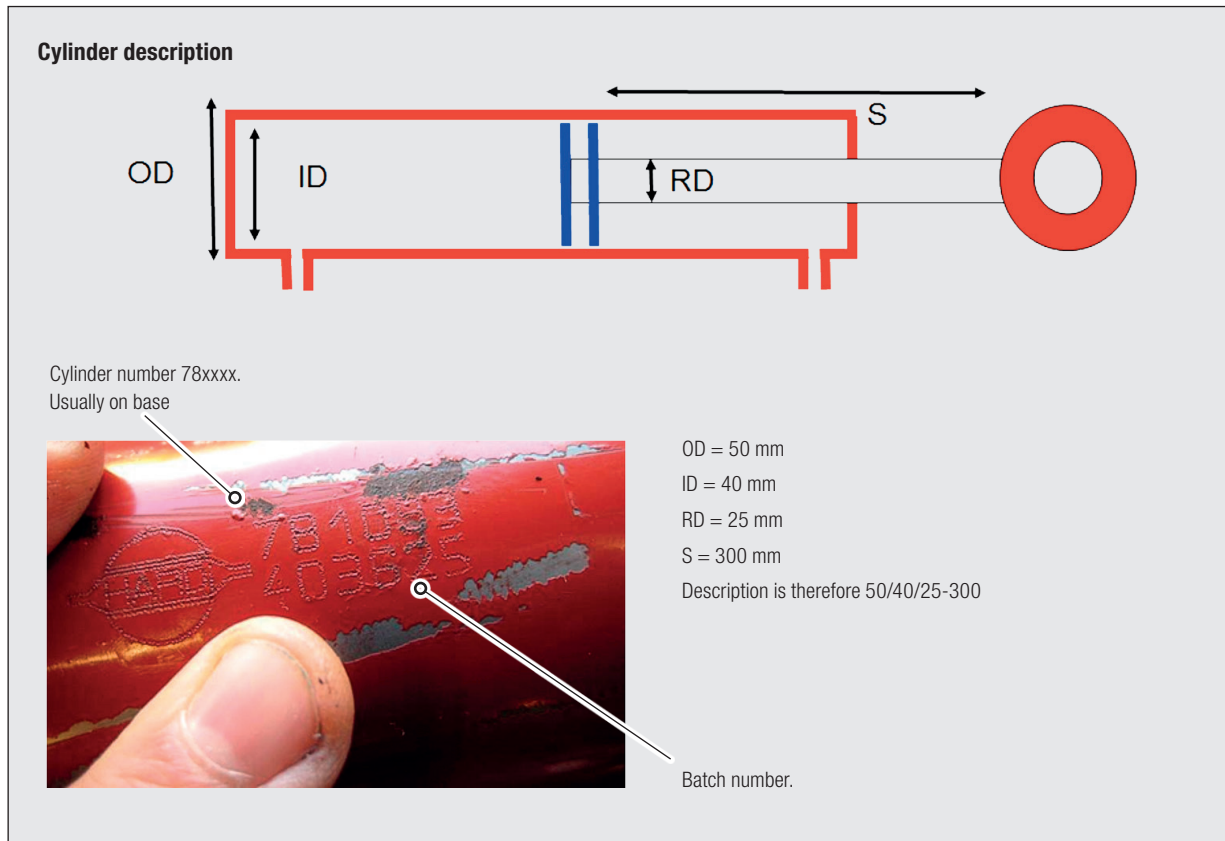

Cylinders and seals for hydraulic fittings

The cylinder reference number is handy if you need to order a seal kit. With the correct cylinder reference, a cross reference to the correct seal kit is available in the spare parts information.

If no reference number is found, measure the outer diameter of the cylinder, then subtract 2 x 5 mm, as the HARDI cylinder wall is typically 5 mm, to obtain the inner diameter of the cylinder. Now measure the outer diameter of the rod or the stages of a telescopic unit. The last value is the stroke length in millimetres.

The HARDI reference number of most hydraulic cylinders starts with the digits 78 followed by 4 or 6 digits.

The HARDI reference number of most pre-packed seal kits starts with the digits 75 followed by 4 or 6 digits.

Up until 2012, the seals for hydraulic fittings were of the tapered type. From 2012, the seals were changed to the ORFS (picture insert is O-Ring Face Seal). The new fittings cannot be fitted to the old fittings. The flat face fittings are fitted with an O-ring to ensure an easier and better seal.



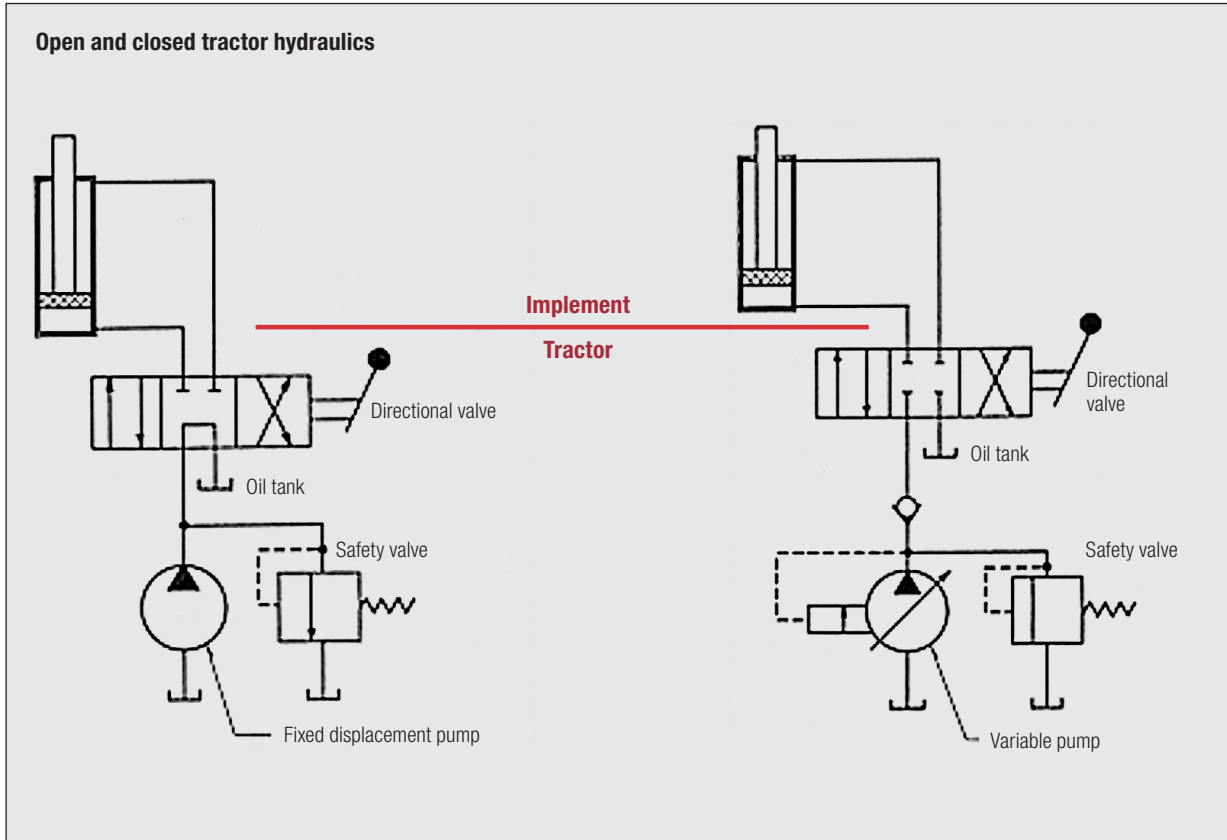

Open and closed centre tractor hydraulics

Some tractors produce a constant flow of oil for the implements and other tractors only produce the amount needed. These systems are called open and closed centre hydraulics respectively.

Open centre

The tractor oil pump produces a constant and continuous flow that returns to tank when implement has no oil usage. Activating a function on the implement closes the oil return to tank and causes the pressure to rise and function to be activated. The oil pump safety valve dumps oil once the flow to the implement stops. Typical maximum pressure values are from 195 to 210 bar (2800 to 3000 psi)

Closed centre

The tractor oil pump is variable and only produces a flow when the implement function is activated. Activating a function on the implement causes the pump to produce more flow until the pressure activates the implement function.

Open centre tractors need a by-pass on the sprayer. If this is not present, the oil will be at high pressure and re-circulate via the tractor safety valve which in the end may cause the oil to overheat.

Simple lever controlled “Y” and electro-hydraulically controlled “Z”

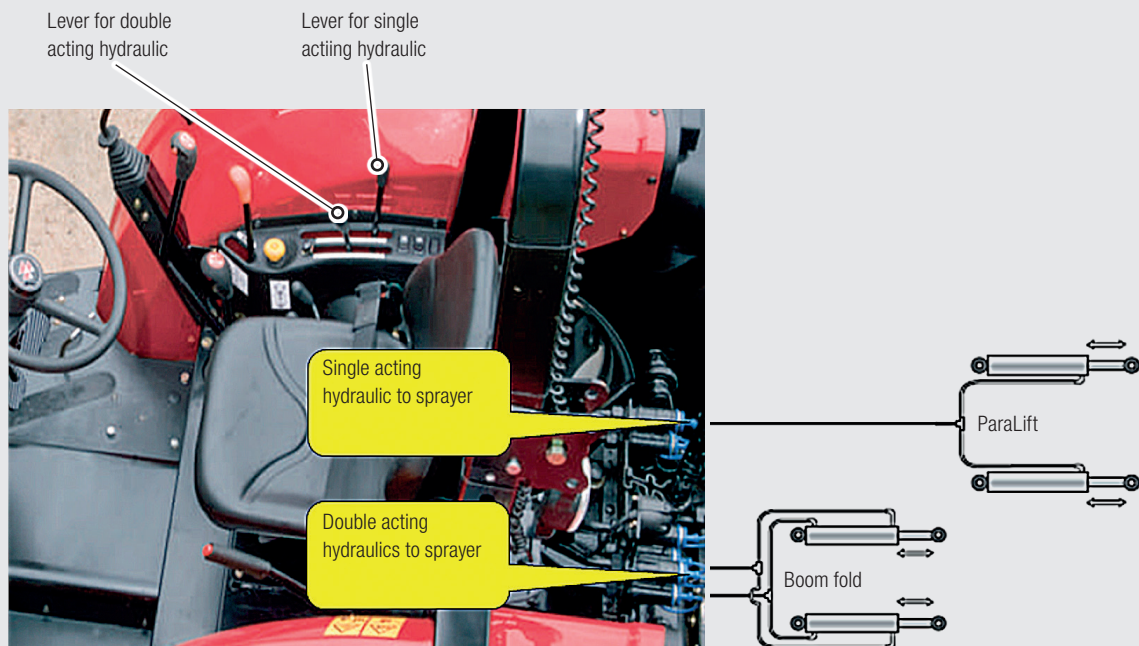

HARDI “Y” hydraulic function

The remote operation of the sprayer reduces operator contamination and often necessary as sprayers become larger and larger.

The simple remote operation of the boom hydraulics is done via the hydraulic levers on the tractor. At HARDI, we call this the “Y” hydraulic functions. Single acting operation is where the weight of the component forces the oil back to the tractor. It requires one outlet on the tractor. Double acting operation is where the oil direction can be reversed to force the component to perform the opposite function. It requires a double outlet on the tractor.

HARDI “Z” hydraulic function

If the sprayer has many hydraulic functions, the tractor will not have enough hydraulic outlets. By using an electric control over the hydraulics, one double acting tractor outlet is sufficient to control the sprayer. At HARDI, we call this the “Z” hydraulic functions and the sprayer has a control box for the hydraulic functions. It requires a double outlet on the tractor.



”Z”: Tractor hydraulic activation

Tractor hydraulic block

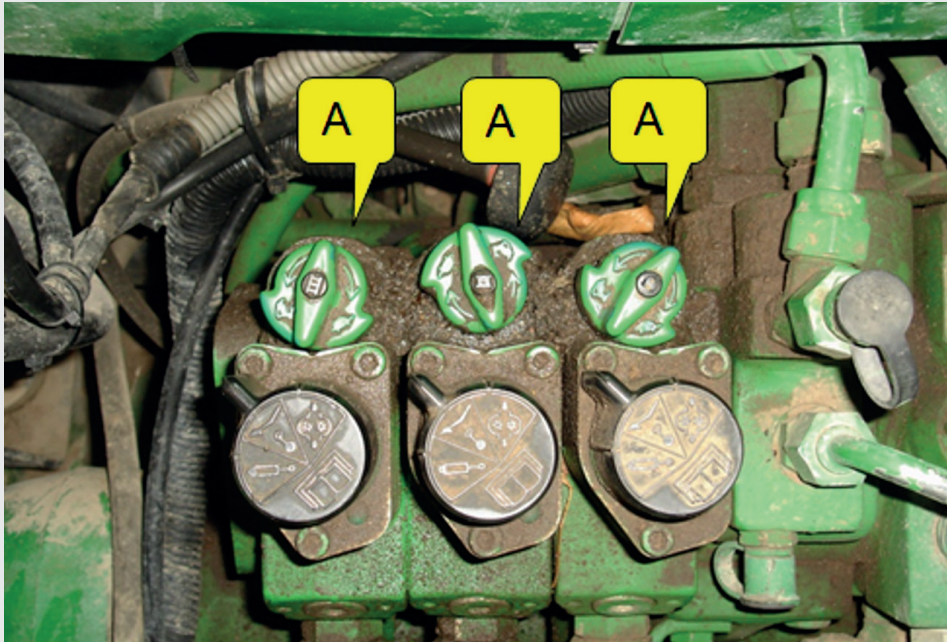

Tractor oil supply

The tractor oil supply is often adjustable and it may need to be matched to the sprayer requirements. Excessive supply can result in violent boom movements and little or no damping effect on tracking systems. This is often overlooked when operators change the tractor and implement combination.

Consult the tractor instruction book or use the below procedure to set the flow:

- 1 Set tractor oil flow to max.
- 2 Note time to raise boom
- 3 Reduce oil flow until time to raise boom is reduced (A)
- 4 Increase oil flow setting a little (A)

For a sprayer with boom plus tracking hydraulics, the maximum oil usage is approx. 35 l/min. (9.2 US gal/min)

For sprayers with tracking and boom management systems, the sensitivity test should also be re-done.

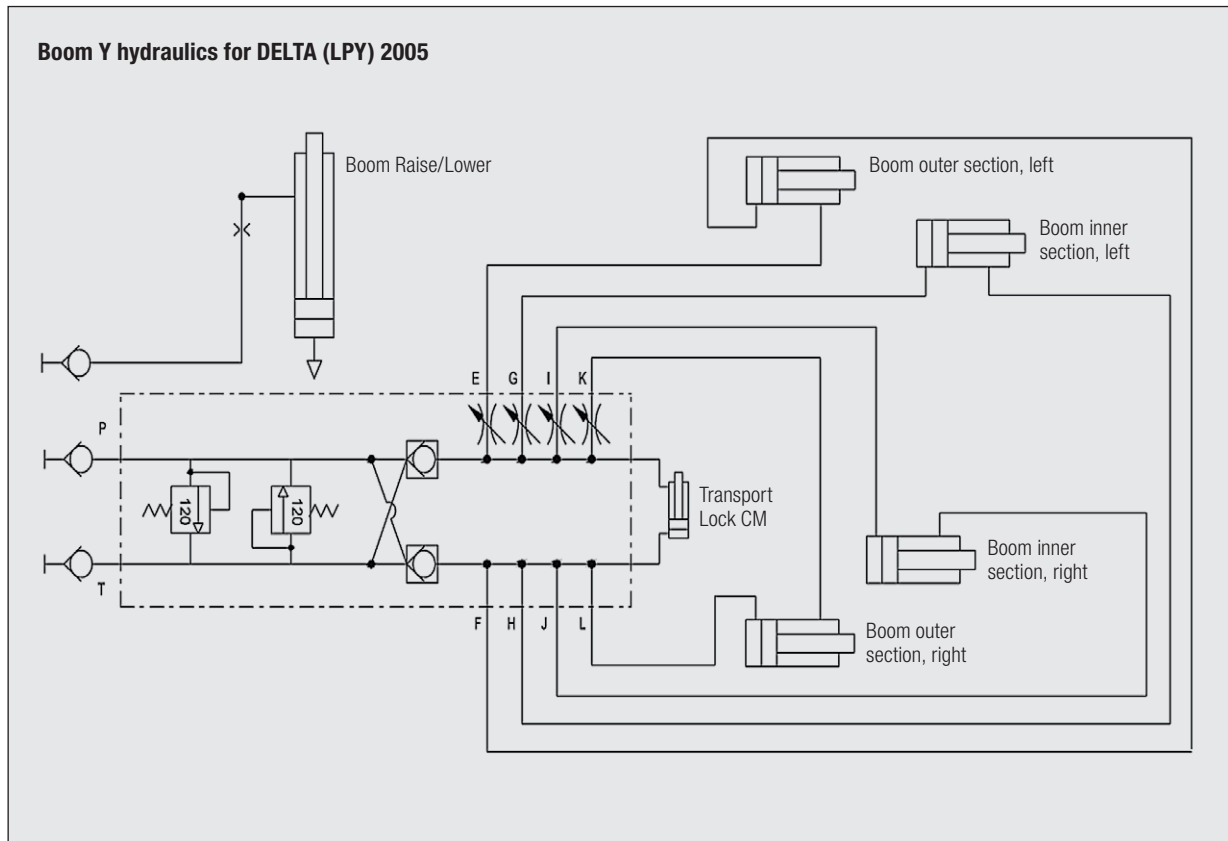

HARDI Y hydraulics

The single acting function is used to raise the boom. It requires one outlet on the tractor. The double acting function to fold and unfold the boom requires a double outlet on the tractor and the connections on the diagram are marked "P" (Pressure) and "T" (Tank; return to tank).

A spring loaded safety-return valve marked "120" will open and dump to the oil in the return line if the pressure exceeds 120 bar (1740 psi).

If the tractor hydraulic system is worn, oil will weep back to "T" (tank) and the boom will lose its rigidity. The non-return valve, fitted after the safety valve, prevents oil returning to the tractor.

The oil pressure at P port opens the non-return valve on return side, allowing oil to flow back to tractor tank via the T port allowing cylinder movement.

The restrictors, E, G, I and K, can be adjusted to reduce the oil flow to prevent boom damage if the movements are too violent.

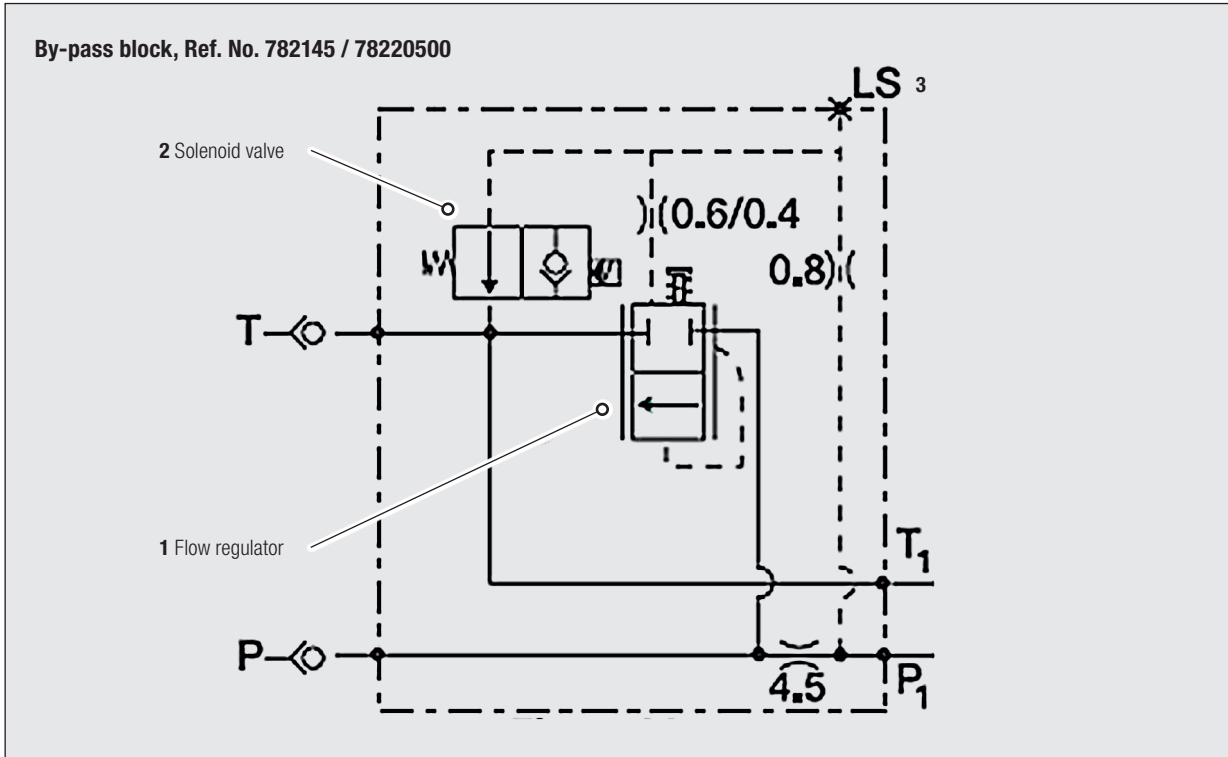

Z hydraulics; By-pass block

The by-pass block is needed for tractors with open centre hydraulics or if using load sensing from the tractor.

When no hydraulic function is in use, the solenoid valve will be open. This causes the flow regulator to slide to open position and the oil is circulated back to the tractor.

When a hydraulic function is activated, the solenoid valve is also electrically activated and will close. This causes the flow

regulator to close, and thereby the pressure increases which in turn can carry out the activated function on the sprayer.

If the by-pass block is fitted to the sprayer, the sprayer can be used with all tractor hydraulic types. The below table indicates settings. This information is found in the sprayer instruction book

Tractor hydraulics	1 Regulator	2 Valve 0	3 Load sensing
Open centre	Out	Out	Not fitted
Closed centre	In	In	Not fitted
Load Sensing	In	Out	Connected



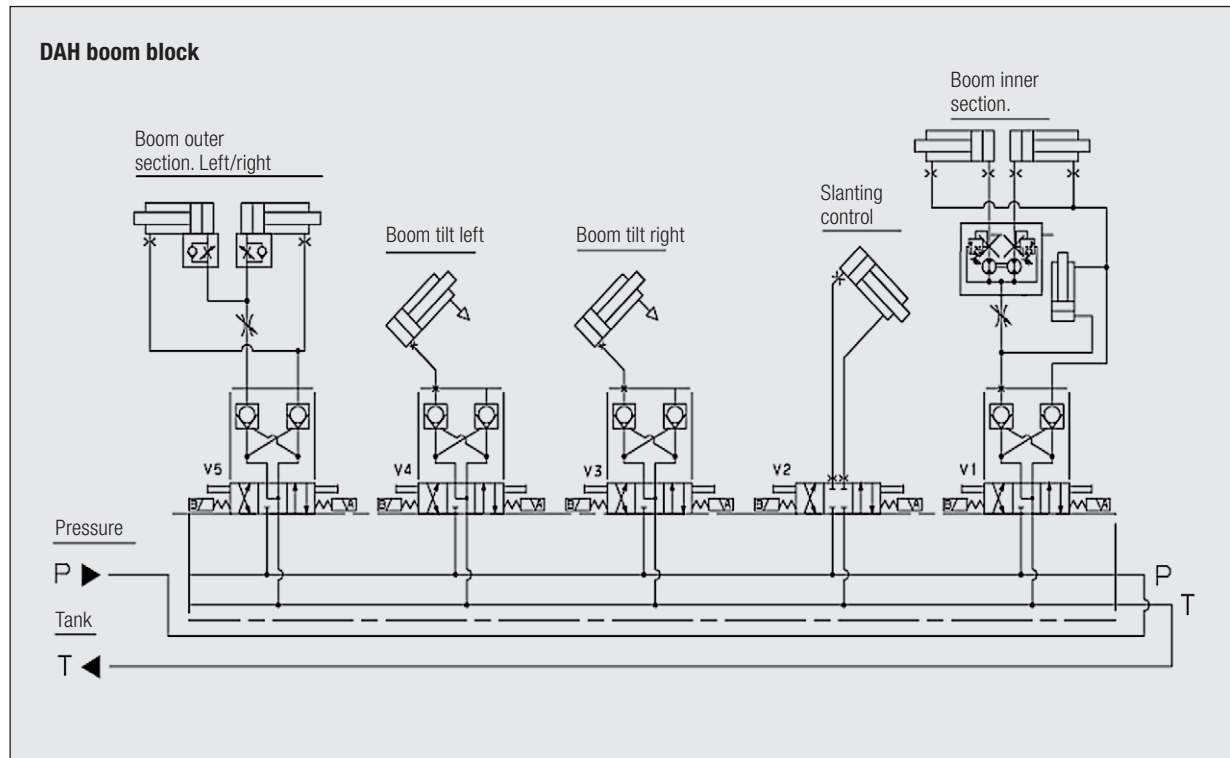

Direct Acting Hydraulics

The Direct Activating Hydraulics (DAH) has spool valves at every function. The solenoid valve pushes the spool in one of two directions to open an oil flow to the cylinder.

The "A" valve normally causes the cylinder to extend and the "B" valve to retract.

The older solenoids had buttons on the ends so in case of electrical failure, the boom functions can be operated manually by pushing on the buttons. Oil pressure to the hydraulic block is necessary and for an open centre hydraulic system, you had to set the by-pass block to closed centre for this emergency operation.

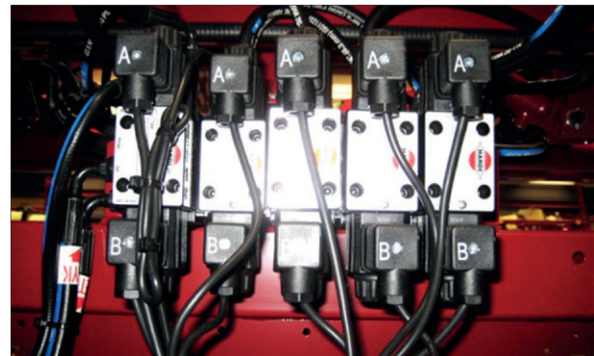

Indirect Acting Hydraulics

A low cost version of DAH was also available. This combined operation of a grip-like switch box for the hydraulic valves that was physically connected to the hydraulic lever. Operation involved activating the switch and moving the lever in the appropriate direction. It was called Indirect Activated Hydraulics (IAH). It was discontinued in 2000.

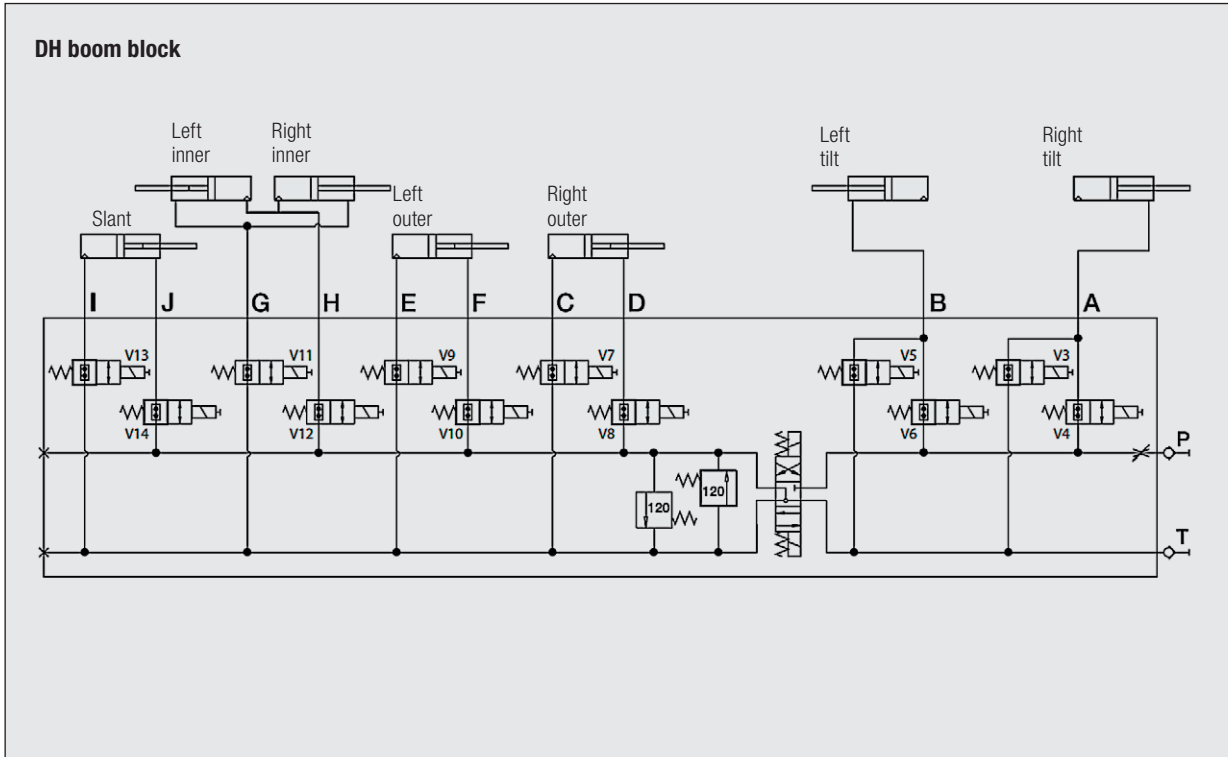

Direct Hydraulics

The Direct Hydraulics (DH) has only one spool valve to change the direction of the oil flow.

The other valves are of the solenoid ON/OFF type. They allow oil to flow to and from the cylinder or seal off both cylinder ports.



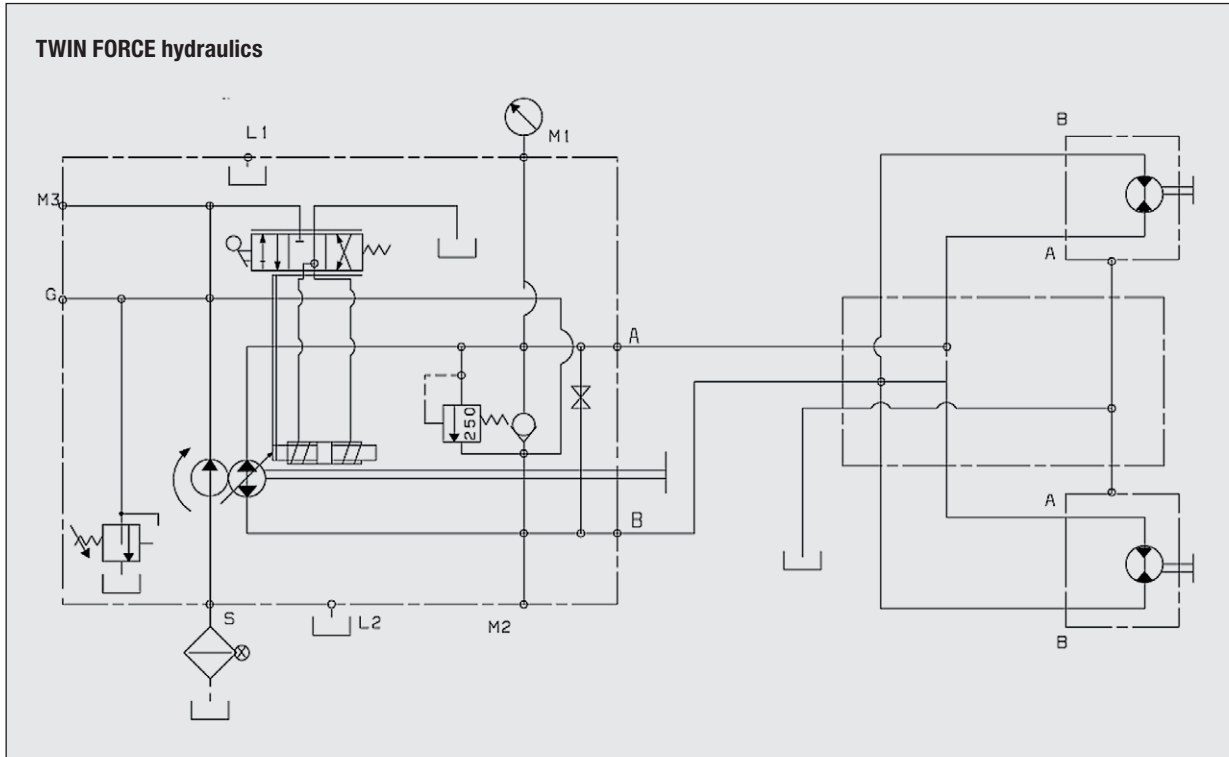

HARDI TWIN FORCE Hydraulics

The hydraulic transmission of the TWIN FORCE is self-contained as it has its own hydraulic pump to drive the two fan motors. The pump is driven from the tractor PTO via a through shaft on the spray liquid pump to a step-up gearbox with a ratio of 1:3. A 10 micron filter in the circuit maintains the oil purity.



CHAPTER 8

Booms



A self-propelled sprayer with an 8-metre front mounted boom from the 1960's



The task

The boom has the simple task of holding the nozzle at a set height over the target. This is relatively easy with a small 6 m (18 ft.) wide boom but becomes increasingly difficult when booms become wider, travel faster and when turning at the headland.

Booms must also be robust, offer nozzle protection, be compact when in transport, have minimal maintenance requirements and be able to sustain ground strikes without sustaining damage.

Wider booms are typically suspended so as to have an independent freedom of movement from the sprayer chassis. Trapeze and pendulum linkage suspensions are most common.

It is a major advantage that the boom mass is as light as possible so the construction lasts longer and the soil compaction is minimal. Lightweight high tensile tubes are often used for this reason.

Some booms are air-assisted to increase spray capacity and reduce pesticide use. Wide booms benefit from electronic boom management systems to maintain the set height.

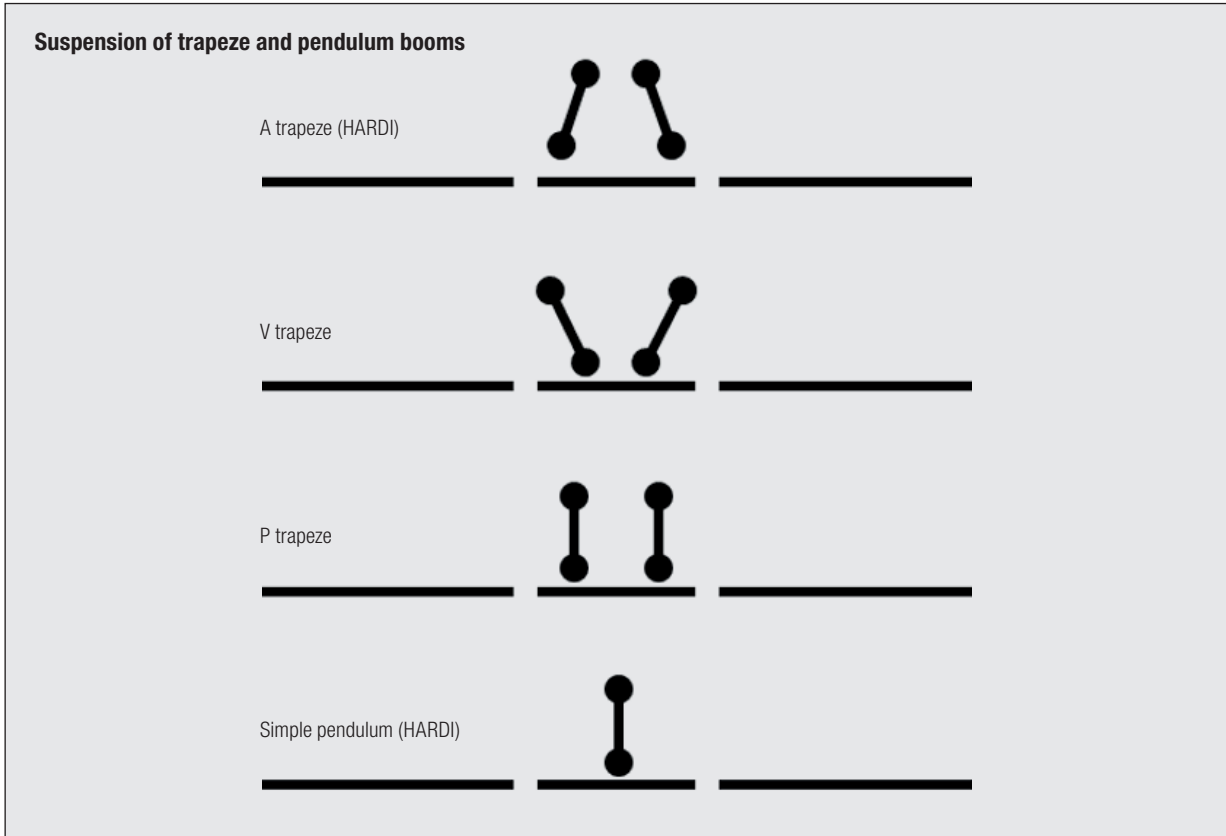

Boom suspensions

Trapeze and pendulum linkage suspensions are commonly used. When spraying, the boom is unlocked so it is independent of chassis movements. This helps maintain a set height over the target and also protects the boom from self-destruction. If the user sprays with the boom suspension in locked position, the boom will be severely damaged within a short time span. The lock function is used to ease folding and unfolding of the boom.

Boom stability and longevity will also be increased with axle suspension and tandem axles on trailed sprayers and suspension in the lift mechanism of the central boom section.

HARDI favours "A" trapeze and simple pendulum linkage suspensions. Some of the latest boom models like TERRA FORCE and DELTA FORCE booms combine features of both linkage suspension systems.

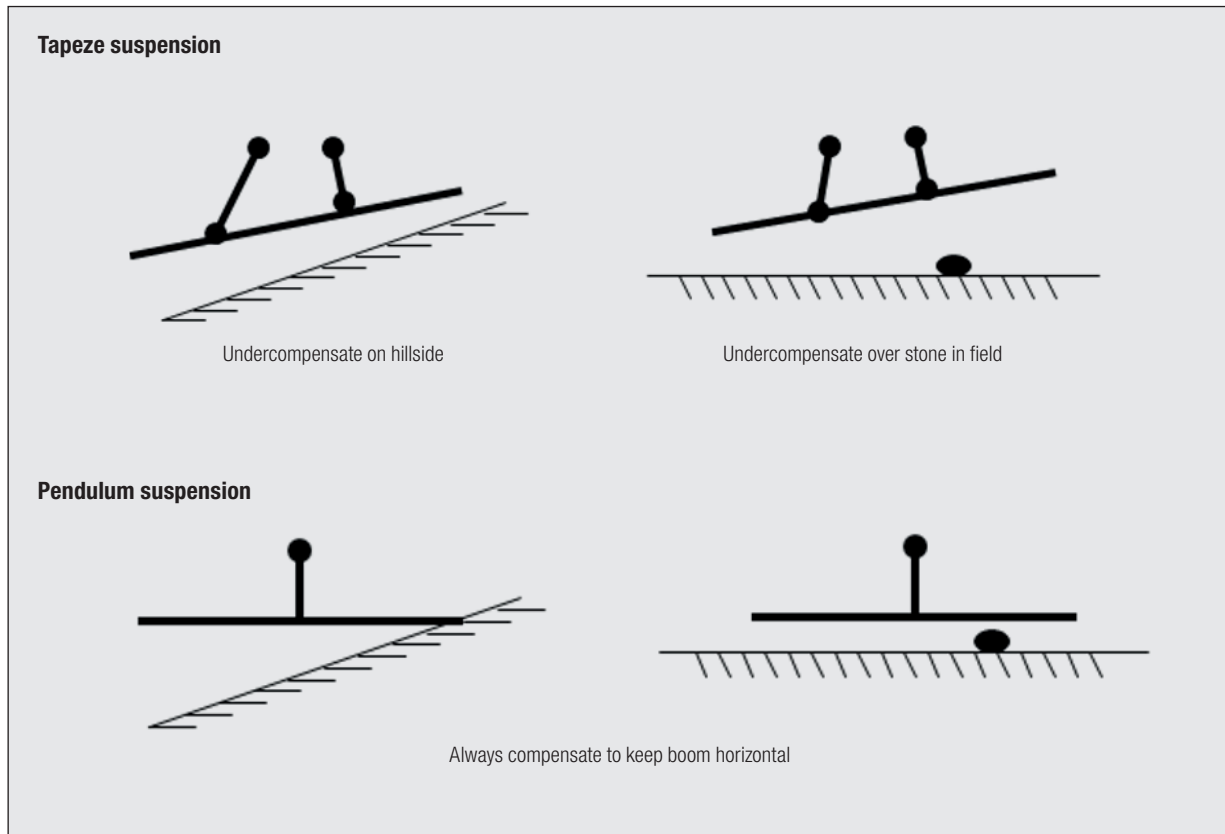

The A trapeze

The trapeze suspension is favoured on smaller and older HARDI booms. It is used on MB, PRO, TWIN STREAM and EAGLE booms. It is a simple construction and reasonably stable when turning. It is somewhat slower to react and requires more routine service and adjustments.

The Pendulum

The pendulum suspension is on most of the HARDI booms over 20 m (60 ft.). It is used on DELTA, FORCE and TWIN FORCE booms. It is quick to react and does not require much service or maintenance.

It is not stable when turning as the centrifugal forces cause the boom to dip on the inner circle side. For spraying along hillsides, it will require a slant compensation system.

Tapeze suspension

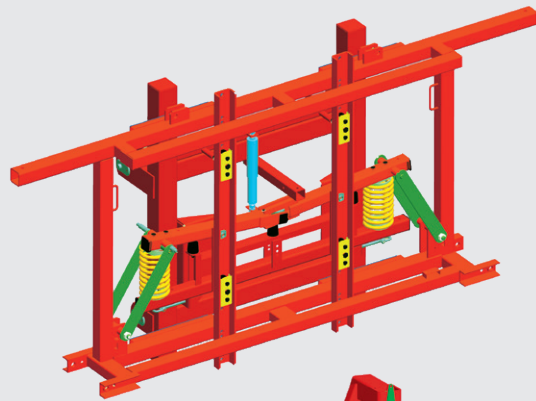

Pendulum suspension

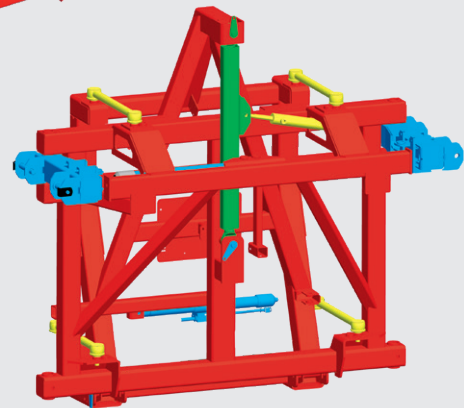





The A trapeze

In the "A" trapeze, a virtual suspension point is found if the arm lines are followed upwards so hence the name "A" suspension. The mechanism must not be too tight as this will hinder the movements or too loose as this may allow excessive boom movement. It also needs regular lubrication.

The Pendulum

The system can best be compared to a "Grandfather" clock with the pendulum being able to freely swing from side to side. Four service-free arms stabilise the centre boom part in position.

Tapeze suspension

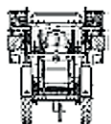
Name	Code	Size (metre)	Notes	
Small Boom	SB	6-10	No suspension, manual cross folded	
Medium Boom	MB	12	Trapeze, manual cross folded	
TWIN STREAM	HAL	12-15	Trapeze, Air assisted	
PRO	VHY VHZ VPZ	12-18 12-18 20-24	Trapeze	
EAGLE	SPB SPC	18-21 24-30	Trapeze	

Boom abbreviation codes and names

The HARDI booms have a common name and code. The code letters are abbreviations of the common name and can also indicate the hydraulic system "Y" or "Z".

Code	Common name	Description
SB	Small Boom	
MB	Medium Boom	
HAL	TWIN STREAM	HARDI Air-assisted Light
VHY	PRO	Vertical HARDI Y hydraulics
VHZ	PRO	Vertical HARDI Z hydraulics
VPZ	PRO	Vertical Pommier Z hydraulics
SPB	EAGLE	Spring B version
SPC	EAGLE	Spring C version

The bigger booms

Name	Code	Size (metre)	Notes
DELTA	LPY	18-28	Pendulum
	LPV	18-28	
	LPZ	18-28	
DELTA FORCE	DDZ	32-36	Pendulum
FORCE	HPZ	24-36	HPZ = Pendulum
	FTZ	24-36	FTZ = Trapeze (AUS & USA)
TWIN FORCE	HAY	18-30	Pendulum, air assisted
	HAZ	18-36	
TERRA FORCE	TDZ	36-42	Pendulum & trepeze

Code	Common name	Description
LPY	DELTA	Light Pendulum Y version
LPV	DELTA	Light Pendulum V version
LPZ	DELTA	Light Pendulum Z version
DDV	DELTA FORCE	Delta Dynamic centre V version
DDZ	DELTA FORCE	Delta Dynamic centre Z version
HPZ	FORCE	Heavy Pendulum Z version
FTZ	FORCE	Force Trapeze Z version
HAY	TWIN FORCE	Heavy Air-assisted Y version
HAZ	TWIN FORCE	Heavy Air-assisted Z version
TDZ	TERRA FORCE	Terra Dynamic centre Z version

Setup guide from the instruction book of the 1982 MINI Variant with 10 spouts

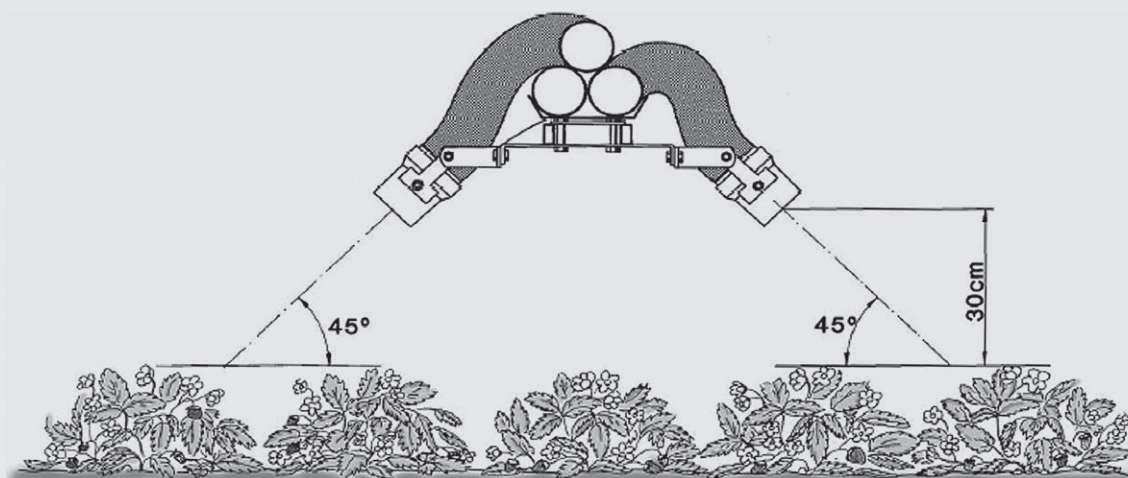

A 12 m (40ft.) Variant prototype from 1986 with 24 spouts



Air-assisted booms

The HARDI TWIN FORCE and TWIN STREAM are air-assisted booms. With the TWIN system, it is possible to infinitely adjust the air volume from no air to maximum air. It is two sprayers in one and hence the name TWIN. The TWIN system increases crop penetration of the pesticide and sprayer capacity. It reduces spray drift, water volume rate and pesticide dosage.

The TWIN concept grew from the HARDI MINI Variant, a 6 m (20 ft.) sprayer for strawberries. It had 10 individual spouts

that could be angled according to the crop. The benefits of this application method soon found its way to broad-acre crops. The TWIN system producing a curtain of air through a slot that could be angled forwards and backwards became commercially available in 1987. Both air volume and spray angle can be adjusted on the go.

The customers using the TWIN claim 64% higher spraying capacity, 32% drift reduction, 30% in pesticide savings and use 30% less water.

HARDI TWIN FORCE with and without air showing the marked increase in spray drift

Air-assisted booms

The TWIN FORCE system is self-contained with a hydraulic pump and two hydraulic motors to power the two fans on the sprayer. Boom sizes start at 18 m (60 ft.) and end with 36 m (120 ft.). The boom has a pendulum suspension.

The TWIN STREAM is a smaller, economical version where the tractor supplies the oil. The sprayer only has one hydraulic motor to power the one fan on the sprayer. Boom sizes are 12 m (40 ft.) and 15 m (50 ft.) and both have a trapeze suspension.

Alternative booms designs



Alternative boom types

Different local and national traditions have influenced the boom design. It is often a combination of many factors promoting the existence of this equipment. It may be suited to one area but a complete failure in another area.

Centre-mounted booms

For smaller booms for pasture improvement, a skid-mounted sprayer is an option. Some skid-mounts have centre-mounted booms for a better boom ride and application job.

Wheeled booms

If speed and operator comfort along with low crop density and application rates are the key values, then a wheeled boom can be a good alternative. These have typically been popular in broad-acre farming areas of Australia and Western Canada.

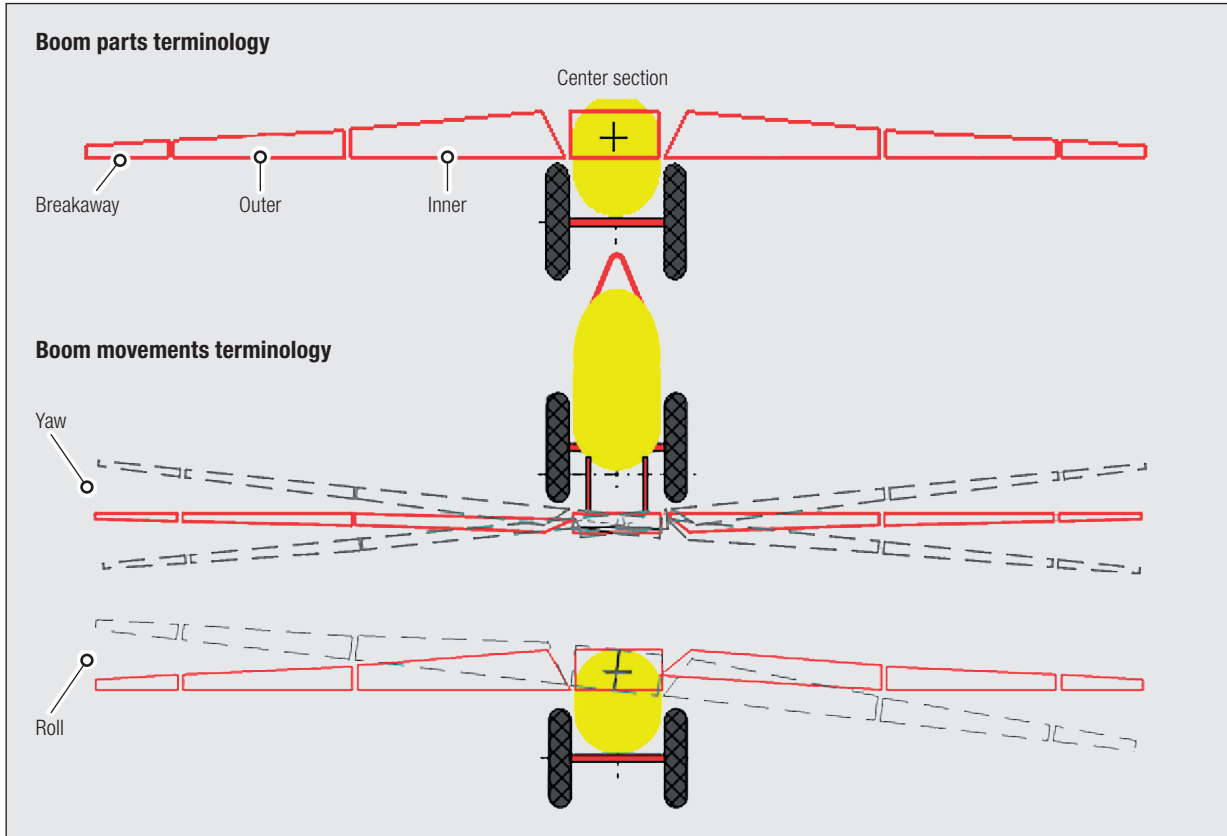

Terminology of boom parts and movements

The boom sections are as follows:

Breakaway – It must be able to move backwards or forwards if it strikes an object

Outer – Hinged at outer/inner section

Inner – Hinged at inner/centre section

Centre – Has the suspension function

Some booms can be partly folded at the inner/outer hinge. This function is used for spraying on areas with limited space, e.g. at headlands.

Yaw is the forward and backward movement of the boom wings. Damping systems are set up to absorb the forces that would normally damage the boom under severe braking or turning.

Roll is the upward and downward movement of the boom wings. Neither yaw nor roll is a desired movement as they contribute to application inaccuracy.

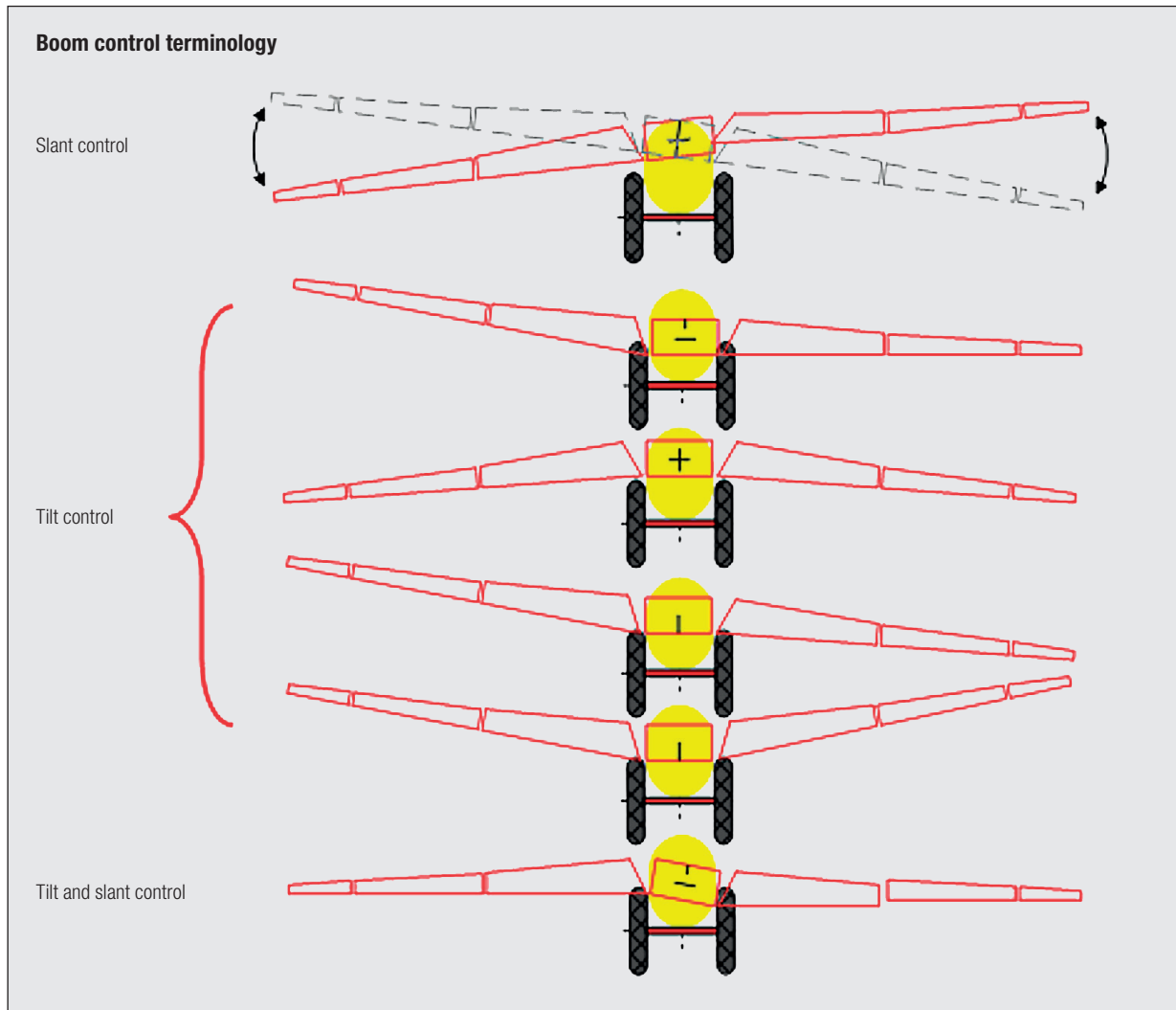

Terminology of boom controls

Y boom requirements are:

- ▶ One single acting outlet for (up/down)
- ▶ One double acting outlet (fold)
- ▶ One double acting outlet (slant)

Z boom requirements are:

- ▶ One double acting outlet (for all movements)





CHAPTER 9

Tanks & Frames

Tank design.

Picture showing powder materials in the bottom half of tank form

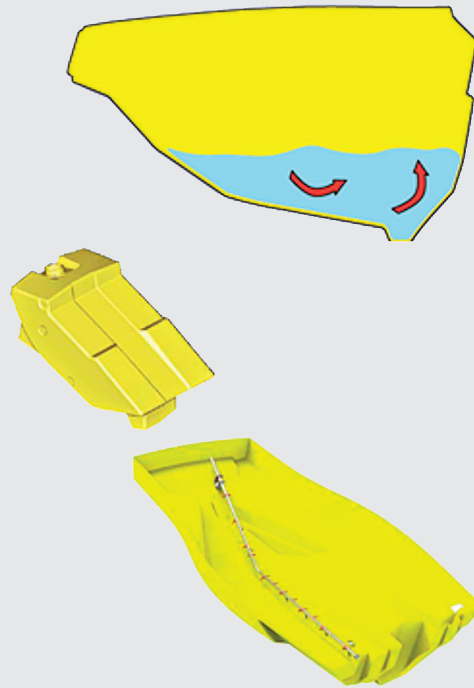

General principles of tank design

The desirable features of a sprayer tank are many and HARDI fulfils the following:

- ▶ The sump must be deep as we do not want residues
- ▶ A third weight must be on drawbar to aid traction on hills
- ▶ It must be free standing to minimise weight that would otherwise damage the field
- ▶ It must be stable under hard braking and without baffle plates to ease cleaning
- ▶ The agitation should have minimal pump capacity use yet be effective
- ▶ The sprayer must be stable when turning with maximum weight on axle
- ▶ It must be easy to clean with no sharp corners and a smooth inside
- ▶ The tank must have a long life, be impact and UV proof
- ▶ It must adhere to the European Norm (EN) and local regulations

The original HARDI tanks were metallic, typically stainless steel. In the 70's, HARDI pioneered the use of polyethylene tanks in agriculture. It was favoured because it was a safe process for production staff, all waste is recycled and many of the desired features could be achieved.

Stainless steel tanks have "bling" or "high-end look" effect for the potential customer, but the manufacturer typically uses this material because the investment is less for a low quantity production of tanks. Impact and difficult to clean sharp corners can be an issue with metallic tanks.

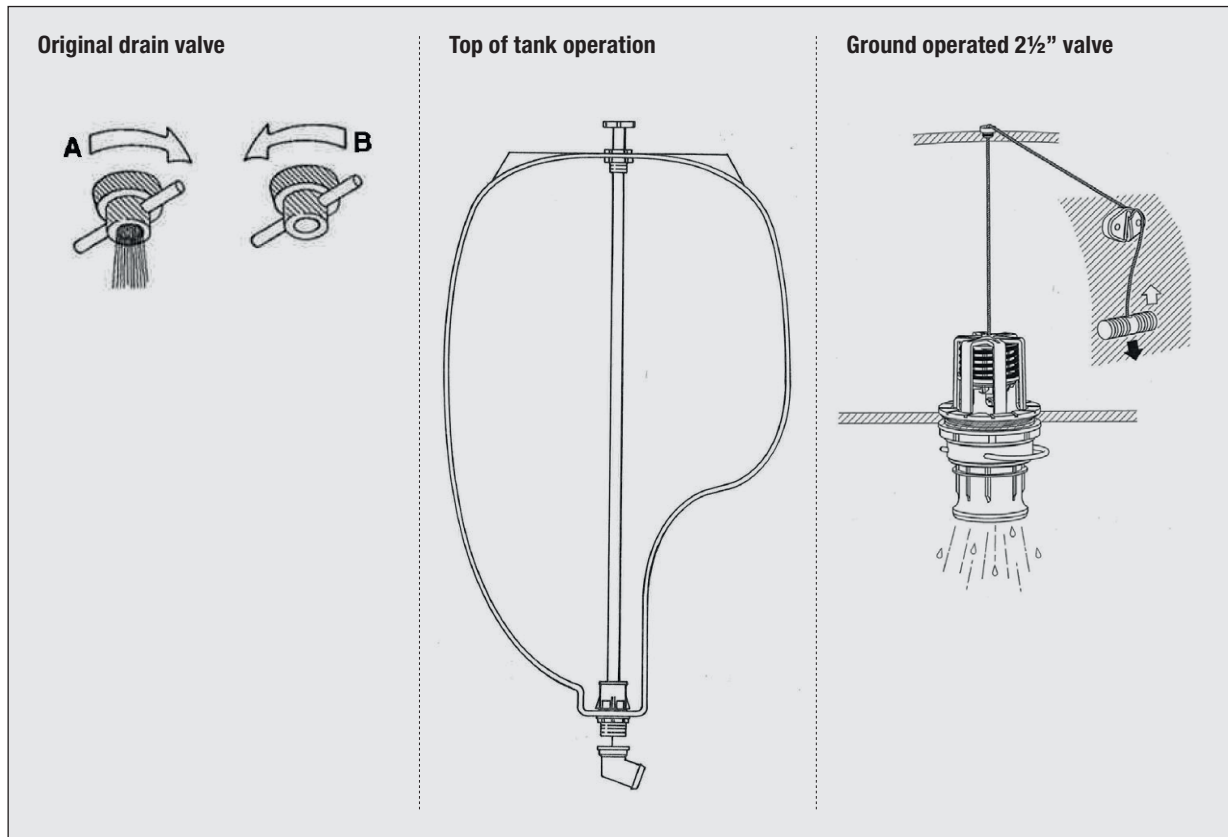

Drain valves

The classic drain valve is basically a threaded blanked cap. This will not do for a modern sprayer. Functional design and consideration to operator safety make for better systems to drain or transfer tank contents.

The older drain valve had a threaded plug that could not be lost. The small flow capacity, the not-so-handy placement to operate the drain and the fact that the operator comes very close to the residues lead to a new design with top-of-tank operation, increased flow capacity and the possibility to attach a hose.

As the tanks got larger and larger, the demand to quickly empty the tank increased and a new design was introduced on the large tanks in the 90's. It is a 2 1/2", spring-loaded valve that could be operated from the ground and serviced from the outside of the tank.

To service the drain valve, the U-clip on the valve is removed and the seat and body with valve seal can now be pulled down for inspection and eventual service.

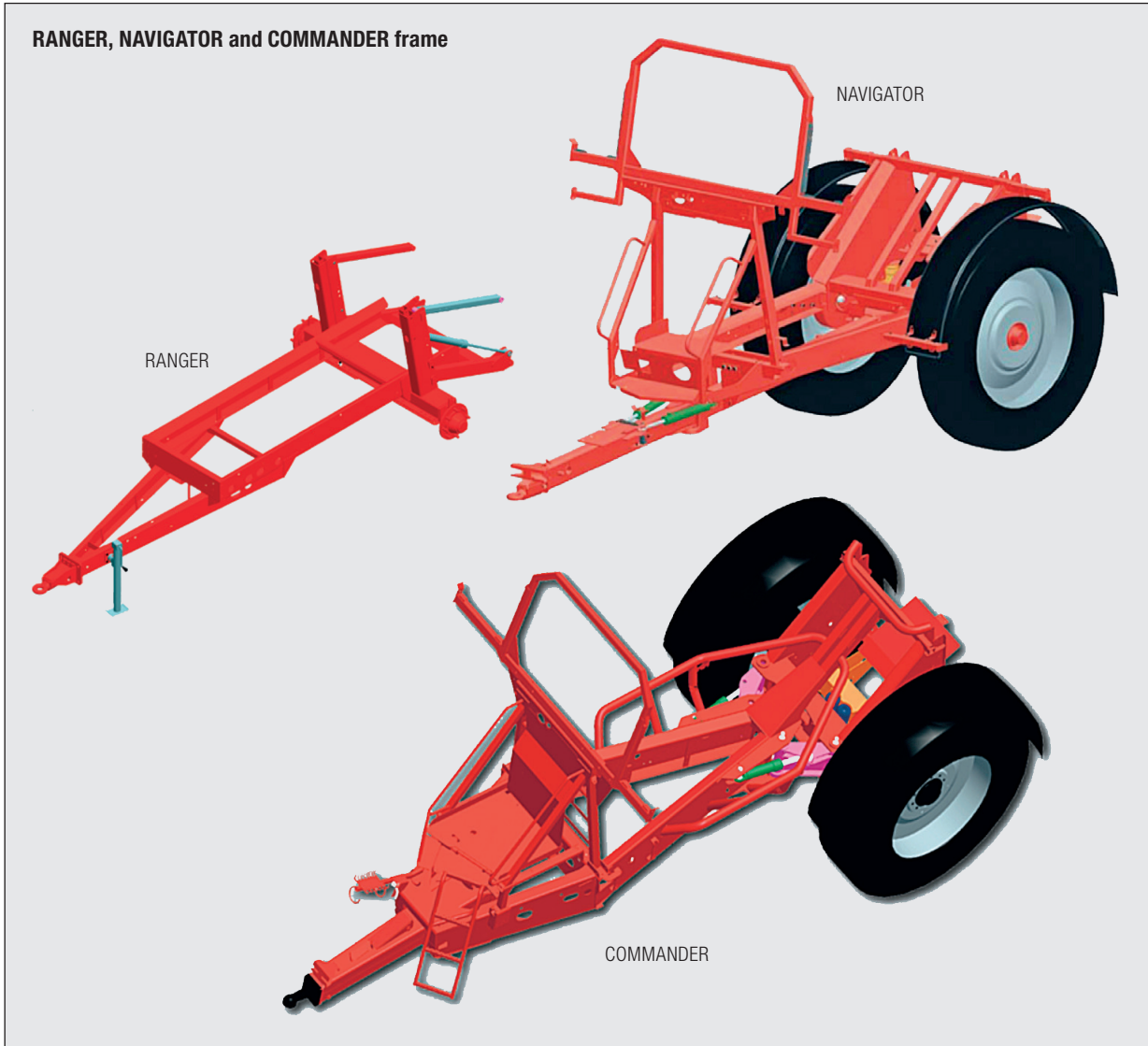

The Frames

Since the introduction of the 2005 COMMANDER, NAVIGATOR and RANGER, the use of DOMEX high-tensile steel has been extensive to reduce sprayer weight and consequently reduce soil damage in the field.

For the best stability at faster spraying speeds, the rinse tank on all these models is placed over the axles. A rinse tank fitted at the front of the sprayer with an extra weight of possibly 600 kg (1300 lb.) will destabilise the sprayer when turning.

The frame should offer a good clearance with a smooth belly so as to minimise crop damage. Options like brakes should have no appendages that hang down in the crop and thereby damage it.



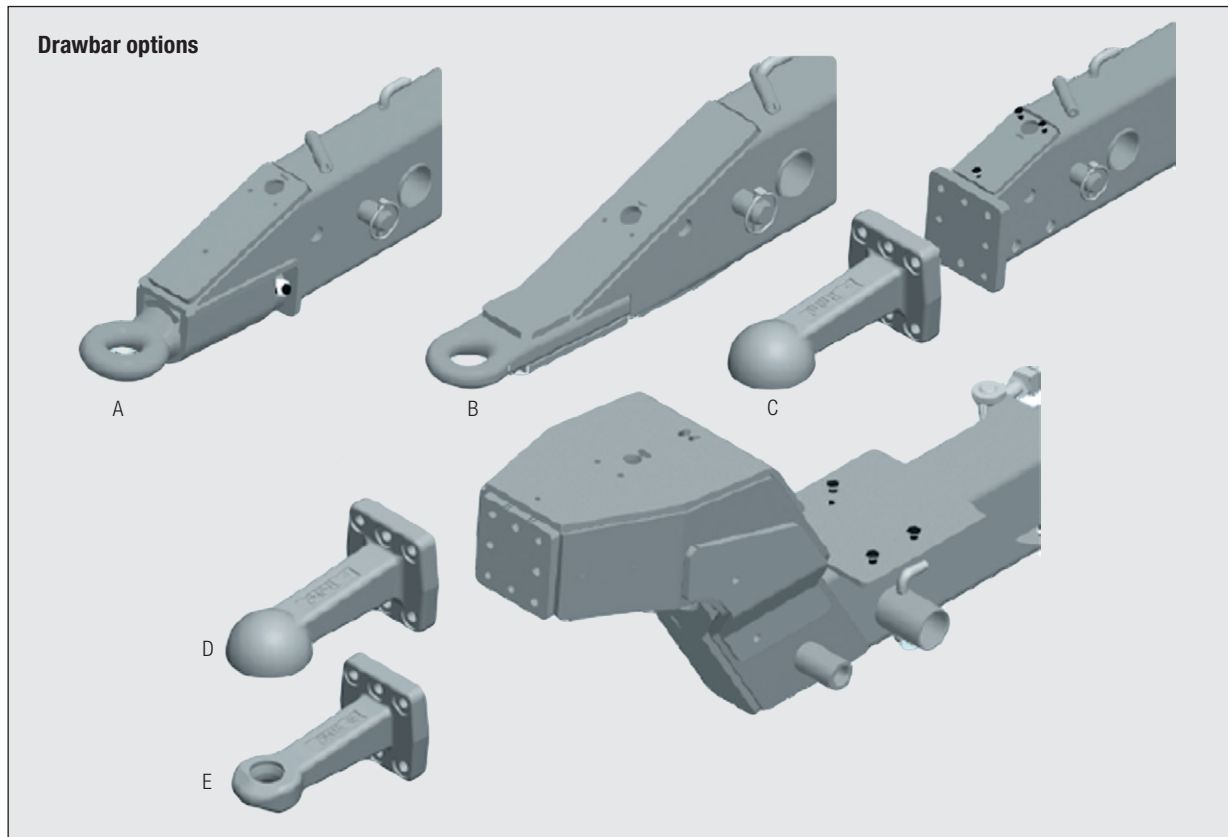

The Drawbars

There are a number of drawbar options as the requirements differ from country to country. Most are the “Low” type but a few countries have a tradition of using a “High” hitch drawbar. The transmission shaft passes through this type of drawbar.

The drawbar hitch eye is mostly bolted to the bar but a few are welded. The “Kugel” (C & D) or ball type with 80 mm diameter has become popular as it is easier to connect the sprayer to tractor. The typical hitch eye (A & B) diameter is either 50 or 33 mm. The Zugmaul (E) eye diameter is 40 mm. This is typically used on the High-hitch drawbars.

On smaller sprayers, a swivelled forked hitch is also an option.

The larger sprayers may be supplied with a suspended drawbar. This gives a smoother ride for both the boom and operator.

At least a third of the sprayer weight should be on the drawbar eye. This weight distribution is critical for tractor traction when the tractor is pulling the sprayer up a hill.

Suspension systems



Frame suspension systems

Suspension of the sprayer became important from the 1980's when the operator wanted faster spray speeds for more spray capacity and the tanks got larger. The frame suspension offered a longer boom life, better boom ride and more comfort to the operator. Frame suspension is achieved in various ways.

Tandem axle suspension

They were sold in many countries with the introduction of larger tanks in the 1980's and very popular in North America and Australia. The simple "walking beam" construction achieves a better boom ride and less ground compaction. The drawback is the low ground clearance, the scuffing at turns and the wheels plugging up in muddy conditions. Most sprayers are now single axle constructions.

Rubber damper suspension

This is a common present day system that is low cost and does not require maintenance. The dampers are made of a rubber like material that finds original shape when weight relieved.

Hydraulic or Pneumatic suspension

This is now the typical high-end system. It offers high ground clearance and has accumulators that are pre-loaded to suit the weight of the sprayer.

SelfSteer mechanical tracking on a RANGER



Tracking systems

Self-propelled and lift-mounted sprayers have the advantage that they only leave one set of tracks. Trailed sprayers do not have this advantage. They need some form of articulation to achieve this. It can be a simple mechanical setup to computer controlled systems. HARDI has, at some stage or other, manufactured all the systems.

Tracking system should be disengaged when the sprayer leaves the field. At transport speeds, the sprayer can easily tip over if this is not done.

Mechanical steering

This is a simple mechanical system where the sprayer is attached to the tractor lift arms and the pivot point is ideally placed halfway between the rear wheels of the tractor and the sprayer wheels. An option, typically with hydraulic activation, to crab the sprayer to the upside on hillside spraying is advantageous so as to keep the sprayer in the tracks.

Wheel steering

This is a mechanism similar to the front wheels of a vehicle. It can be mechanical or hydraulic. It is very stable when turning but does have a limited radius and minimum track width compared to other systems, especially so with wide tyres. It also compromises the boom lift construction and placement of the clean water tank.

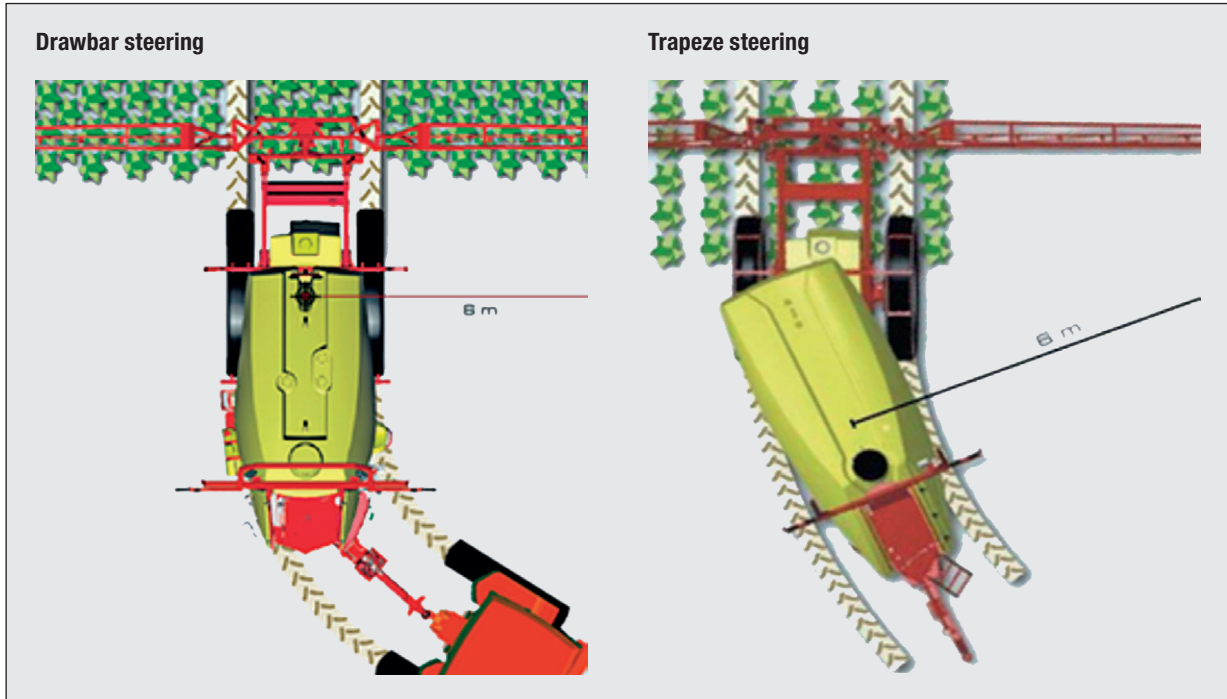

Tracking systems

Drawbar steering

This is the most common of all tracking systems. The pivot point is at the front of the sprayer and hydraulic cylinders force the frame to the correct angle. This can be done manually or electronically with the aid of an angle sensor at the tractor drawbar and at the sprayer drawbar. It does not hinder optimal ballast placement of the rinse tank or narrow track width settings. The turning radius is about 6 m (18ft.) The HARDI names are MULTI-TRACK, SELF TRACK, Steering Drawbar and IntelliTrack.

Trapeze steering

This is a unique steering method combining the stability of wheel steering and optimal ballast placement along with tight turning radius and narrow track width settings of the drawbar steering. The HARDI name is SafeTrack.

The IntelliTrack and SafeTrack are more than simple electronic tracking systems. They monitor speed, track width, turning angle, tank contents and a safety factor. Should the combination of these factors indicate a risk of tipping over, the system will automatically straighten the sprayer to avoid an accident. It is called DEC, Dynamic Electronic Control, and has been a unique HARDI feature since 2005.



CHAPTER 10

Blower units

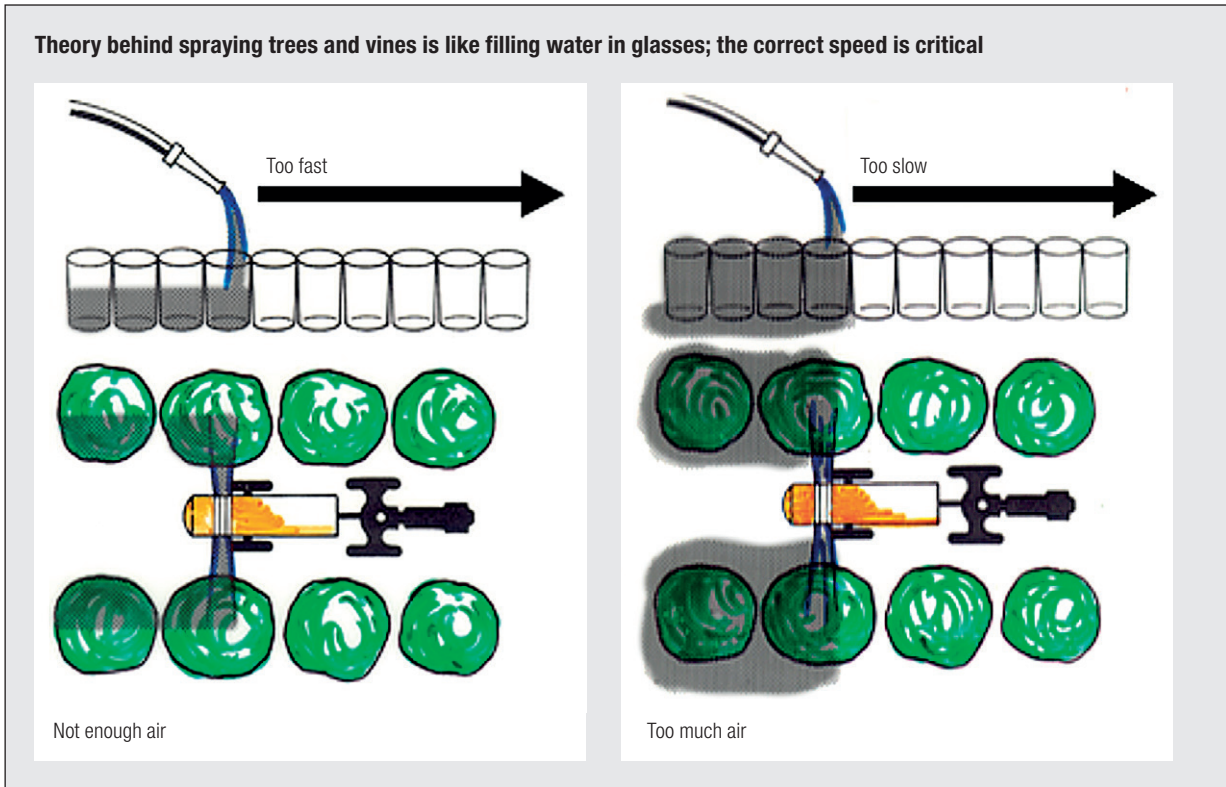

Vine and orchard sprayers or mistblowers

To understand blowers for vines and orchards, we need to understand the task. The function of a mistblower is to replace the air in the canopy with spray laden air from the blower unit. This means the blower must be capable of producing enough air to replace the air in the canopy at the intended forward speed. The blower unit introduces two important factors, the most important being air volume. It in turn relates directly to the next factor, forward speed.

The easiest mistake to make when spraying with mistblowers is to drive too fast. The excess speed does not allow the air time enough to fill tree. It is similar to filling a row of glasses with water from a hose. Move the hose too fast and the glasses do not fill, move it too slow, and they overflow.

A third factor could be the air speed. There is an inverse relationship between air speed and outlet area. As outlet area decreases, air speed increases. A large outlet area will obtain a lower, less aggressive air speed. On some blowers, outlet area can be reduced thereby increasing air speed and drop penetration.

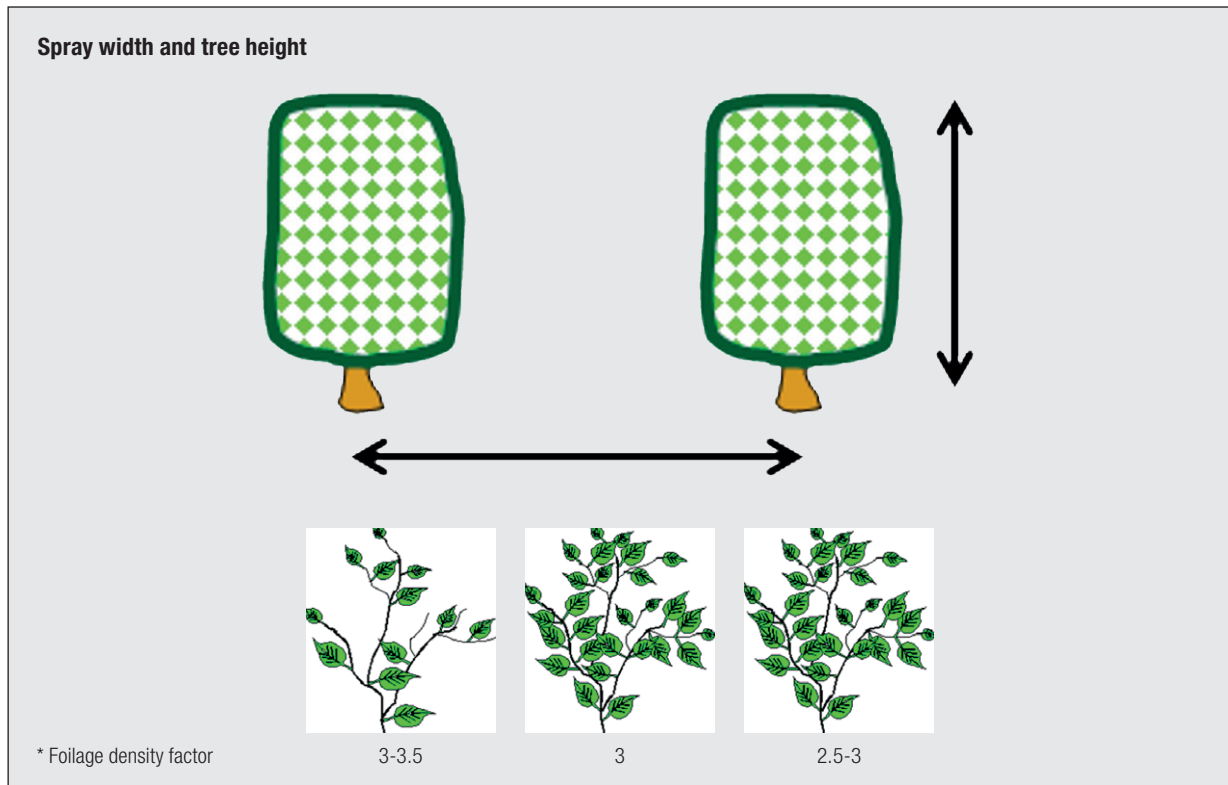

Air volume and driving speed

Volume is related to the aerodynamic characteristics of the blower housing and the rotation speed of the fan. The theoretical volume (m³/h) required for a given crop can be calculated after a desired speed. This is helpful information when purchasing a mistblower.

As a rule of thumb, at the optimum combination of air volume and speed, the spray will only occasionally penetrate through the row.

$$\frac{1000 \times \text{Speed (km/h)} \times \text{Spray width (m)} \times \text{Tree height (m)}}{3 \text{ (Leaf area factor*)}} = \text{Air volume (m}^3\text{/h)}$$

* For light foliage use factor 3.0 to 3.5. For dense foliage use factor 2.5 to 3.0

If the air volume is known, the following formula is a guide for maximum speed:

$$\frac{\text{Fan output (m}^3\text{/h)} \times 3 \text{ (Leaf area factor*)}}{1000 \times \text{Spray width (m)} \times \text{Tree height (m)}} = \text{Speed (km/h)}$$

A lift-mounted axial blower



Back-plate design to correct air delivery

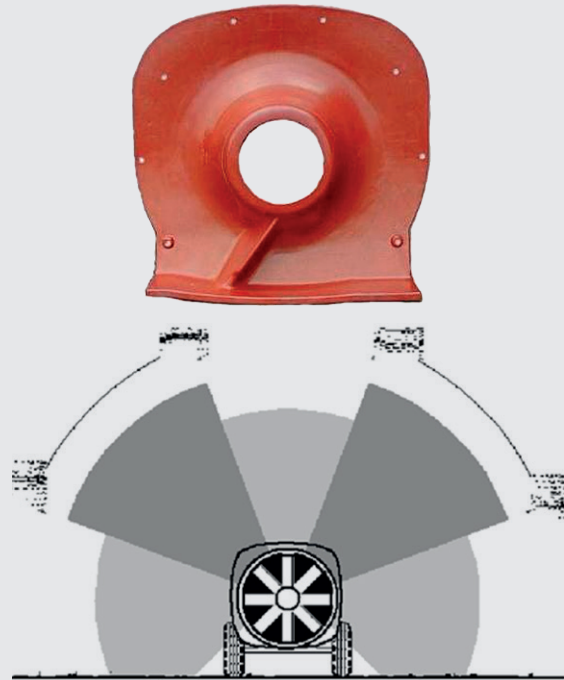

Axial blowers

Air flow in axial fans follows the axle of the fan (rotor) and has to be rotated 90° through special deflectors. They produce high, turbulent air volumes at (30-80,000 m³/h) at low air speed (20-40 m/s). The turbulence induces leaf movement that permits drops to penetrate and to be deposited on both sides of the leaves. They are used mainly for spraying large trees due to the high air capacity. Axial fans usually have adjustable blade angles. Increasing the fan blade angle will move a greater volume of air but also consume more power.

The rotation of the fan causes more air to exit from one side so a well-designed blower will have uniform air distribution to both left and right sides along with the possibility to scoop the lower air and put it into the densest part of the tree.

Typical use of centrifugal blowers in narrow rows



Pneumatic air shear nozzles



Hydro-pneumatic nozzles



Centrifugal blowers

These blowers produce high air speed (60-100 m/s) but low air volumes (5-20.000 m³/h). The blower typically has hoses and spouts to localize the air which is especially useful in narrow-rowed crops like vines.

Pneumatic nozzles (air shear)

These are used on pneumatic sprayers where atomization of the liquid is caused by high air speed at outlet. It is typically fine atomization of the liquid. The higher the air speed, the smaller the drops. Liquid flow is typically low pressure, 1 to 4 bar.

Hydro pneumatic nozzles

Droplets are produced by the liquid pressure passing through the nozzle orifice. Both FLAT FAN and hollow cone nozzles may be used in mistblowers, but the most commonly used are hollow cone nozzles.





CHAPTER 11

Special equipment

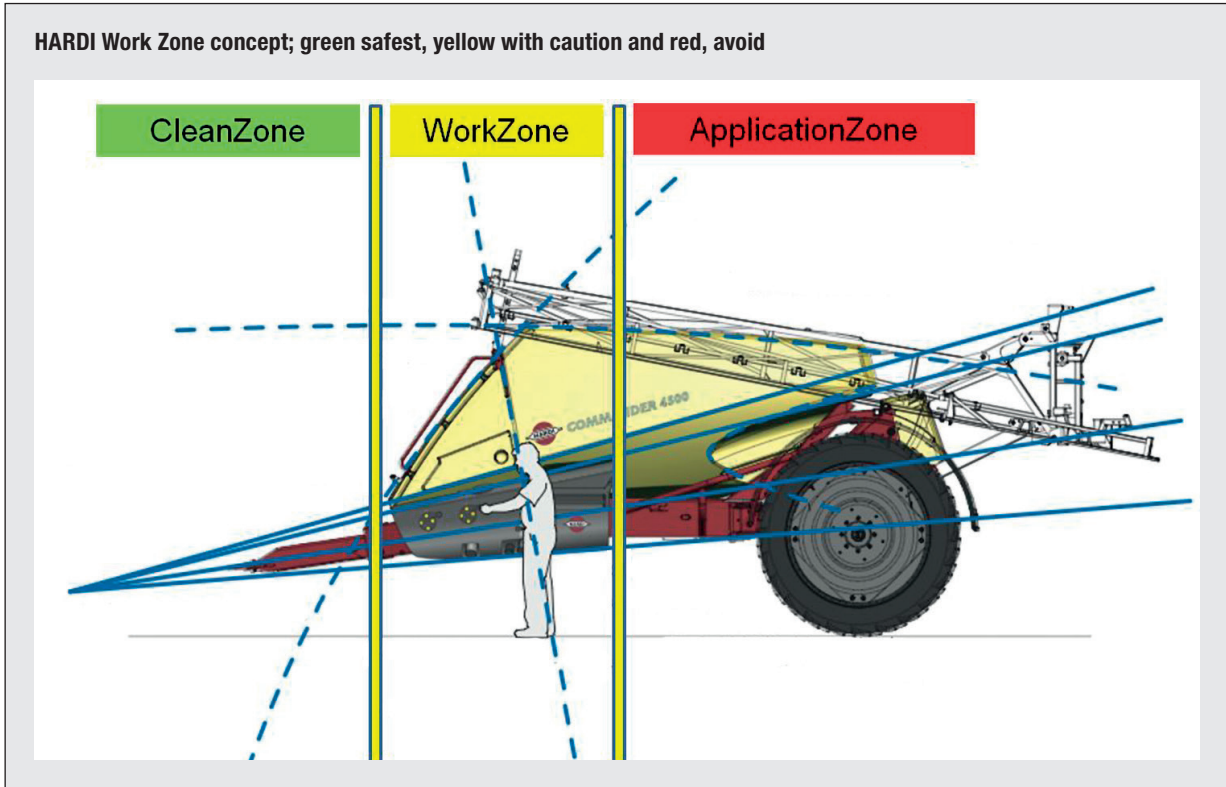

Operator safety and WorkZone concept

Design concepts from the introduction of the COMMANDER series takes into account the logical movements of the operator. We have a “WorkZone” concept that states there should be less risk of contamination the closer you get to the tractor.

For example, the storage locker for clothing is placed at the front (green zone). It would never be placed at the rear (red zone) of the sprayer as it is most probably contaminated by spray drift.

Placement of manually operated valves and equipment like pesticide transfer units is always on the left-hand side of the sprayer and as far forward as possible as most operators enter and leave the tractor cabin from the left-hand side.

EcoFill transfer system



Transfer system for small container

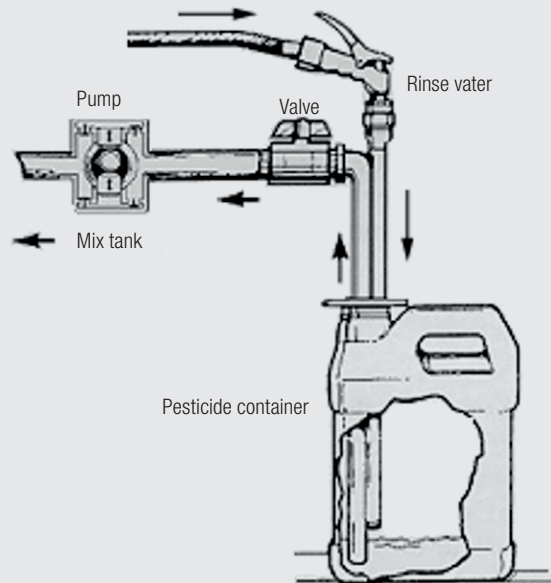

Transfer equipment

The transfer of pesticide from the container to the spray tank has to be done safely and easily. There is no standardisation on containers and the pesticide can be formulated in liquid, powder, granulate or tablet form. Furthermore, the sprayers have become larger and the health and safety authorities have increased focus on this work area.

In a perfect world, the pesticide remains in a closed container and only the required amount should be transferred to the nozzles. These systems have been tried and a couple are commercially available even though they have a number of negative issues e.g. how to handle powder and granulate formulations, cleaning feed lines with concentrated pesticide and maintaining a homogeneous mixture in the boom lines.

Semi-closed systems also exist, often instigated by the pesticide manufacturer, but are typically only available at regional levels. HARDI offers some of these as optional extras.

ChemFiller fitted to a lift-mounted sprayer and TurboFiller fitted to a trailed sprayer



ChemFiller and TurboFiller

HARDI has offered the ChemFiller from the mid-80's and the TurboFiller from 2007 as a transfer system that can handle liquid, powder and granulate material. They are ejector nozzle based transfer systems requiring about 10 bar/140 psi pressure to create a vacuum at the bottom of the transfer hopper. The ejector nozzle output is chosen in respect to the pump output.

The ChemFiller had a 25 litre/6½ gallon or a 35 litre/9 gallon hopper with a rinse ring at the top. The container and bag rinse spool nozzle was optional.

The ChemFiller on the COMMANDER from 2005 was incorporated in the sprayer and had a strong fold-down work table and a patented vortex nozzle setup to create good mixing and transfer of the pesticide.

A transfer device called GranniPot (picture at right) is offered on some regional HARDI markets. It offers a stand-alone unit and higher capacity compared to the ChemFiller.



The TurboFiller is now integrated on COMMANDER models. Detail of swirl-plate at bottom of hopper



TurboFiller

The need for a faster and safer transfer was key elements in the design of the TurboFiller. The rinse ring was removed and a deflector swirl-plate was added to the bottom of the hopper along with a rinse gun. The rinse spool nozzle became standard issue.

If the operator is not paying attention to the job, powder or granulate pesticides can block normal transfer systems. The wash liquid entering the hopper then overflows, contaminating the area and wasting the pesticide.

The TurboFiller is safer to use because it cannot block the wash liquid. The placement of the deflector swirl-plate always allows the wash liquid to return to the tank and at the same time gnawing away at the powder or granulate blockage. You can literally fill the hopper to the top and it will still work safely.

The faster transfer time was achieved by increasing the ejector nozzle capacity.

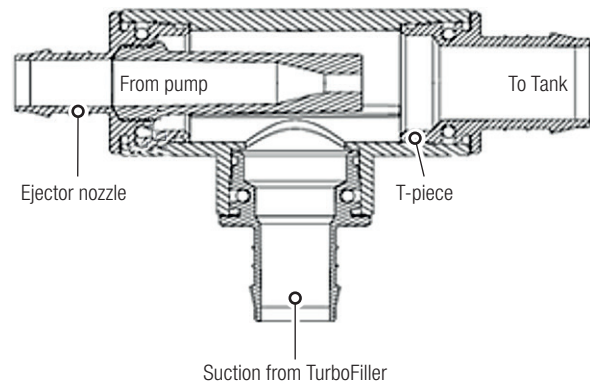





CHAPTER 12

Fittings

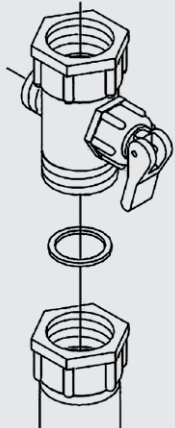
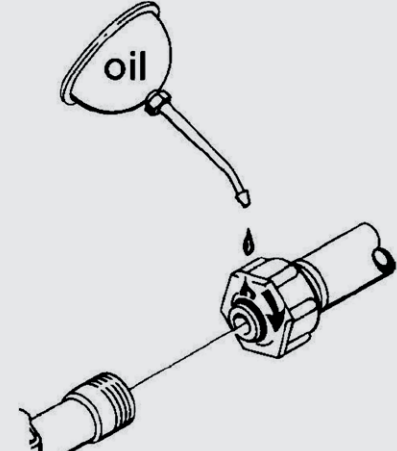
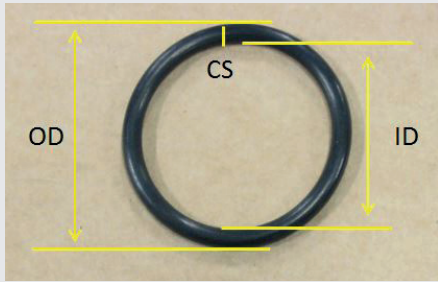
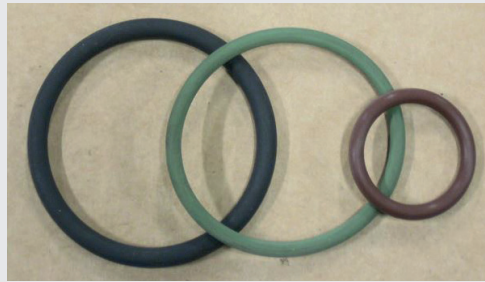
<p>Classic threaded fitting with gasket seal</p> 	<p>Radial seals</p> 
<p>O-ring description</p> 	<p>Colours: Some HARDI O-rings are made of Viton</p> 

O-rings and gaskets

To transport the liquid on a sprayer, the system needs tubes and hoses, fittings, O-rings and gaskets. The system should be leak-proof, easy to service, not restrict flow and, at the end of the spray job, have no residues left in it.

Face sealing method

The face seal is the classic sealing method. It usually consists of a threaded fitting and gasket or O-ring between the two surfaces. For a good seal, the surfaces have to be clean and it has to be tight. The settling or deforming of sealing material may require re-tightening at a later stage.

Radial sealing method

This is a better sealing method as it does not rely on tightness for a good seal and it normally does not require tools to connect or disconnect. Here the important factor is cleanliness. Lubrication of the O-ring at assembly is recommended.

O-ring and gasket description

The dimensions make the description of an O-ring, e.g. 150 x 140 x 5 SH70 Viton: Outer dimension (OD), internal dimension (ID), and thickness or cross section (CS). Sometimes the internal diameter is not given. Material hardness (Shore value) and material type are sometimes given at the end of the measurement description.

Hose types: Left, suction, middle and right, pressure



Hose clamps are all made of corrosion resistant material



Hoses and clamps

There are basically two types of hoses: suction hose which must resist collapsing under vacuum and pressure hose which must resist failure under pressure. The suction hose usually has a synthetic or metallic spiral of harder material inside the hose to prevent it from collapsing. The glossy HARDI suction hose is made from PVC with a synthetic white-coloured spiral. The HARDI pressure hose is usually a matt-coloured rubbery fibre-reinforced hose or a black glossy hose where the fibre reinforcement is more obvious.

The hoses usually have the following markings:

927xxx – This is the hose reference number per metre of hose.

BP – This stands for Burst Pressure. Work pressure is usually 1/3 if the burst pressure.

WP – This stands for Work Pressure.

They also have the hose batch number. This is extremely useful if we need to track hose of inferior quality.

HARDI metallic hose clamps are all made of stainless steel. Some of the smaller clamps are made of synthetic material. The material choice is to prevent corrosion of the clamps especially for the customers using the sprayer to spray liquid fertiliser.

All HARDI hose clamps are re-usable.

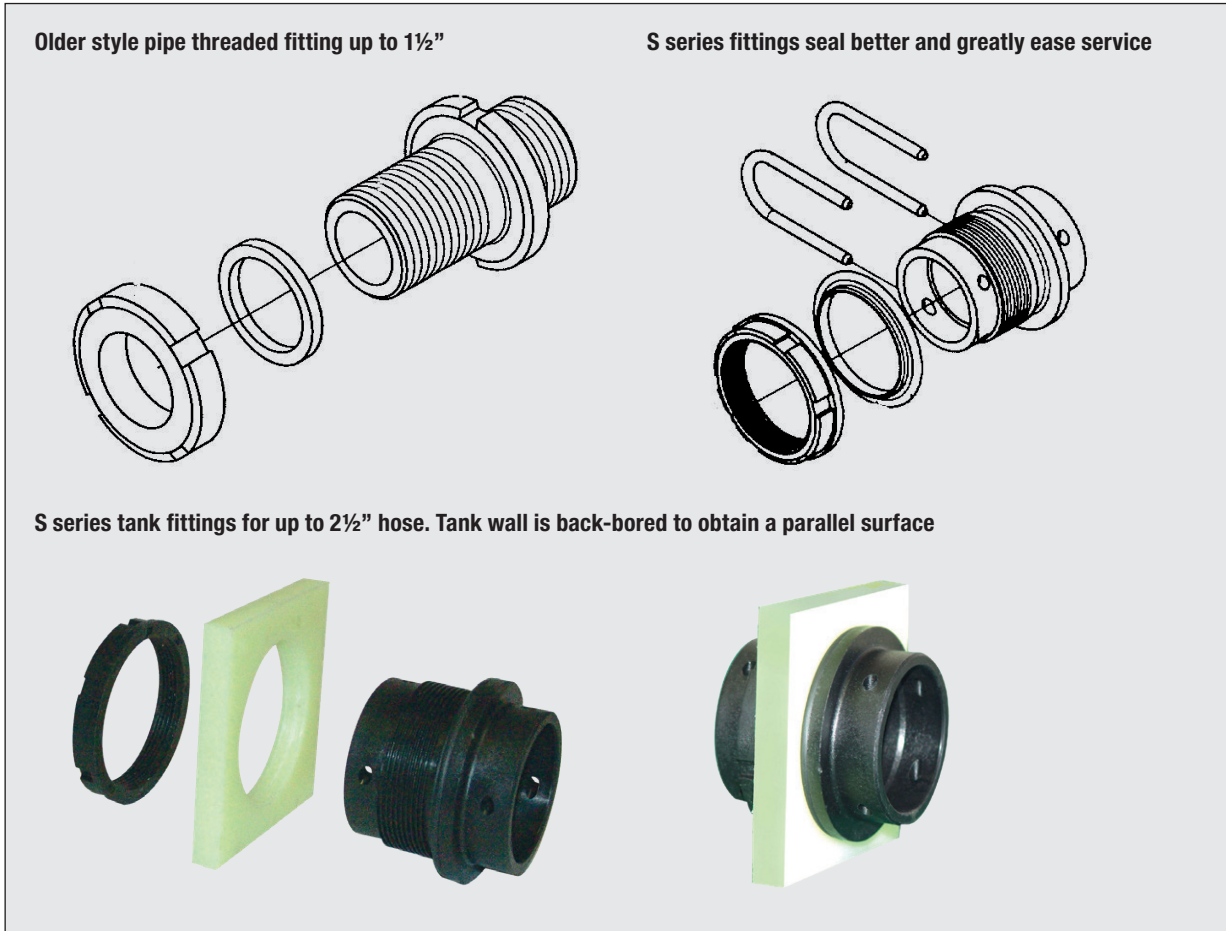

S-fittings for tanks and components

The classic fittings used on spraying equipment were basically taken from the plumbing industry that used face-seal technique and pipe or gas thread. Although readily available and cheap to buy, there are two main issues when used on sprayers being leakage once the seal material settles and service difficulty if dirt and dust fills the threads.

In the mid-80's HARDI introduced the S-series of tank and hose fittings, "S" standing for Saw Tooth, being the thread type. The S-fittings have a number of advantages:

- ▶ Service is quick and easy as they use a "U" pin to secure the fitting
- ▶ Sealing quality is excellent with the radial seal
- ▶ High flow capacity as internal restrictions are minimal

Large wall flanges can be difficult to seal especially if the wall thickness varies. Paste sealants are not a long-term solution. The HARDI tanks are back-bored to ensure the sealing surfaces are parallel and the S-fitting has a captive gasket to ease installation.

The S-fitting material is chemical and UV resistant (reinforced nylon) and the O-ring seals are made of highly chemical-resistant material. Working pressure is up to 15 bar (220 psi).

The radial seal system is now used by many spray equipment manufacturers.

HARDI D 22 series tubes and fittings

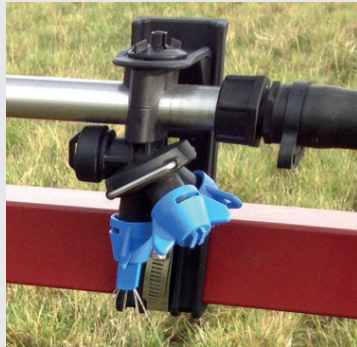

HARDI D-series with internal fittings



HARDI T22 & T25 tubes and fittings



HARDI T-series with external fittings and snap assembly



HARDI boom tubing systems

Before 1982, HARDI used PVC tubes with glued, face-sealing end-fittings for boom tubing. The introduction of the unique HARDI Diameter 22 polypropylene tubes with radial seal fittings and diaphragm non-drip nozzle check valves greatly improved the system.

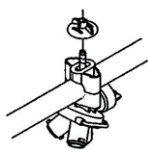

The nozzle body holders went from threaded fittings to single nozzle SNAP-FIT and then to SNAP-FIT TRIPLET that could carry three nozzles. This allows the operator select the best nozzles at point-of-spraying. QUADRILETS (4 nozzle) and PENTALETs (5 nozzle) along with a stainless steel tube option have also been added to the range.

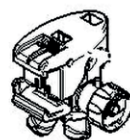

In 2013, HARDI again offered a unique Tube 25 and then later Tube 22 boom tube system. It offers easier and faster servicing as it is clicked together, a rail-mounted flexible positioning of nozzle holders and less residues yet higher capacity.

The fitting are connected externally on the boom tubes. This considerably reduces the pressure loss and improves the flow. They are designed so thick O-rings can be used to obtain best possible sealing.

To protect the nozzle holder bodies, the boom tubing system should always mounted inside or behind the boom profile





CHAPTER 13

Electrical equipment

HARDI Monitor from 1982 to 1985



HARDI TRONIC from 1985 to 1995



HARDI PILOT 3880 display from 1995 to 2003



HARDI NOVA from 2000 to 2005



HARDI spray computers

HARDI first started its humble beginnings with sprayer computers in 1978. In 1982, a new and popular computer monitor was introduced. It was called HARDI Monitor. With the need for a controller, the HARDI TRONIC 2000 along with a less costly monitor version called HARDI TRONIC 1800 were introduced in 1985. These units had two displays and the controller along with sprayer and hydraulic controls were incorporated into the same box.

Cabling was now bulky and there was a need for a bigger display, more sensors and the possibility to use positioning (GPS). The HARDI PILOT 3000 with data bus communication fulfilled the needs and was introduced in 1995. The original design incorporated a 5-position joystick but after field testing

in 1993, the design was dropped as the users did not find it intuitive. It kept the name but not the joystick.

With an increasing need to integrate the tractor and implement electronics, HARDI management decided to work with a known European supplier of agricultural electronics. In the late 90's, a partnership was set up with the German company, Müller Elektronik (ME) and the HARDI NOVA 4000 was introduced in the year 2000. The design was HARDI's responsibility but ME had the hardware and software responsibility. The German market worked with a national agricultural standard called LBS for electronic integration. This later went on to more or less become the ISO 11783 standard, now globally used for communication between tractor and implement.

HARDI Monitor 1500 and Controller 2500 from 1999 to 2013



HARDI Controller 5500 from 2002



HARDI Controller 6500 from 2005



HARDI Controller 8500 and 9500 from 2012



HARDI sprayer computers

At the end of the 90's, the market needed a low cost monitor and controller. Some of the software used on the HARDI PILOT was packed into a display that could be added to an existing control box. This range became known as the HM 1500 and the HC 2500. It was simple, low priced and could be added as a retro-fit. It became a popular HARDI computer and its life-span went on to become twice the originally planned time.

At the time of writing, the HARDI Controller (HC) range consists of three families:

HC 5500

It has the functionally designed "Swoosh box" from the HARDI NOVA and a 4-line display. The menu system has become the base for the next two families to simplify in-field serviceability by the dealer service staff.

HC 6500

It has a colour display, with a functionally designed primary (Grip) and secondary (SetBox) control unit. Communication is CAN data bus to simplify cabling.

HC 9500 and HC 8500

With the need to integrate auto section control, automatic boom management, ISO compatibility, automatic steering of the self-propelled sprayers and more spray job documentation, HARDI set up a partnership with Ag Leader from the USA. These units run HARDI software and have touch sensitive screens along with a USB port for data transfer. The current versions are called HC 9600 and HC 8600.

Location from front pillar



Rear pillar location



Screen and box separation



Primary and secondary functions with Grip and SetBox



HARDI sprayer computers

Functional design has played a great part in the layout of boxes and screens of HARDI controls and computers. With the realisation that the tractor is moving, sunlight makes it difficult to see the screen and the cabin space is limited, the well-thought-out modular design, box shapes and screen layout contributes to the ease of use.

The primary control can be placed close to the operator as it has the most used functions. Secondary functions like folding and unfolding can be placed further away. The rounded right-hand side of the boxes allows the operator to steady his palm on the box and use his thumb to press buttons. The screen can be placed at the front so the operation does not have to take his eye away from the line of travel and the most important screen items are large and easy to see.

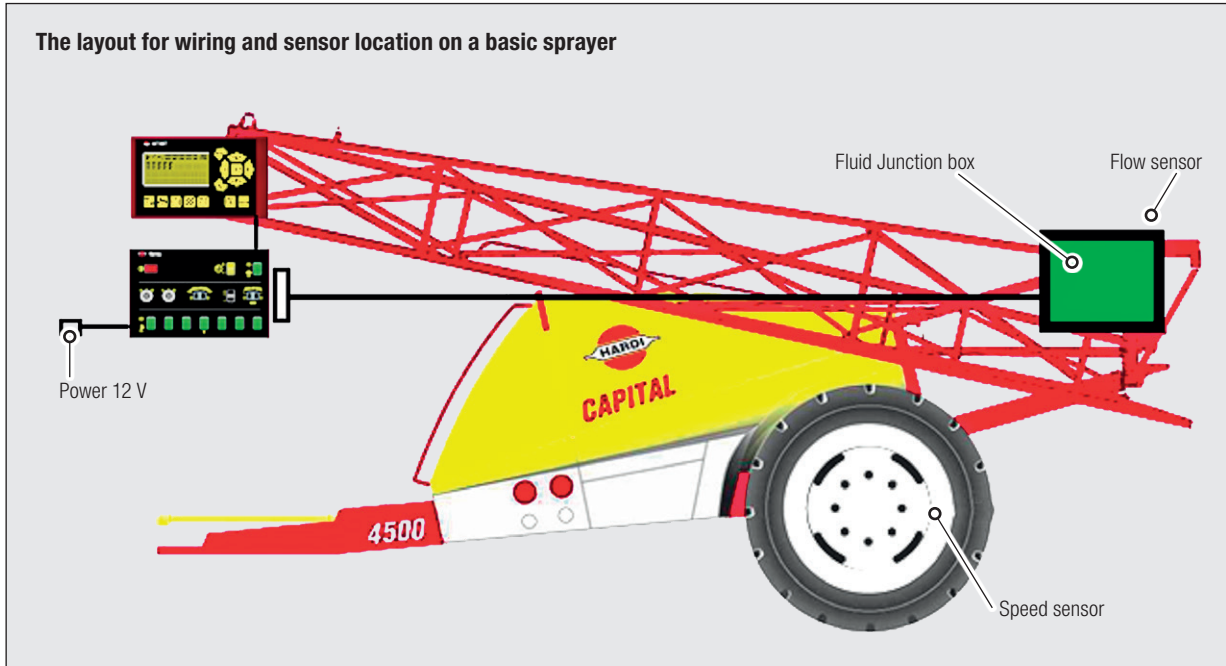

Monitor and Controller basics

The initial task of the first electronics on sprayers was to help the operator keep the desired application rate at different speeds. In the past 15 years, sprayer electronics have had incredible growth to meet the increasing demands but the basics are still the same. The basic input to be keyed in is boom size, number of nozzles and sections. Basic sensor input is for speed and flow or pressure. The speed and flow sensors give a signal (or current) and typically need to be calibrated so the signal can relate to a value.

A typically used speed sensor gives a pulse signal. In early systems, a 2-wire technique called “reed switch” was used where a magnet passing by the sensor would cause the metallic reed to close a circuit and allow current to flow. As they were prone to mechanical failure, induction sensors with a 3-wire system, power, earth and signal, and no moving parts became popular. With 12 Volt power, they typically give a 6 Volt signal.

At calibration, the computer logs a number of signals. The operator then relates this to the physically measured value. E.g. 500 pulses are logged over 100 metre. The computer now calculates that for every 5 pulses, this is equal to 1 metre. Well calibrated sensors are important.

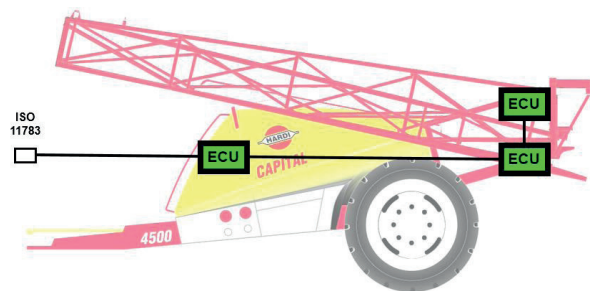

ISO compatible sprayer layout showing three Electronic Control Units.

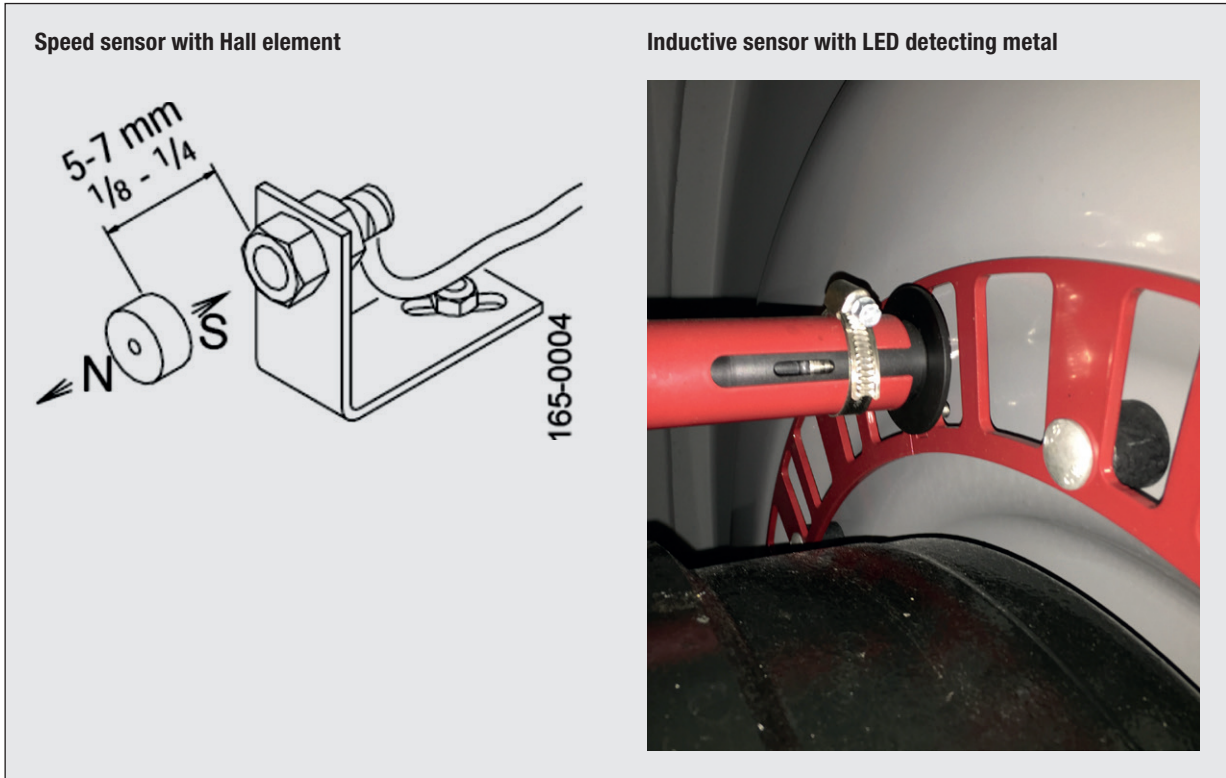

Speed sensors

Hall Element

Some sensors need a magnet to generate a signal. They use a solid state Hall Element that can detect the south pole of the magnet. It will not detect the north pole. Magnets used will be stamped with an "S" or colour-coded to indicate the south pole.

Inductive sensors

This sensor type is very common as they typically can detect metal and can be supplied with a LED to aid in fault-finding. The distance from sensor to metal is 4 to 8 mm.

The metallic ring on trailed HARDI sprayers has gaps with varying distances. This is used to determine whether the sprayer is travelling forwards or reversing.

HARDI has used AMP SuperSeal connectors for many years to allow quick and easy servicing.

Colour-coding

Colour	Pole	AMP SuperSeal pin
Brown	+	2
Blue	Signal	3
Black	-	1

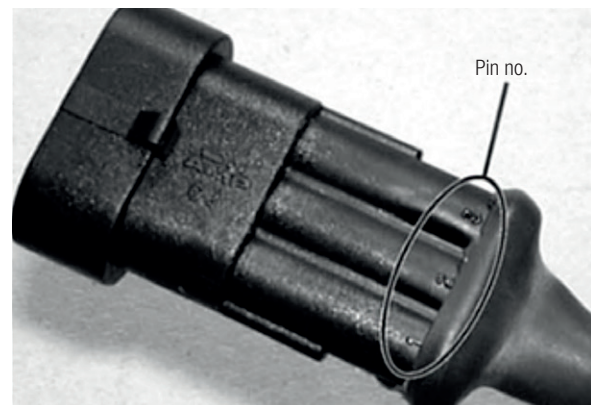

Flow housing and flow sensor showing LED at top



Flow sensor with rotor at bottom

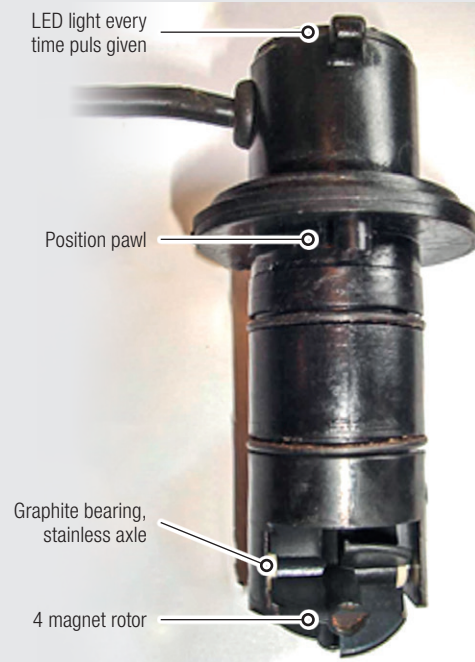

Flow sensor

The nozzle output can be detected by a pressure or flow sensor. The classic sensor in the HARDI liquid system is the flow sensor which has magnets on a rotor that is turned by the flow of liquid. The early 2-wire system generated a current. The present more reliable system has a Hall Element and produces a 6 Volt signal.

The flow sensor must be located so it only meters the liquid going to the nozzles. The flow sensor needs enough flow for it to give a reliable signal. If it turns slowly, it will not give a steady signal. The housing orifice is sized to produce good signal quality. The specification of the housing will state the optimum work range.

If instead a pressure sensor is used to detect output, it needs to be located in the boom sections' manifold so if some sections are closed, the sensor can still detect pressure at the open nozzles.

The DynamicFluid4 systems uses both flow and pressure signal for a reliable signal at low nozzle output and to allow "limp home" capability should one of the sensor be damaged.



House orifice	Flow range	ID ring
6 mm	3 - 70 l/min	3
13.5 mm	5 - 150 l/min	1
20 mm	10 - 300 l/min	0
36 mm	35 - 600 l/min	2

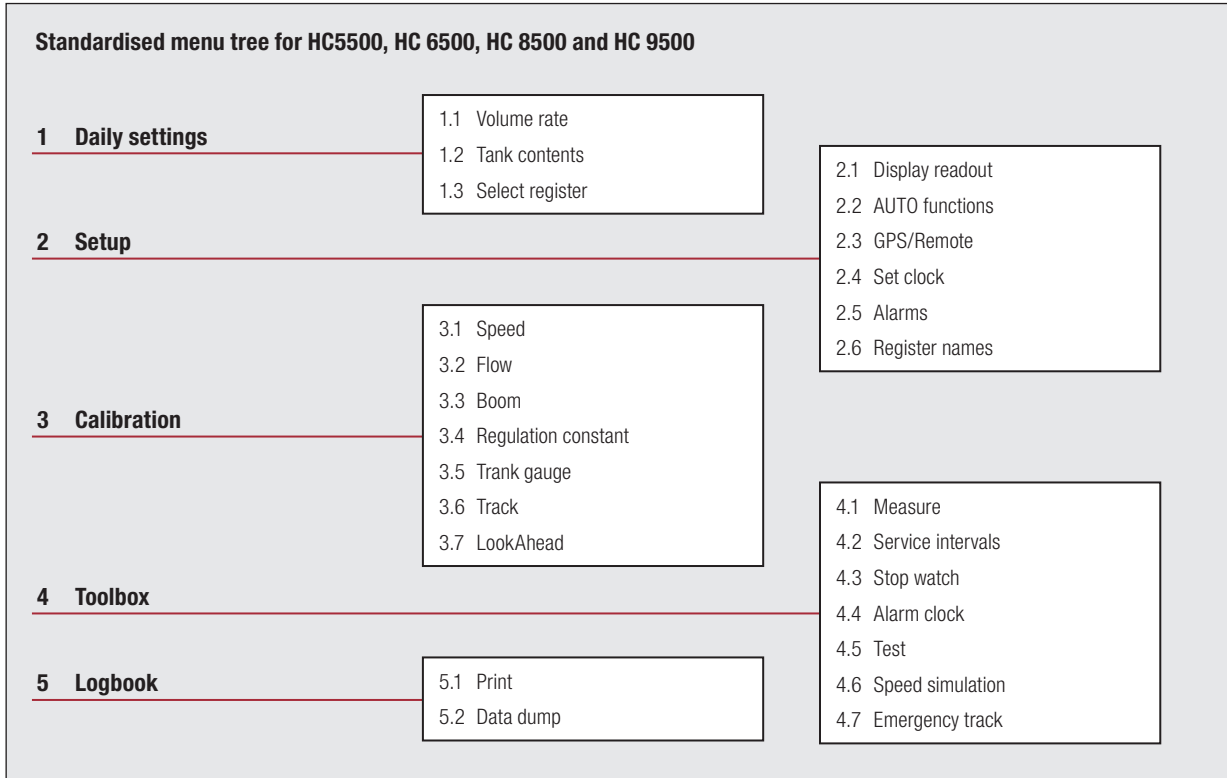

Computer menu tree

The menu layout for many of the HARDI computers is the same. This simplifies help to the operator when he rings the service staff for help.

The settings the operator often needs to attend to like application rate and actual tank contents are all placed at the first menu item he meets. Usually it is “Enter, enter, enter” to each menu point to change application rate.

The menu points also have an identification number to ease over the phone service. For example, to change application rate, go to menu point 1.1.1.

Pressing or holding the Escape button will bring you back to the work screen.



CHAPTER 14

Fault-finding

Before you go...

SERVICE BULLETIN

SB15 - 021 Date: 22.04.2015

At earliest convenience

Ref.: TurboFiller manifold leakages

Machines affected:
Navigator from 2012 sup. and forward

Problem:
Internal leakage and external leakages in the TurboFiller manifold occurs after short time of use.

Probable cause:
The internal leakage is caused by use of wrong plastic raw material. The symptom of the deformed plastic fitting is fluid leaking into the TurboFiller bowl. The plastic fitting moves away from the valve seat and the valve will therefore start to leak.

External leakage
The external leakage appears in the valve units operating different function on the TurboFiller manifold. This problem is caused by renovation of the plastic moulding form. The plastic housing for the valve unit were made too large so the O-ring can't seal between housing and valve, after a few operations does the valve start to leakage.

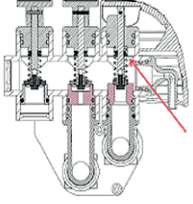

Remedy:
To solve the problems is the manifold replace with a new and stronger manifold. The parts needs for upgrading Navigator TurboFiller.

- 1 pos 72482000 comp. manifold
- 1 pos 33512800 90 degree S25 fitting L38
- 1 pos 33512900 90 degree S25 fitting L60
- 1 pos 33512500 Hose fitting 90 degrees hose to handgun
- 1 pos 33512500 Hose fitting 90 degrees hose for ejector
- 1 pos 335561 90 degree Hose fitting 1" S25 hose for manifold
- 5 pos 240951 O-ring 21,2 X 3 Nitril

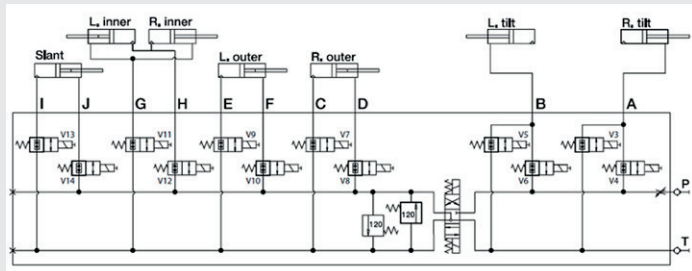
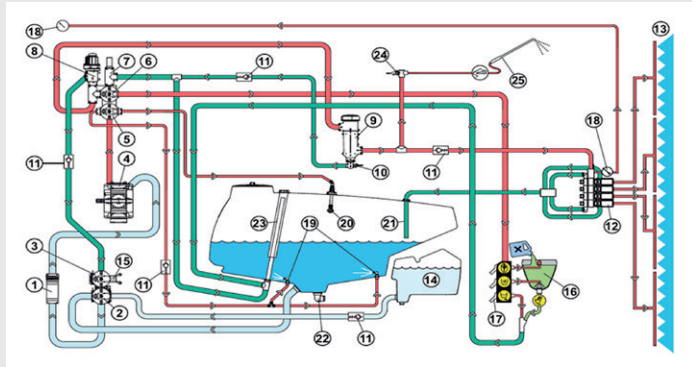

Basic Tools

Effective fault-finding is a combination of experience, logic and luck. No single tool will be the key to effective fault-finding but I trust the following may be of help.

Before you go...

- 1 Find the documentation and understand how the system should function. The instruction book is often a good source of liquid and hydraulic system documentation. Service manuals exist for the electronic systems.
- 2 Check the Service Bulletins for relevant information.
- 3 Ensure you have the latest software updates with you.

Have a good power distribution box with you if you suspect a poor power supply. The cables must be thick to supply the amperage.

Make sure the connections go directly to the battery. Connection to the starter solenoid and engine block will eventually destroy most implement computers.



Plugs and tees to isolate liquid lines



Gauges to test hydraulic pressure



Connector breakout and Multi-meter



Magnet indicator



The Toolbox

Below are some handy tools to have in the toolbox.

- 1 For the spray liquid, plugs and Tees to isolate parts of the system.
- 2 For hydraulics, gauges to check pressure.
- 3 For electrics and electronics, connector breakouts
- 4 A multi-meter, preferably with frequency readout.
- 5 For checking solenoid valves, a magnetic indicator.

See the problem

When at the sprayer, ask the customer to show you exactly what the problem is. This can be challenging with periodic electrical faults. Once the problem is defined, then you can tackle it.

Use logic. With a problem in the liquid system, start with the suction line/hose from the tank to the pump. With electrical problems, start with the power supply (battery).





CHAPTER 15

Identification



Reference number logic

Item Section	Description
1 XXXXXXX	Cast/forged and machined items (metals)
2 XXXXXXX	Purchased finished and machined goods (except plastics)
3 XXXXXXX	Plastic items (moulded and machined items)
4 XXXXXXX	Purchased screw fasteners etc.
5 XXXXXXX	HARDI surface treatment standards (internal use only)
6 XXXXXXX	Inseparable assemblies
7 XXXXXXX	Subassemblies
8 XXXXXXX	Sales items at family/element/component level
9 XXXXXXX	Raw materials

Last two digits indicate the engineering site

XXXXXX 00	HIA, HARDI INTERNATIONAL A/S, Denmark
XXXXXX 01	HAE, HARDI-EVRARD, France
XXXXXX 02	IHS, ILEMO HARDI, Spain
XXXXXX 03	HIN, HARDI INC., North America
XXXXXX 04	HAU, HARDI AUSTRALIA, Australia
XXXXXX 05	HUK, HARDI UK, Great Britain
XXXXXX 06	HAG, HARDI GmbH, Germany
XXXXXX 07	EXEL-gsa, France

Parts numbers logic

The HARDI reference numbers have a structured logic. The first of the above tables shows the first level division. A purchased item like a ball bearing would start with "2" and all synthetic parts moulded by HARDI would start with "3". The second digit also has logic. Knowing the above basic logic may identify incorrect reference numbers.

The original numbering system only had 4 digits. The present system has 6 and 8 digits. All numbers now generated have 8 digits. The last 2 digits indicate the engineering site.

Synthetic cylinder for hand-operated pump: C indicates the 4th version

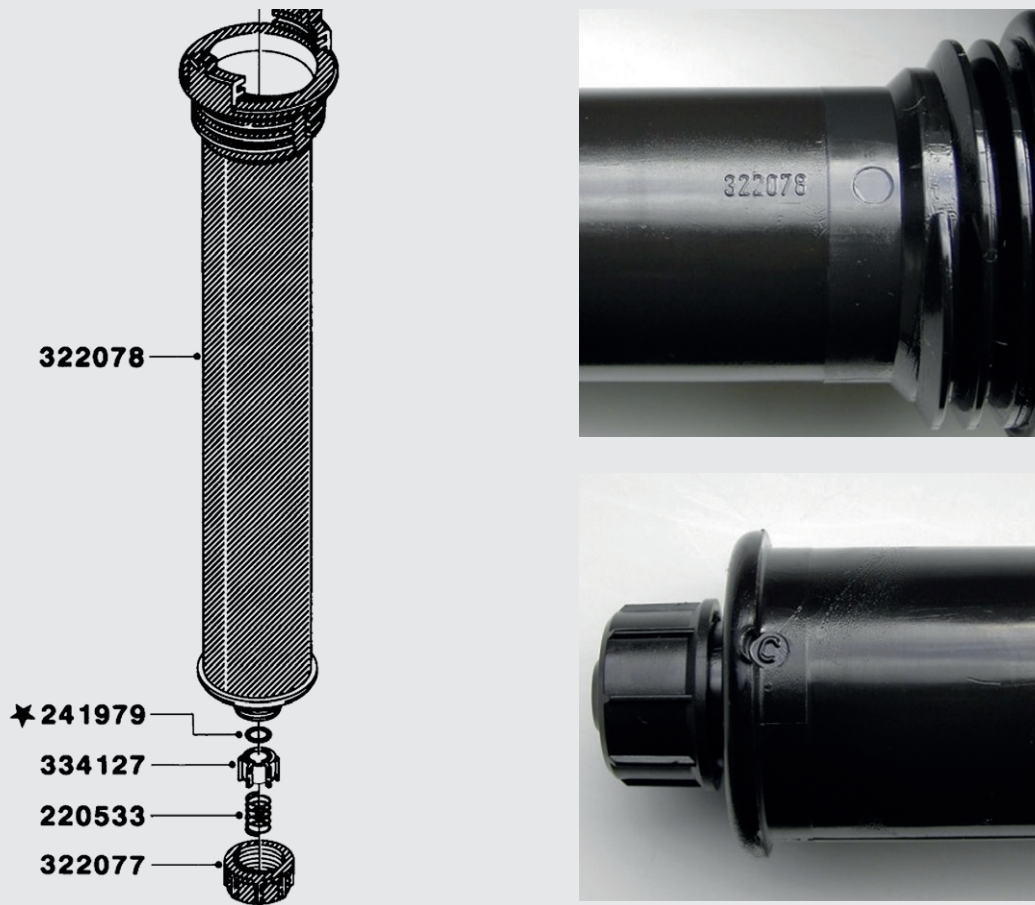

Parts number version identification

It is at times very difficult to identify components that have been improved. If a synthetic component has had an improvement, it is usually identified in two ways; either by an addition of a mark or by a change of colour.

The above component has had the letter "C" moulded into it. It is the 4th variant. Preceding components with no lettering or the letters "A" or "B" are older versions.

Colour change is another possibility to identify newer component versions.

Technical Service bulletins are a good source of information on product updates and how to identify old and new components.



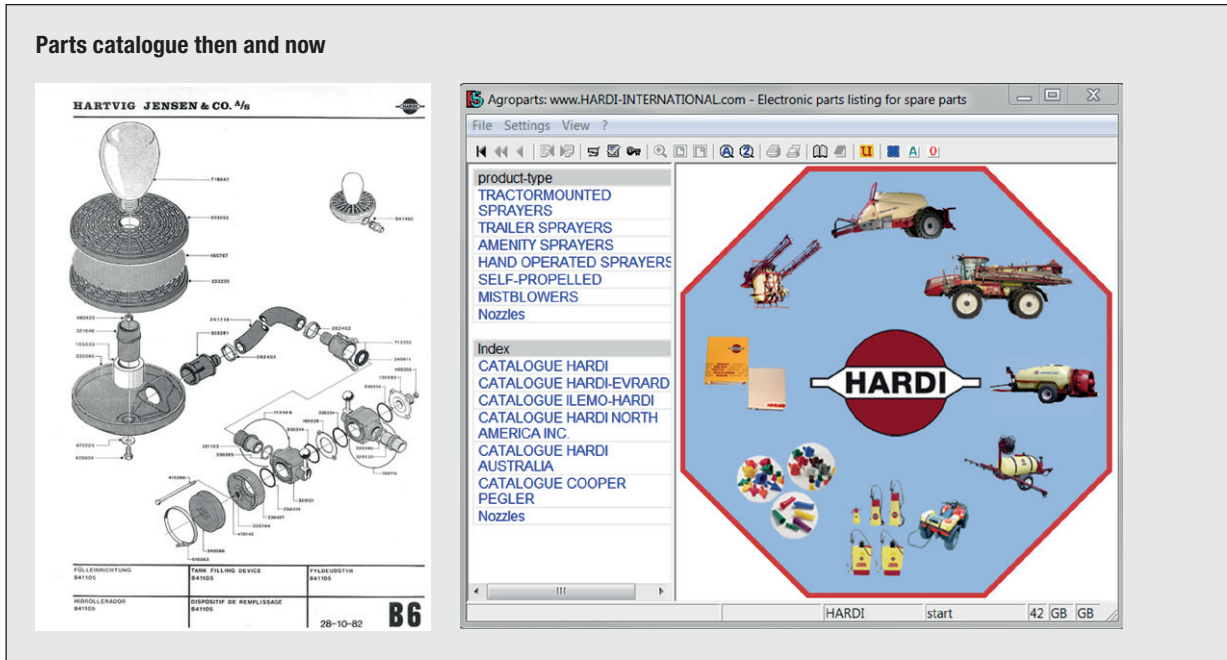

HARDI Parts Catalogue

The divisions of the HARDI Parts Catalogue are listed below. The catalogue started life as a paper version under the original company name of "Hartvig Jensen & Co. A/S". Today it is only available in a digital format.















- ▶ Pumps, Pump fittings, Overviews
- ▶ Control units, Filters, Pulsation dampers, Valves, Hoses, Nozzles
- ▶ Hydraulics
- ▶ Booms, Feed pipes
- ▶ Tanks / Frames: Field sprayers
- ▶ Tanks / Frames: Mistblowers
- ▶ Blower unit Mistblowers
- ▶ Motorized & 12 Volt sprayers
- ▶ Hand-operated sprayers & equipment
- ▶ Special equipment, Extras, Transmission shafts, Components
- ▶ Fittings, Feed pipe fittings
- ▶ Electrical equipment, Cabling, Sensors, Electronics overview

The HARDI Electronic Parts Catalogue can be found in two digital versions.

The professional HARDI support version needs to be purchased.

The customer version is free and found on the internet under www.agroparts.com

Symbols

 Suction from main tank	 Pressure to filling	 Pressure to empty	 Pressure to rinse tank	 Pesticide transfer empty
 Suction from rinse Tank	 Pressure to nozzles	 Pressure to agitation	 Pesticide container flush	 Pesticide from external source
 Suction from nurse tank	 Pressure to rinse nozzles	 Pressure to external clean	 Pesticide transfer agitation	

Symbols

The general rule for the HARDI liquid diagram colour-coding is:

- ▶ **Blue** is the suction side
- ▶ **Green** is the pressure side. This may include low pressure return lines
- ▶ **Yellow** for pesticide transfer equipment

The same coding is used with icons to help identify the function. The simplified icons present a good overview of the work area as it is not cluttered with text. The above table shows the most used icons.

Lift mounted

The following identification tables are based on the models previously produced at the main plant in Denmark. Some model names are still in the current product range but may have different specifications.

There will be variations on naming and production start stop dates of models sold in North America and Australia.

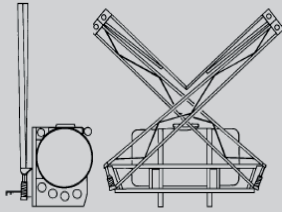
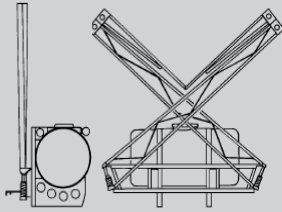
Name		BL	
Name origin	"Beholder Liggende" (Danish for "Tank lying down")		
Production start	1977		
Production stop	2004		
Tank size (litre)	200, 300		
Notes	Barrel shaped tank. Pump usually fitted directly to the tractor P.T.O. Equipped with M-70 control unit. The variant for the amenity market is called JAZZ with a BK control unit.		
			
Boom size (m)	6, 8	6, 8	
Boom name	ST	SB	
Name origin	Standard Boom	Small Boom	
Production start	1966	1982	
Production stop	1982	In production	
Notes	Manually cross folded. Breakaway has spring inside the cast iron housing.	Manually cross folded. Breakaway spring tension is adjustable. Originally with 3/8" nozzle cap.	

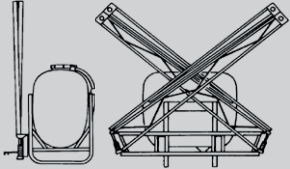
Name		NL	
Name origin	Variant between NK and BL (NL)		
Production start	1988		
Production stop	2004		
Tank size (litre)	300, 400, 600, 800		
Notes	Fitted with M-70 control unit and 2 or 3 boom section valves.		
			
Boom size (m)	6, 8, 10, 12		
Boom name	SB		
Name origin	Small Boom		
Production start	1982		
Production stop	In production		
Notes	Manually cross folded. Breakaway spring tension is adjustable. Originally with 3/8" nozzle cap.		

Lift mounted

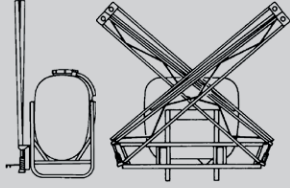
Name		NK	
Name origin	"Ny Kuffert" (Danish for new suitcase)		
Production start	1971		
Production stop	In production		
Tank size (litre)	300, 400, 600, 800		
Notes	Fitted with BK control unit. Barrel shaped 200 litre (previously called BL) added to NK range in 2004.		
			
Boom size (m)	6, 8, 10, 12		
Boom name	SB		
Name origin	Small Boom		
Production start	1982		
Production stop	In production		
Notes	Manually cross folded. Breakaway spring tension is adjustable. Originally with 3/8" nozzle cap.		

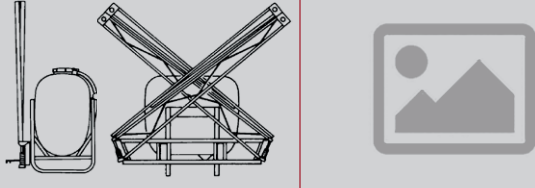
Name		NV	
Name origin	NK variant with trapeze suspended booms.		
Production start	1997		
Production stop	2004		
Tank size (litre)	600, 800		
Notes	Fitted with BK control unit.		
			
Boom size (m)	10, 12	12, 12.5, 15	
Boom name	MB	HFM	
Name origin	Medium Boom	Horizontal Fold Manual	
Production start	1982	1997	
Production stop	Inroduction	2004	
Notes	Manually cross folded. Trapeze suspension. Inner/outer sections have a stainless steel lock.	Manually folded horizontally behind the tank. Trapeze suspension.	

Lift mounted

Name		NX	
Name origin	Variant of NK and LX.		
Production start	1992		
Production stop	1993		
Tank size (litre)	600, 800, 1000, 1200		
Notes	Fitted with BK control unit.		
			
Boom size (m)	10, 12.5, 15		
Boom name	HFA		
Name origin	Horizontal Fold A version		
Production start	1991		
Production stop	1997		
Notes	Boom lift function is hydraulic. Manually folded horizontally behind the tank. Pendulum suspension.		

Name		NY	
Name origin	Variant of NK and LY.		
Production start	1995		
Production stop	1997		
Tank size (litre)	600, 800, 1000, 1200		
Notes	Fitted with BK control unit.		
			
Boom size (m)	10, 12.5, 15		
Boom name	HFY		
Name origin	Horizontal Fold Y version		
Production start	1995		
Production stop	2002		
Notes	Boom lift function is hydraulic. Hydraulic horizontal fold behind the tank. Pendulum suspension.		

Lift mounted

Name		LX	
Name origin	Lift mounted with hydraulic boom lift and manual boom fold.		
Production start	1982		
Production stop	1994		
Tank size (litre)	600, 800, 1000, 1200		
Notes	Fitted with manual BK control unit. Tanks before 1988 are oval in shape. Tanks after 1988 are rectangular in shape except for 600 litre.		
Boom size (m)	10, 12, 15	12, 15, 16, 18	
Boom name	MB	HB	
Name origin	Medium Boom	Heavy Boom	
Production start	1982	1985	
Production stop	15m stopped in 1986.		
Notes	Hydraulic boom lift. Manually cross folded. Trapeze suspension.	Manually folded. Hinged on centre section.	

Name		LY	
Name origin	Lift mounted with hydraulic boom lift and fold.		
Production start	1982		
Production stop	1994		
Tank size (litre)	600, 800, 1000, 1200		
Notes	Tanks before 1988 are oval in shape. Tanks after 1988 are rectangular in shape except for 600 litre. Self Cleaning filter standard.		
Boom size (m)	12	12, 15	12, 15
Boom name	HY	HYA	HYB
Name origin	Hydraulic ("Seagull wing")	Hydraulic A version ("Seagull wing")	Hydraulic B version ("Seagull wing")
Production start	1982	1988	1991
Production stop	1988	1991	2001
Notes	Hydraulic boom lift and fold. Trapeze suspension. TRIPLET nozzle holders standard.	Strengthened version of HY. Lowest centre section step is nearly as wide as upper step.	Different to HYA in that the breakaway functions in both forward and back direction.
Boom size (m)	12, 15, 16, 18		
Boom name	LHY		
Name origin	Light Hydraulic Y version		
Production start	1982		
Production stop	1998		
Notes	Hydraulic boom lift and fold. Trapeze suspension.		

Lift mounted

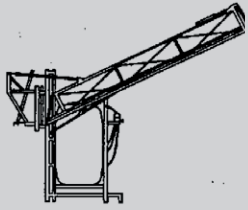
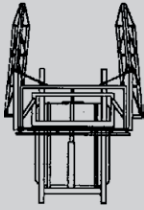
Name		LZ	
Name origin	Lift mounted with electric controlled hydraulic boom lift and fold.		
Production start	1982		
Production stop	1996		
Tank size (litre)	800, 1000, 1200		
Notes	Fitted with electric EC control unit. Tanks before 1988 are oval in shape. Tanks after 1988 are rectangular in shape. Self Cleaning filter standard.		
			
Boom size (m)	12, 15, 16, 18, 20, 21, 24		
Boom name	LHZ		
Name origin	Light Hydraulic Z version		
Production start	1982		
Production stop	1998		
Notes	Electricly controlled hydraulic boom lift, fold, slant, tilt and fold of outer sections only. Trapeze suspension. TRIPLET nozzle holders standard.		

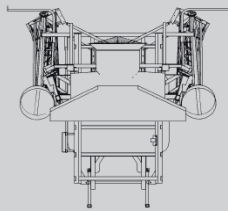
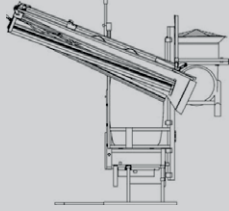
Name		LA	
Name origin	Lift mounted with air-assisted hydraulic boom.		
Production start	1988		
Production stop	1995		
Tank size (litre)	800, 1000, 1200		
Notes	Fitted with electric EC control unit. Tank has a rectangular shape. Self Cleaning filter standard.		
			
Boom size (m)	12, 15, 16, 18		
Boom name	HAB		
Name origin	Hydraulic Air-assisted Boom		
Production start	1988		
Production stop	1998		
Notes	Self contained hydraulic system to power single blower for air assisted boom. Electricly controlled hydraulic lift, fold, slant, tilt and fold of outer sections only. Trapeze suspension.		

Lift mounted

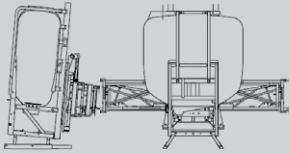
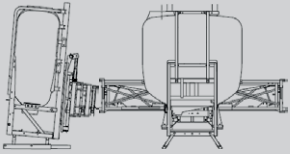
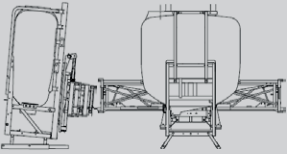
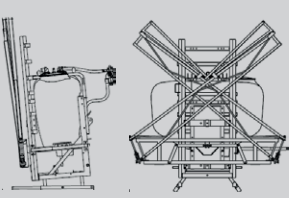
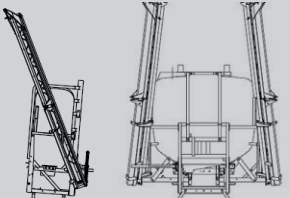
Name		MA		
Name origin	MASTER			
Production start	1994			
Production stop	In production			
Tank size (litre)	800, 1000, 1200			
Notes	Filling hole to right side. Fitted with manual BK or electric EVC control unit. Self Cleaning filter standard.			
				
Boom size (m)	12, 12.5, 15	10, 12, 12.5, 15	10, 12, 12.5, 15	
Boom name	HFM	HFA	HFY	
Name origin	Horizontal Fold Manual	Horizontal Fold A version	Horizontal Fold Y version	
Production start	1982	1991	1995	
Production stop	2004	1997	2002	
Notes	Hydraulic lift. Trapeze suspension.	Hydraulic lift. Pendulum suspension.	Hydraulic lift and fold. Pendulum suspension.	
				
Boom size (m)	10, 12	12, 15		
Boom name	MB	HYB		
Name origin	Medium Boom	Hydraulic B version ("Seagull wing")		
Production start	1982	1991		
Production stop	In production	2001		
Notes	Hydraulic boom lift. Manually cross folded. Trapeze suspension. Inner/outer sections have a stainless steel lock.	Different to HYA in that the breakaway functions in both forward and back direction.		

Lift mounted

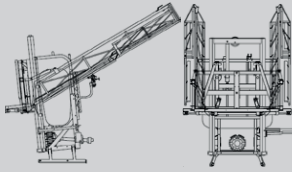
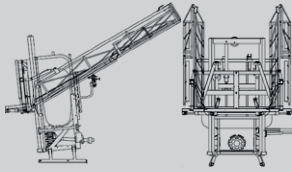
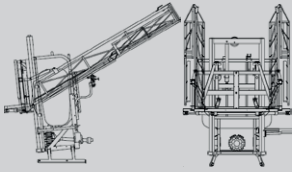
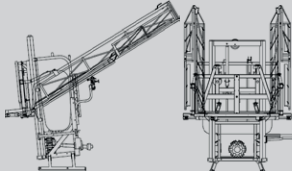
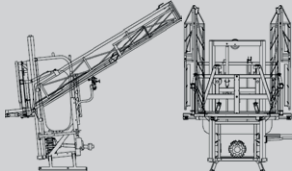
Name		ME		
Name origin	MEGA			
Production start	1998			
Production stop	In production			
Tank size (litre)	800, 1000, 1200			
Notes	Filling hole to right side. Fitted with electric EVC control unit. Self Cleaning filter standard.			
				
Boom size (m)	12, 15, 16, 18	12, 15, 16, 18, 20, 21, 24	15, 16, 18	
Boom name	LHY	LHZ	LPY	
Name origin	Light Hydraulic Y version	Light Hydraulic Z version	Light Pendulum Y version	
Production start	1992	1992	1998	
Production stop	1998	1998	2008	
Notes	Hydraulic boom lift and fold. Trapeze suspension. TRIPLET nozzle holders standard.	Electricly controlled hydraulic boom lift, fold, slant, tilt and fold of outer sections only. Trapeze suspension. TRIPLET nozzle holders standard.	Hydraulic boom lift and fold. Pendulum suspension. TRIPLET nozzle holders standard.	
				
Boom size (m)	15, 16, 18, 20, 21, 24	15, 16, 18, 20, 21, 24		
Boom name	LPZ	LPV		
Name origin	Light Pendulum Z version	Light Pendulum V version		
Production start	1998	1998		
Production stop	2008	2004		
Notes	Electricly controlled hydraulic boom lift, fold, slant, tilt and fold of outer sections only. Pendulum suspension. TRIPLET nozzle holders standard.	Electricly controlled hydraulic boom lift, fold, slant and fold of outer sections only. (No tilt function) Pendulum suspension. TRIPLET nozzle holders standard.		

Trailed

The following identification tables are based on the models previously produced at the main plant in Denmark. Some model names are still in the current product range but may have different specifications.

There will be variations on naming and production start stop dates of models sold in North America and Australia.

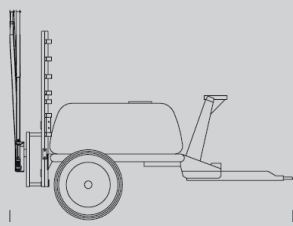
Name		TR	
Name origin	Trailed sprayer with hydraulic boom lift and manual fold.		
Production start	1995		
Production stop	1999		
Tank size (litre)	1000, 1400		
Notes	Breadloaf shaped tank supported on large diameter tube. Adjustable axle width.		
			
Boom size (m)	10, 12, 15		
Boom name	MB		
Name origin	Medium Boom		
Production start	1982		
Production stop	15m stopped in 1986.		
Notes	Hydraulic boom lift. Manually cross folded. Trapeze suspension. Inner/outer sections have a stainless steel lock.		

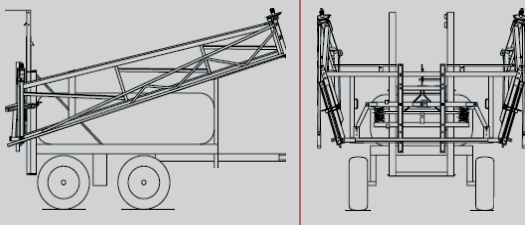
Name		TR 2000	
Name origin	Trailed sprayer 2000 litre series with hydraulic boom lift.		
Production start	2000		
Production stop	2006		
Tank size (litre)	2000		
Notes	Oval shaped tank supported on "C" profile channels. Single and tandem axle option.		
			
Boom size (m)	13.5, 15, 18, 20, 21		
Boom name	SPB		
Name origin	Spring suspended B version		
Production start	1996		
Production stop	In production		
Notes	Trapeze suspension arms supported by coil springs. Hydraulic boom lift. Manual and hydraulic fold version.		

Trailed

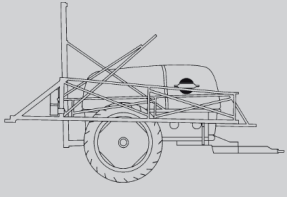
Name		TX	
Name origin	Trailed sprayer with hydraulic boom lift and manual boom fold.		
Production start	1982		
Production stop	1996		
Tank size (litre)	1500, 2400		
Notes	Breadloaf shaped tank supported in deep frame.		
			
Boom size (m)	12, 15, 16, 18		
Boom name	SPA		
Name origin	Spring suspended A version		
Production start	1989		
Production stop	1997		
Notes	Trapeze suspension arms supported by two coil springs. Hydraulic boom lift. Manual fold along side of tank.		

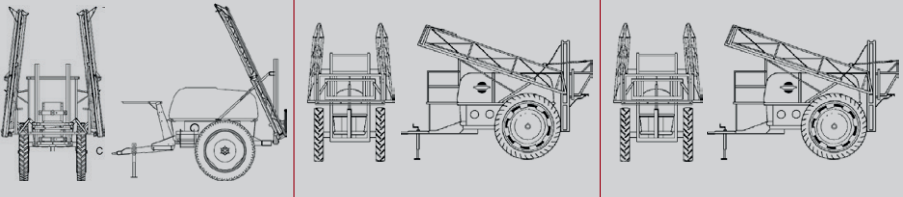
Name		TY		
Name origin	Trailed sprayer with hydraulic boom lift and boom fold.			
Production start	1982			
Production stop	1996			
Tank size (litre)	1500, 2400, 3500			
Notes	Breadloaf shaped tank supported in deep frame.			
				
Boom size (m)	12, 15	12, 15, 16, 18	20, 21, 24, 28	
Boom name	HYB	LHY	MHY	
Name origin	Hydraulic B version ("Seagull wing")	Light Hydraulic Y version	Medium Hydraulic Y version	
Production start	1991	1982	1989	
Production stop	2001	1998	2000	
Notes	The breakaway functions in both forward and back direction. TRIPLET nozzle holders standard.	Hydraulic boom lift and fold. Trapeze suspension. TRIPLET nozzle holders standard.	Hydraulic boom lift and fold. Trapeze suspension. TRIPLET nozzle holders standard.	

Trailed

Name		TZ		
Name origin	Trailed sprayer with electric controlled hydraulic boom lift and fold.			
Production start	1982			
Production stop	1996			
Tank size (litre)	1500, 2400, 3500			
Notes	Breadloaf shaped tank supported in deep frame.			
Boom size (m)	12, 15, 16, 18, 20, 21, 24	20, 21, 24, 28	18, 20, 21, 24, 27, 28	
Boom name	LHZ	MHZ	OLH	
Name origin	Light Hydraulic Z version	Medium Hydraulic Z version	Olympic HARDI	
Production start	1982	1989	1994	
Production stop	1998	2000	2001	
Notes	Electricly controlled hydraulic boom lift, fold, slant, tilt and fold of outer sections only. Trapeze suspension. TRIPLET nozzle holders standard.	Electricly controlled hydraulic boom lift, fold, slant, tilt and fold of outer sections only. Trapeze suspension. TRIPLET nozzle holders standard.	Electricly controlled hydraulic boom lift, fold, slant, tilt and fold. Pendulum suspension. TRIPLET nozzle holders standard.	

Name		TA		
Name origin	Trailed air assisted sprayer with electric controlled hydraulic boom lift & fold.			
Production start	1989			
Production stop	1996			
Tank size (litre)	1500, 2400, 3500			
Notes	Breadloaf shaped tank supported in deep frame.			
Boom size (m)	12, 15, 16, 18	18, 20, 21, 24		
Boom name	HAB	HAC		
Name origin	Hydraulic Air-assisted Boom	Hydraulic Air-assisted Boom		
Production start	1988	1992		
Production stop	1998	1997		
Notes	Self contained hydraulic system to power single blower for air assisted boom. Electricly controlled hydraulic lift, fold, slant, tilt and fold of outer sections only. Trapeze suspension. TRIPLET nozzle holders standard.	Self contained hydraulic system to power single blower for air assisted boom. Electricly controlled hydraulic lift, fold, slant, tilt and fold of outer sections only. Trapeze suspension. TRIPLET nozzle holders standard. Cables from centre section help support the boom wings.		

Trailed

Name			
COMMANDER			
Name origin	New name series		
Production start	1996		
Production stop	2000		
Tank size (litre)	2200, (2600), 2800, 3200, 4200		
Notes	Drawbar bolted to tank frame.		
Boom size (m)	12, 15, 16, 18	12, 15, 16, 18, 20, 21, 24	18, 20, 21, 24, 27, 28
Boom name	LHY	LHZ	OLH
Name origin	Light Hydraulic Y version	Light Hydraulic Z version	Olympic HARDI
Production start	1982	1982	1994
Production stop	1998	1998	2001
Notes	Hydraulic boom lift and fold. Trapeze suspension. TRIPLET nozzle holders standard.	Electricly controlled hydraulic boom lift, fold, slant, tilt and fold of outer sections only. Trapeze suspension. TRIPLET nozzle holders standard.	Electricly controlled hydraulic boom lift, fold, slant, tilt and fold. Pendulum suspension. TRIPLET nozzle holders standard.
Boom size (m)	18, 20, 21, 24, 27, 28	18, 20, 21, 24, 27, 28	20, 21, 24, 28
Boom name	OLS	OLV	MHY
Name origin	Olympic S version	Olympic V version	Medium Hydraulic Y version
Production start	1994	1994	1989
Production stop	2001	2001	2000
Notes	Hydraulic boom lift, fold, tilt, slant and fold. Hydraulics are indirect (switch and lever). Pendulum suspension. TRIPLET nozzle holders standard.	Electricly controlled hydraulic boom lift, fold, slant and fold. Pendulum suspension. TRIPLET nozzle holders standard.	Hydraulic boom lift and fold. Trapeze suspension. TRIPLET nozzle holders standard.
Boom size (m)	12, 15, 16, 18	18, 20, 21, 24	18, 20, 21, 24, 27, 28
Boom name	HAB	HAC	HAY (TWIN FORCE)
Name origin	Hydraulic Air-assisted B version	Hydraulic Air-assisted C version	Hydraulic Air-assisted Y version
Production start	1988	1992	1997
Production stop	1998	1997	In production
Notes	Self contained hydraulic system to power single blower for air assisted boom. Electricly controlled hydraulic lift, fold, slant, tilt and fold of outer sections only. Trapeze suspension. TRIPLET nozzle holders standard.	Self contained hydraulic system to power single blower for air assisted boom. Electricly controlled hydraulic lift, fold, slant, tilt and fold of outer sections only. Trapeze suspension. TRIPLET standard. Cables help support wings.	Self contained hydraulic system to power two blowers for air assisted boom. Hydraulic lift and fold. Pendulum suspension. TRIPLET nozzle holders standard.

Trailed

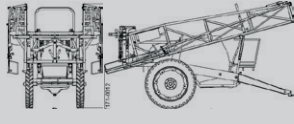
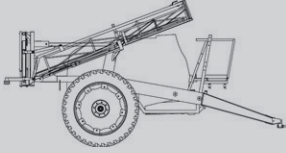
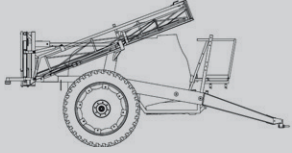
Name COMMANDER			
			
Boom size (m)	18, 20 21, 24, 27, 28	15, 16, 18	15, 16, 18, 20, 21, 24
Boom name	HAZ (TWIN FORCE)	LPY	LPZ
Name origin	Hydraulic Air-assisted Z version	Light Pendulum Y version	Light Pendulum Z version
Production start	1997	1998	1998
Production stop	In production	2005	2005
Notes	Self contained hydraulic system to power two blowers for air assisted boom. Electricly controlled hydraulic boom lift, fold, slant, tilt and fold of outer sections only. Pendulum suspension.TRIPLET nozzle holders standard.	Hydraulic boom lift and fold. Pendulum suspension.TRIPLET nozzle holders standard.	Electricly controlled hydraulic boom lift, fold, slant, tilt and fold of outer sections only. Pendulum suspension. TRIPLET nozzle holders standard.



Trailed

Name COMMANDER plus			
Name origin	Updated version of COMMANDER with drawbar steering as an option.		
Production start	2000		
Production stop	2005		
Tank size (litre)	2200, 2800, 3200, 4200		
Notes	Drawbar hinged to tank frame.		
Boom size (m)	15, 16, 18	15, 16, 18, 20, 21, 24	15, 16, 18, 20, 21, 24
Boom name	LPY	LPZ	LPV
Name origin	Light Pendulum Y version	Light Pendulum Z version	Light Pendulum V version
Production start	1998	1998	1998
Production stop	2005	2005	2005
Notes	Hydraulic boom lift and fold. Pendulum suspension. TRIPLET nozzle holders standard.	Electricly controlled hydraulic boom lift, fold, slant, tilt and fold of outer sections only. Pendulum suspension. TRIPLET nozzle holders standard.	Electricly controlled hydraulic boom lift, fold, slant and fold of outer sections only. Pendulum suspension. TRIPLET nozzle holders standard.
Boom size (m)	18, 20, 21, 24, 27, 28	18, 20, 21, 24, 27, 28	18, 20, 21, 24, 27, 28
Boom name	OLH	OLS	OLV
Name origin	Olympic HARDI	Olympic S version	Olympic V version
Production start	1994	1994	1994
Production stop	2001	2001	2001
Notes	Electricly controlled hydraulic boom lift, fold, slant, tilt and fold. Pendulum suspension. TRIPLET nozzle holders standard.	Hydraulic boom lift, fold, tilt, slant and fold. Hydraulics are indirect (switch and lever). Pendulum suspension. TRIPLET nozzle holders standard.	Electricly controlled hydraulic boom lift, fold, slant and fold. Pendulum suspension. TRIPLET nozzle holders standard.
Boom size (m)	24, 27, 28, 30, 32, 36	24, 27, 28, 30	18, 20, 21
Boom name	GVA	GLA	SPB
Name origin	Geometry Variable Aluminium	Geometry L Aluminium	Spring suspended B version
Production start	2000	2000	1996
Production stop	2004	2004	In production
Notes	Aluminium boom with electricly controlled hydraulic boom lift, fold, slant, tilt and fold. Pendulum suspension. QUADRILET nozzle holders standard.	Aluminium boom with electricly controlled hydraulic boom lift, fold, slant and fold. Pendulum suspension. QUADRILET nozzle holders standard.	Trapeze suspension arms supported by two coil springs. Hydraulic boom lift and fold.

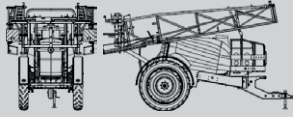
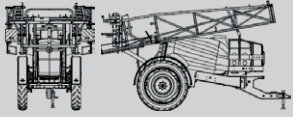
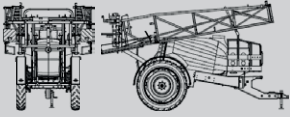
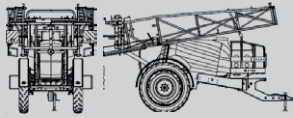
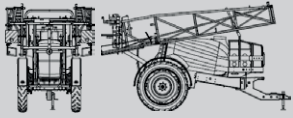
Trailed

Name COMMANDER plus			
			
Boom size (m)	24, 27, 28, 30	18, 20, 21, 24, 27, 28	18, 20, 21, 24, 27, 28
Boom name	SPC	HAY (TWIN FORCE)	HAZ (TWIN FORCE)
Name origin	Spring suspended C version	Hydraulic Air-assisted Y version	Hydraulic Air-assisted Z version
Production start	2002	1997	1997
Production stop	In production	In production	In production
Notes	Trapeze suspension arms supported by coil springs. Hydraulic boom lift. Manual and hydraulic fold version.	Self contained hydraulic system to power two blowers for air assisted boom. Hydraulic lift and fold. Pendulum suspension.	Self contained hydraulic system to power two blowers for air assisted boom. Electricly controlled hydraulic boom lift, fold, slant, tilt and fold of outer sections only. Pendulum suspension.
			
Boom size (m)	24, 27, 28, 30 32, 33, 36	24, 27, 28, 30 32, 33, 36	
Boom name	HPZ (FORCE)	FTZ (FORCE)	
Name origin	Hydraulic Pendulum Z version	FORCE trapeze Z version	
Production start	2001	2001	
Production stop	In production	In production	
Notes	Electricly controlled hydraulic boom lift, fold, slant, tilt and fold. Pendulum suspension.	Electricly controlled hydraulic boom lift, fold, slant, tilt and fold. Trapeze suspension.	

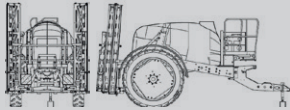
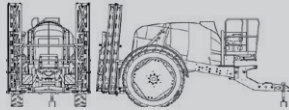
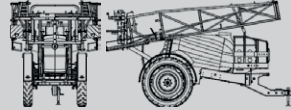
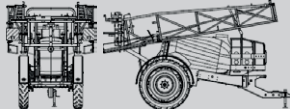
Trailed

Name COMMANDER classic			
Name origin	Economy version of COMMANDER plus.		
Production start	2003		
Production stop	2007		
Tank size (litre)	2200, 2800, 3200, 4200		
Notes	Drawbar hinged to tank frame.		
			
Boom size (m)	12, 15, 16, 18	12, 15, 16, 18	18, 20, 21
Boom name	VHY (PRO)	VHZ (PRO)	SPB
Name origin	Vertical hydraulic Y version	Vertical hydraulic Z version	Spring suspended B version
Production start	2002	2002	1996
Production stop	In production	In production	In production
Notes	Hydraulic lift and fold. Boom folds to vertical position.	Electric over hydraulic lift and fold. Boom folds to vertical position.	Trapeze suspension arms supported by two coil springs. Hydraulic boom lift and fold.
			
Boom size (m)	24, 27, 28, 30	15, 16, 18	15, 16, 18, 20, 21, 24
Boom name	SPC	LPY	LPZ
Name origin	Spring suspended C version	Light Pendulum Y version	Light Pendulum Z version
Production start	2002	1998	1998
Production stop	In production	2005	2005
Notes	Trapeze suspension arms supported by coil springs. Hydraulic boom lift. Manual and hydraulic fold version.	Hydraulic boom lift and fold. Pendulum suspension.	Electrically controlled hydraulic boom lift, fold, slant, tilt and fold of outer sections only. Pendulum suspension.

Trailed

Name COMMANDER 2005			
Name origin	Global COMMANDER		
Production start	2005 (For 6600, start in 2006)		
Production stop	2011		
Tank size (litre)	3200, 4400, 6600		
Notes	RinseTank placed over axle. Introduction of SafeTrack.		
Boom size (m)	18, 20, 21, 24, 27, 28	18, 20, 21, 24, 27, 28	24, 27, 28, 30 32, 33, 36
Boom name	LPY	LPZ	HPZ (FORCE)
Name origin	Light Pendulum Y version	Light Pendulum Z version	FORCE pendulum Z version
Production start	1998	1998	2001
Production stop	In production	In production	In production
Notes	Hydraulic boom lift and fold. Pendulum suspension.	Electric over hydraulic lift and fold. Pendulum suspension.	Electricly controlled hydraulic boom lift, fold, slant, tilt and fold. Pendulum suspension.
Boom size (m)	18, 20, 21, 24, 27, 28, 30, 32, 33, 36	18, 20, 21, 24, 27, 28, 30, 32, 33, 36	
Boom name	HAY (TWIN FORCE)	HAZ (TWIN FORCE)	
Name origin	Hydraulic Air-assisted Y version	Hydraulic Air-assisted Z version	
Production start	1997	1997	
Production stop	In production	In production	
Notes	Self contained hydraulic system to power two blowers for air assisted boom. Hydraulic boom lift and fold. Pendulum suspension.	Self contained hydraulic system to power two blowers for air assisted boom. Electricly controlled hydraulic boom lift, fold, slant, tilt and fold of outer sections only. Pendulum suspension.	

Demount

The following identification tables are based on the models previously produced at the main plant in Denmark. Some model names are still in the current product range but may have different specifications.

There will be variations on naming and production start stop dates of models sold in North America and Australia.

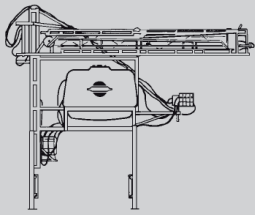
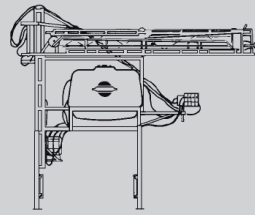
Name		PZ	
Name origin	Pick up Z version		
Production start	1989		
Production stop	1995		
Tank size (litre)	2200		
Notes	Tank has channelled centre to permit view of boom centre.		
			
Boom size (m)	12, 15, 16, 18, 20, 21, 24	20, 21, 24, 28	
Boom name	LHZ	MHZ	
Name origin	Light Hydraulic Z version	Medium Hydraulic Z version	
Production start	1982	1989	
Production stop	1998	2000	
Notes	Electricly controlled hydraulic boom lift, fold, slant, tilt and fold of outer sections only. Trapeze suspension. TRIPLET nozzle holders standard.	Electricly controlled hydraulic boom lift, fold, slant, tilt and fold of outer sections only. Trapeze suspension. TRIPLET nozzle holders standard.	

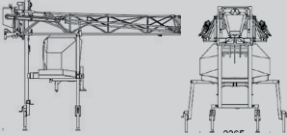
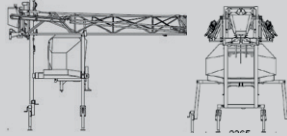
Name		DM	
Name origin	Demount		
Production start	1993		
Production stop	2000		
Tank size (litre)	2000		
Notes	Tank is made of fibreglass.		
			
Boom size (m)	12, 15, 16, 18, 20, 21, 24	18, 20, 21, 24, 27, 28	
Boom name	LHZ	OLH	
Name origin	Light Hydraulic Z version	Olympic HARDI	
Production start	1982	1994	
Production stop	1998	2001	
Notes	Electricly controlled hydraulic boom lift, fold, slant, tilt and fold of outer sections only. Trapeze suspension. TRIPLET nozzle holders standard.	Electricly controlled hydraulic boom lift, fold, slant, tilt and fold. Pendulum suspension. TRIPLET nozzle holders standard.	

Demount

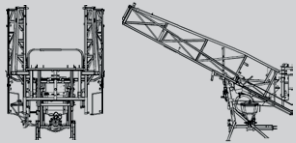
Name		MARRO	
Name origin			
Production start	1988		
Production stop	2002		
Tank size (litre)	1300		
Notes	Tank fitted to front of tractor		
			
Boom size (m)	18, 20, 21, 24, 27, 28		
Boom name	HAZ (TWIN FORCE)		
Name origin	Hydraulic Air-assisted Z version		
Production start	1997		
Production stop	In production		
Notes	Self contained hydraulic system to power two blowers for air assisted boom. Electricly controlled hydraulic boom lift, fold, slant, tilt and fold of outer sections only. Pendulum suspension. TRIPLET nozzle holders standard.		





CHAPTER 1

Abbreviations



A

AF	AutoFill liquid filling equipment
AH	AutoHeight boom management
AMP	Brand of electrical connectors
AR	ARROW mistblower
AS	AutoSlant boom management
ASC	AutoSectionControl nozzle management system
AT	AutoTerrain boom management
ATV	All Terrain Vehicle sprayer
AW	AutoWash sprayer cleaning management

B

BDU	Band spraying equipment
BK	Control unit (Danish: Betjening, Kugle)
BL	Lift-mounted field sprayer (Danish: Beholder, Liggende)
BP	Backpack hand-operated sprayer
BPM	Backpack motorised sprayer

C

C	Compression hand-operated sprayer
CAN	Controller Area Network
CM	COMMANDER field sprayer
CM+	COMMANDER plus field sprayer
CR	CONDOR orchard sprayer

D

DAH	Direct Activated Hydraulics
DDY, DDZ	DELTA FORCE boom
DF4	DynamicFluid4 liquid regulation system
DH	Direct Hydraulics
DM	Demount field sprayer

E

EC	Electric Control unit
EFC	Electric Fast Control unit
EVC	Electric Valve Control unit

F

FF	FLAT FAN nozzle
-----------	-----------------

G

GPS	Global Positions Systems
------------	--------------------------

H

HAB, HAC	TWIN System boom, variant B & C
HAL	TWIN STREAM boom
HAT	HARDI Auto Track
HAY, HAZ	TWIN FORCE boom, variant Y & Z
HB	Heavy Boom
HC	HARDI Controller
HFA	Horizontal Fold boom, variant A
HFM	Horizontal Fold boom, manual fold
HN	HARDI NOVA controller
HP	HARDI PILOT controller
HPZ, FTZ	FORCE boom, variant Pendulum & Trapeze
HT	Pumps with HT: High Pressure (Danish: Høj Tryk)
HT	HARDI TRONIC controller

I

I	INJET nozzle
----------	--------------

J

JP	JUPITER mistblower
-----------	--------------------

K

K	Knapsack hand-operated sprayer
KS	Wheelbarrow sprayer (Danish: Kæresprøjte)



L

LB, LE Lift-mounted mistblower, variant B & E

LD LOWDRIFT nozzle

LHY, LHZ Light Hydraulic boom, variant Y & Z

LPY, LPZ DELTA boom, variant Y & Z

LU LUNIS mistblower

LX, LY, LZ Lift-mounted field sprayer, variant X, Y & Z

M

MA MASTER field sprayer

MB Medium Boom

MD MINIDRIFT nozzle

MDD MINIDRIFT DUO nozzle

ME MEGA field sprayer

MHY, MHZ Medium Hydraulic boom, variant Y & Z

MR MERCURY mistblower

MRY Motorised backpack sprayer

N

NAV NAVIGATOR field sprayer

NK NK field sprayer (Danish: Ny Kuffert)

NP NEPTUN mistblower

O

OLH Olympic HARDI boom

P

P Pressure hand-operated sprayer

PF PrimeFlow boom circulation system

PRO-VP PRO boom, Vertical Pommier

PU Pick Up sprayer

PY, PZ Demount sprayer

Q

Q QUINTASTREAM nozzle

R

RAN RANGER field sprayer

S

SB Small Boom

SB-HY Small Boom with Hydraulic fold

SPA Spring boom, variant A

SPB, SPC EAGLE boom, variant B & C

SPV Special Vine mistblower unit

T

T22 Boom tubes and fittings with 22mm diameter

T25 Boom tubes and fittings with 25mm diameter

TB, TC, TS Trailed mistblower, variant B, C & S

TDZ TERRA FORCE boom

TE, TEV Trailed mistblower, variant Vine

TP Trailed Pneumatic mistblower

TR Trolley sprayer

TX, TY, TZ Trailed field sprayer, variant X, Y & Z

V

VHY, VHZ PRO bom; Vertical Hydraulic, variant Y & Z

VP Vertical Pommier

Z

ZA ZATURN mistblower

ZE ZENIT mistblower



Your Crop Care Partner

HARDI INTERNATIONAL A/S

Herthadalvej 10 · 4840 Nørre Alslev · Denmark · Tel: +45 54 46 48 00
Email: info@hardi.com · www.hardi.com