

SERVICE MANUAL

Field-IQ ISOBUS Sprayer

SPRAYER-CONTROLLER MIDI 3.0

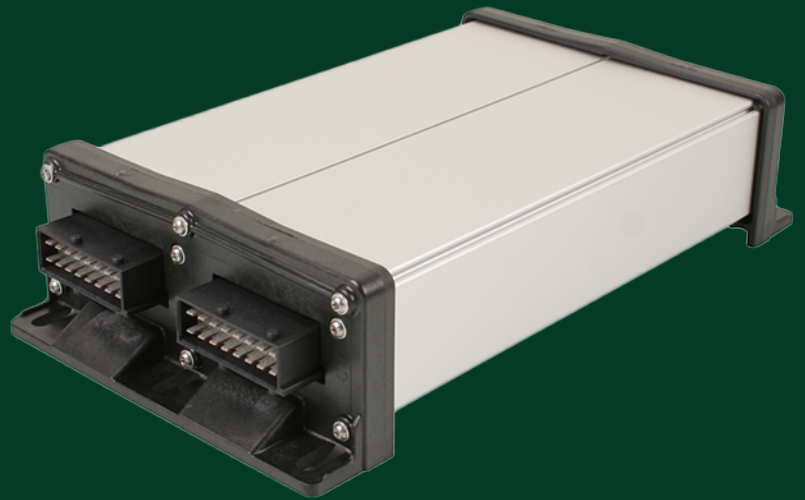

PTx
Trimble

Version V7.20240625

June 2024

Legal Notices

Agriculture Business Area

PTx Trimble
10368 Westmoor Drive
Westminster, CO 80021-2712
USA

ptxtrimble.com

Copyright and Trademarks

© 2024, PTx Trimble LLC. All rights reserved.

PTx and associated Logo are trademarks of AGCO Corporation. Trimble and the Globe & Triangle logo are trademarks of Trimble Inc, registered in the United States and in other countries.

All other trademarks are the property of their respective owners.

Warranty Exclusions and Disclaimer

These warranties shall be applied only in the event and to the extent that (i) the Products and Software are properly and correctly installed, configured, interfaced, maintained, stored, and operated in accordance with Trimble's relevant operator's manual and specifications, and; (ii) the Products and Software are not modified or misused. The preceding warranties shall not apply to, and Trimble shall not be responsible for defects or performance problems resulting from (i) the combination or utilization of the Product or Software with hardware or software products, information, data, systems, interfaces or devices not made, supplied or specified by Trimble; (ii) the operation of the Product or Software under any specification other than, or in addition to, Trimble's standard specifications for its products; (iii) the unauthorized, installation, modification, or use of the Product or Software; (iv) damage caused by accident, lightning or other electrical discharge, fresh or salt water immersion or spray; or (v) normal wear and tear on consumable parts (e.g., batteries). Trimble does not warrant or guarantee the results obtained through the use of the Product.

THE WARRANTIES ABOVE STATE TRIMBLE'S ENTIRE LIABILITY, AND YOUR EXCLUSIVE REMEDIES, RELATING TO PERFORMANCE OF THE PRODUCTS AND SOFTWARE. EXCEPT AS OTHERWISE EXPRESSLY PROVIDED HEREIN, THE PRODUCTS, SOFTWARE, AND ACCOMPANYING DOCUMENTATION AND MATERIALS ARE PROVIDED "AS-IS" AND WITHOUT EXPRESS OR IMPLIED WARRANTY OF ANY KIND BY EITHER TRIMBLE INC. OR ANYONE WHO HAS BEEN INVOLVED IN ITS CREATION, PRODUCTION, INSTALLATION, OR DISTRIBUTION INCLUDING, BUT NOT LIMITED TO, THE IMPLIED WARRANTIES OF MERCHANTABILITY AND FITNESS FOR A PARTICULAR PURPOSE, TITLE, AND NONINFRINGEMENT. THE STATED EXPRESS WARRANTIES ARE IN LIEU OF ALL OBLIGATIONS OR LIABILITIES ON THE PART OF TRIMBLE ARISING OUT OF, OR IN CONNECTION WITH, ANY PRODUCTS OR SOFTWARE. SOME STATES AND JURISDICTIONS DO NOT ALLOW LIMITATIONS ON DURATION OR THE EXCLUSION OF AN IMPLIED WARRANTY, SO THE ABOVE LIMITATION MAY NOT APPLY TO YOU.

TRIMBLE INC. IS NOT RESPONSIBLE FOR THE OPERATION OR FAILURE OF OPERATION OF GPS SATELLITES OR THE AVAILABILITY OF GPS SATELLITE SIGNALS.

Limitation of Liability

TRIMBLE'S ENTIRE LIABILITY UNDER ANY PROVISION HEREIN SHALL BE LIMITED TO THE AMOUNT PAID BY YOU FOR THE PRODUCT OR SOFTWARE LICENSE. TO THE MAXIMUM EXTENT PERMITTED BY APPLICABLE LAW, IN NO EVENT SHALL TRIMBLE OR ITS SUPPLIERS BE LIABLE FOR ANY INDIRECT, SPECIAL, INCIDENTAL OR CONSEQUENTIAL DAMAGES WHATSOEVER UNDER ANY CIRCUMSTANCE OR LEGAL THEORY RELATING IN ANY WAY TO THE PRODUCTS, SOFTWARE AND ACCOMPANYING DOCUMENTATION AND MATERIALS, (INCLUDING, WITHOUT LIMITATION, DAMAGES FOR LOSS OF BUSINESS PROFITS, BUSINESS INTERRUPTION, LOSS OF BUSINESS INFORMATION, OR ANY OTHER PECUNIARY LOSS), REGARDLESS WHETHER TRIMBLE HAS BEEN ADVISED OF THE POSSIBILITY OF ANY SUCH LOSS AND REGARDLESS OF THE COURSE OF DEALING WHICH DEVELOPS OR HAS DEVELOPED BETWEEN YOU AND TRIMBLE. BECAUSE SOME STATES AND JURISDICTIONS DO NOT ALLOW THE EXCLUSION OR LIMITATION OF LIABILITY FOR CONSEQUENTIAL OR INCIDENTAL DAMAGES, THE ABOVE LIMITATION MAY NOT APPLY TO YOU.

NOTE: THE ABOVE LIMITED WARRANTY PROVISIONS MAY NOT APPLY TO PRODUCTS OR SOFTWARE PURCHASED IN THE EUROPEAN UNION. PLEASE CONTACT YOUR TRIMBLE DEALER FOR APPLICABLE WARRANTY INFORMATION.

Contents

For Your Safety	1
Basic Safety Instructions	2
Operation	2
Servicing	2
Intended Use	2
Layout and Meaning of Warnings	3
Layout and Meaning of Alert Messages	3
User Requirements	4
Safety Sign for the Field Sprayer	4
Safety Stickers on the Product	5
Disposal	5
EU Declaration of Conformity	5
About These Instructions	6
Scope of the Instructions	7
Diagrams in This Manual	7
Directional Information in These Instructions	7
About the ECU	8
ECU Functions	9
System Overview	9
Main System - MIDI	10
Extension: DISTANCE-Control II	11
Extension: EDS	11
Software Extensions	12
Rating Plate	12
Mounting and Installation	13
Installing the ECU	14
Connecting the AMP connectors	14
Separating the AMP connectors	15
Connecting the ECU to the ISOBUS	16
Installing the Junction Box	16
Connecting the Sensors and Actuators to the Junction Box	17
Inserting the Cable Core into a Terminal	17
Connecting the Junction Box to the ECU	18
Basic Control Principles	19
Switching on the ECU	20

Layout of the Work Screen	20
Spray data area	21
Boom Display Area	22
Control Units	29
Operating the ECU on the Field	30
Tank Filling	31
Filling the Tank Manually without Additional Systems	31
Filling the Tank with Filling Pump	31
Filling the Tank with Fill Stop	32
Filling the Tank with TANK-Control I	34
Filling the Tank with Integrated TANK-Control III	37
Controlling the Boom	40
Lifting and Lowering the Boom	40
Folding and Unfolding the Boom	41
Starting the Application	47
Immediate Application	48
Regulating the Application Rate	48
Changing the Application Rate in Manual Mode	49
Using Automatic Mode	49
Setting Target Rate	51
Stopping Application	52
Operating Sections	52
Documenting Work Results	53
Using Pressure Registration	54
Setting the Rotational Speed	54
Operating the PTx Joystick	55
Preview Mode for the PTx Joystick	55
Viewing the Assignment of the PTx Joystick	56
Using Foam Markers	57
Operating Additional Functions	57
Regulating Drop Size with AIRTEC	59
Airtec Icons	59
Switching the Air Compressor On and Off	60
AIRTEC in Automatic Mode	61
AIRTEC in Manual Mode	61
Using ISB Short-Cut Button	62
Trailed Implement with Dual Axles	62
Stirring Control	62
TC-GEO Management	64

Configuring the ECU	66
Entering Sprayer Parameters	67
Configuring the Control Units	69
Configure ISO Settings	70
Viewing the AEF certification	70
Configuring the Communication with the Terminal (Condensed Work State)	70
Rearranging the Function Icons	71
Selecting the Terminal	71
Color Customization	72
Calibrating the Flow Meter	73
Calibrating the Flow Meter with the Tank Method	73
Calibrating the Flow Meter with the Nozzle Method	75
Manually Entering the Number of Impulses per Liter for the Flow Meter	77
Combining the Flow Meter with the Pressure Sensor	78
Calibrating an Analog Pressure Sensor	78
Selecting and Configuring the Speed Sensor	79
Selecting the Speed Source	79
Calibrating the Speed Sensor with the 100m Method	80
Configuring the Reverse Driving Sensor	81
“Simulated Speed” Function	82
Configuring Sections	83
Entering the Number of Nozzles per Section	83
Switching Sections Off Permanently	83
Permanently Switching Off a Section using a Sensor	84
System Delay When Switching the Sections	84
Changing the Display of Areas on the Terminal	85
Configuring the Nozzles - for sprayers with pressure sensor regulation	85
Nozzle Assistant	86
Calibrate the Nozzles	88
Extremity Nozzles	89
Configuring the Extremity Nozzles	90
Operating the Extremity Nozzles	91
Rotational Speed Configuration	92
Band Spraying Configuration	93
Spot Spraying Configuration	94
Configuring AIRTEC	94
Configuring the Integrated TANK-Control III	95
Performing the 100 Litre Calibration	95
Performing the Basic Initialization	96
Carrying Out Calibration	96
Planning Calibration	96

Changing the Number of Sensors	100
Configuring the Units	100
Entering the Password	101
Entering the Sprayer Geometry	101
Sprayer Geometry Parameters	101
Configuring the Raven Direct Injection	102
Status of the Raven Direct Injection	102
Calibrating the Sensors for Reproducing the Boom Slope	103
Field Sprayer with Two Circulations and ECUs	104
Identifying the ECU	105
Geometry on a Field Sprayer with Two ECUs	106
Activating Licenses	107
Assigning the Joystick Buttons	108
Extension: TRAIL-Control	109
For Your Safety	110
About TRAIL-Control	110
System Functions	110
System Overview	111
Mounting and Installation	112
Mounting the Gyroscope	112
Using the Gyroscope	113
Checking the Installation Position of Sensors	114
Hydraulic System	114
Basic Control Principles	125
Switching TRAIL-Control On and Off	125
Layout of the Work Screen	126
Operating TRAIL-Control on the Field	129
Steering the Trailed Implement	129
Preparing TRAIL-Control for Road Driving	133
Driving in Reverse	133
Locking TRAIL-Control	134
Configuring TRAIL-Control	134
Adjusting the Configuration to the Tractor	134
Calibrating TRAIL-Control	135
Configuring the Automatic Centering	140
Configuring Automatism When Driving in Reverse	142
Extension: DISTANCE-Control	144
For Your Safety	145
Safety Mechanisms	145
Safety Distances	146

Intended Use	146
About DISTANCE-Control	146
Mode of Operation	146
System Overview	147
Mounting and Installation	148
Boom Requirements	148
Ultrasonic Sensors	151
Angle Sensors	154
Slope Sensors	158
Basic Control Principles	158
Initial Start-up	158
Activating DISTANCE-Control and Switching to Manual Mode	158
Operating DISTANCE-Control While Working	159
Configuring DISTANCE-Control	160
Activating DISTANCE-Control	160
Calibrating DISTANCE-Control	160
Configuring Working Height	164
Configuring Boom Raising Height	165
Selecting the Work Mode	166
Configuring the Chassis/Boom Factor	166
Configuring the Regulation Speed	166
Configuring the (Minimum) Safety Height	167
Troubleshooting DISTANCE-Control	168
Frequent Issues	168
Alarm Messages	169
System Troubleshooting	170
Finding the Source of a Short Circuit	171
Extension: DISTANCE-Control II	172
For Your Safety	173
Safety Mechanisms	173
Safety Distances	173
Intended Use	174
About DISTANCE-Control II	174
System Functions	174
System Overview	175
Mounting and Installation	175
Boom Requirements	175
Ultrasonic Sensors	178
Angle Sensors	183
Basic Control Principles	187
Initial Start-up	187

Starting DISTANCE-Control II	187
Screen Layout on the "System Data" Screen	187
Operating DISTANCE-Control II on the Field	188
Activating DISTANCE-Control and Switching to Manual Mode	188
Setting Working Mode and Boom rais. Mode	189
Setting the Working Height and Boom Raising Height	190
Configuring DISTANCE-Control II	191
"System Data" Screen	191
Calibrating DISTANCE-Control	191
Using the Password-Protected Area for Configuration	197
Opening the Password-Protected Area	198
Selecting the Configuration Method	198
Inputting the Position of the Ultrasonic Sensors	200
Adjusting Reaction Speed for Manual Operation	201
Adjusting the Control Speed in Automatic Mode	202
Configuring Tolerances	205
Setting the Maximum Speed	206
Special Functions	206
Troubleshooting DISTANCE-Control	208
Frequent Issues	208
Finding the Source of a Short Circuit	208
Extension: EDS	210
About EDS	211
System Functions	211
System Overview	211
Intended Uses	213
Mounting and Installation	215
Install the EDS Communication Module	215
Mounting EDS Modules	215
Connecting the Nozzle Holders to the EDS Modules	216
Connecting the Cable	218
Operating Individual Nozzle Switching on the Field	218
Configuring the Single Nozzle Switching	219
Configuring the EDS Communication Module on the Terminal	219
Configuring SECTION-Control for EDS	223
Vario and Select Mode - Configuring Multiple Nozzle Holders	223
Before You Buy Nozzles - Check the Possible Application Rates	224
Vario Mode - Automatic Nozzle Selection	226
Select Mode - Manual Nozzle Selection	228
Configuring the Nozzles on the Multiple Nozzle Holder	229
Setting the Drop Size	230

Deactivating Nozzles	231
Configuring CURVE-Control	232
Troubleshooting EDS	233
Search for Faulty EDS Modules	233
Using the Diagnostic Function of the EDS Modules	234
After a Module Change	234
Troubleshooting	235
Checking the Software Version	236
Diagnostic	236
Checking the Measured Values for the Connection Pin	236
Importing and Exporting Files	238
Importing a Configuration File from the FILE-Server	238
Exporting a Configuration File to the FILE-Server	240
Loading the Configuration from the Internal Memory of the ECU	240
Managing the Error Memory	241
Displaying the ECU Information	243
Configuring the Factory Parameters	243
Technical Specifications	244
ECU-MIDI 3.0 Technical Specifications	245
42-Pin General Information	245
42-Pin Connector Assignment	247
16-Pin IN Connector Pin Assignment	249
16-Pin OUT Connector Pin Assignment	250
Junction Box	251
DISTANCE-Control	252
Ultrasonic Sensors	252
Angle Sensors	252
Slope Sensor	253
DISTANCE-Control II	254
Ultrasonic Sensors	254
Angle Sensors	254
EDS Module	255
Technical Specifications of the EDS Modules	255
Cable Harness Pin Assignment	255
Available Languages	257
Item Overview	258
SPRAYER-Controller MIDI 3.0	259
ISOBUS ECU with Expansion ECU for Sprayers	259
Accessories	259

Flow Meter	260
Pressure Sensor	260
TRAIL-Control	261
Optional for ECU MIDI 3.0	261
Optional	261
Connector Cable for Sensors and Gyroscope	261
DISTANCE-Control	262
ISOBUS DISTANCE-Control with 2 Ultrasonic Sensors, with 1 Slope Sensor	262
ISOBUS DISTANCE-Control with 2 Ultrasonic Sensors, with 2 Slope Sensors	262
DISTANCE-Control II	263
EDS Module	264
ECU EDS	264
EDS Equipment	264
Optional for Gyroscope	264
Connector Cable for Sensors and Gyroscope	264
EDS Electric ECU	265

For Your Safety

- Basic Safety Instructions
- Intended Use
- Layout and Meaning of Warnings
- User Requirements
- Safety Sign for the Field Sprayer
- Safety Stickers on the Product
- Disposal
- EU Declaration of Conformity

Basic Safety Instructions

Operation

CAUTION – Be sure to always comply with the following instructions during operation:

- Before you leave the vehicle cab, ensure that all automatic mechanisms are deactivated or manual mode is activated.
- In particular, deactivate the following systems if they are installed:
 - TRAIL-Control
 - DISTANCE-Control
- Keep children away from the implement and the ECU.
- Carefully read and follow all safety instructions in this manual and in the machine's manual.
- Observe all applicable regulations on accident prevention.
- Follow all recognised safety, industrial and medical rules as well as all road traffic laws.
- Use only clear water when you are testing the sprayer. Do not use a poisonous spray during the tests or when calibrating the systems.

Servicing

CAUTION – Keep the system in a functional condition. To do so, follow these instructions:

- Do not make any unauthorized modifications to the product. Unauthorized modifications or use may impair safety and reduce the service life or operability of the unit. Modifications are considered unauthorized if they are not described in the product documentation.
- Never remove any safety mechanisms or stickers from the product.
- Before charging the tractor battery, always disconnect the tractor from the product.
- Before performing any welding on the tractor or the implement, always disconnect the power supply to the ECU.
- The ECU and the cabling must not be repaired. Unauthorised attempts at repairs can fail and cause hazardous malfunctions.
- Use only original accessories as spare parts.

Intended Use

The ECU is used to control machines in agriculture. The manufacturer shall not be held responsible for any installation or use that goes beyond this.

Intended use also includes compliance with the conditions for operation and repairs prescribed by the manufacturer.

The manufacturer cannot be held liable for any personal injury or property damage resulting from non-compliance. All risk arising from improper use lies with the user.

All applicable accident prevention regulations and all other generally recognized safety, industrial, and medical standards as well as all road traffic laws must be observed. Any unauthorized modifications made to the equipment will void the manufacturer's warranty.

Layout and Meaning of Warnings

All safety instructions found in these Operating Instructions are composed in accordance with the following pattern:

WARNING –

This signal word identifies medium-risk hazards, which could potentially cause death or serious physical injury, if not avoided.

CAUTION –

This signal word identifies hazards that could potentially cause minor or moderate physical injury or damage to property, if not avoided.

DANGER!

THIS SIGNAL WORD IDENTIFIES HAZARDS THAT COULD POTENTIALLY CAUSE DAMAGE TO PROPERTY, IF NOT AVOIDED.

There are some actions that need to be performed in several steps. If there is a risk involved in carrying out any of these steps, a safety warning appears in the instructions themselves.

Safety instructions always directly precede the step involving risk and can be identified by their bold font type and a signal word.

Example

1. **NOTICE! This is a notice. It warns that there is a risk involved in the next step.**
2. Step involving risk.

Layout and Meaning of Alert Messages

An alarm message may appear during operation and have the following purpose:

- **Warning** - These messages warn the operator if the current status of the field sprayer could lead to a dangerous situation.
- **Information** - These messages inform the operator that the current status of the field sprayer or configuration is not correct and could lead to faults in operation.

On the following diagram, you can see how the alarm messages are structured:

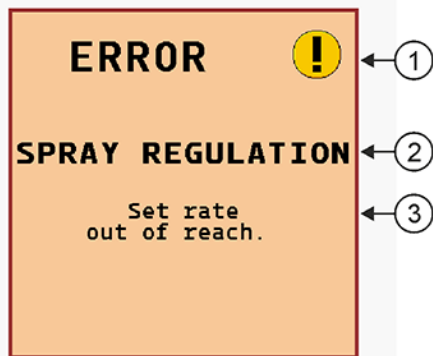

Item	Description
1	Type of alarm
2	Name of the component that caused the alarm.
3	Problem description and solution Information on the exact cause of an alarm message or how to rectify a fault can be found in the section "Alarm messages"

User Requirements

- Learn to operate the product in accordance with the instructions. Nobody must operate the product before reading these instructions.
- Please read and carefully observe all safety instructions and warnings contained in these Operating Instructions and in the manuals of any connected vehicles and farm equipment.
- If there is anything within these instructions that you do not understand, please do not hesitate to contact your dealer.

Safety Sign for the Field Sprayer

If the field sprayer is fitted with drawbar steering or with axle steering, everyone approaching the field sprayer must be warned of possible dangers. For that reason you receive a safety sign.

Post the safety sign in the appropriate place. When attaching safety signs, observe the following:

- Safety signs must be attached at a visible location so that they can be seen by everyone approaching the danger zone.
- If the danger area can be approached from several sides of the implement, attach the warning signs on all implement sides.
- Regularly check the safety signs for completeness and legibility.
- Replace damaged or unreadable signs with new ones.

Safety Sign	Where to attach	Meaning
	Near the bend area between tractor and trailed implement.	Do not stay in the bend area during operation.

Safety Stickers on the Product

Sticker	Meaning
	Do not clean with a high-pressure cleaner.

Disposal



When it has reached the end of its service life, please dispose of this product as electronic scrap in accordance with all applicable waste management laws.

EU Declaration of Conformity

Herewith we declare that the design and construction of this product and its identical variants, as well as the form brought onto the market by us, is in accordance with the relevant safety and health requirements of the following directives.

EU directives:	2014/30/EU EMV Directive 2011/65/EU RoHS Directive
Harmonised standards applied:	EN ISO 14982:2009 EN IEC 63000:2018

About These Instructions

- Scope of the Instructions
- Diagrams in This Manual
- Directional Information in These Instructions

Scope of the Instructions

These instructions describe all of the functions that can be actuated with the ECU. This means that some chapters may not be relevant for the operation of certain implements.

Diagrams in This Manual

The screenshots of the software interface are intended to serve as a reference. They help you in finding your way around the software screens.

The information shown on the screen depends on various factors:

- The implement type.
- The implement configuration.
- The implement status.
- The implement has different colors on the terminal than in the instructions.
 - Different background color.
 - The icons described in the instructions appear in a different position on the screen.
 - Some of the described functions are not available in the system.

Directional Information in These Instructions

All directional information in these instructions, such as “left”, “right”, “forward”, “back”, is relative to the movement direction of the vehicle.

About the ECU

- ECU Functions
- System Overview
- Main System - MIDI
- Extension: DISTANCE-Control II
- Extension: EDS
- Software Extensions
- Rating Plate

ECU Functions

The SPRAYER-Controller MIDI 3.0 ECU is an ISOBUS ECU that can control the operation of field sprayers.

The ISOBUS ECU is the control central of the sprayer. Several sensors are connected to the ECU, which monitor important implement parts. The ECU controls the implement based on these signals and on the operator's specifications. An ISOBUS terminal serves as an interface. All implement-specific data is stored in the ECU and is therefore maintained even when changing the terminal.

System Overview

The main system always consists of a base ECU, onto which other additional components can be installed. The overall system can have various sizes depending on these additional components.

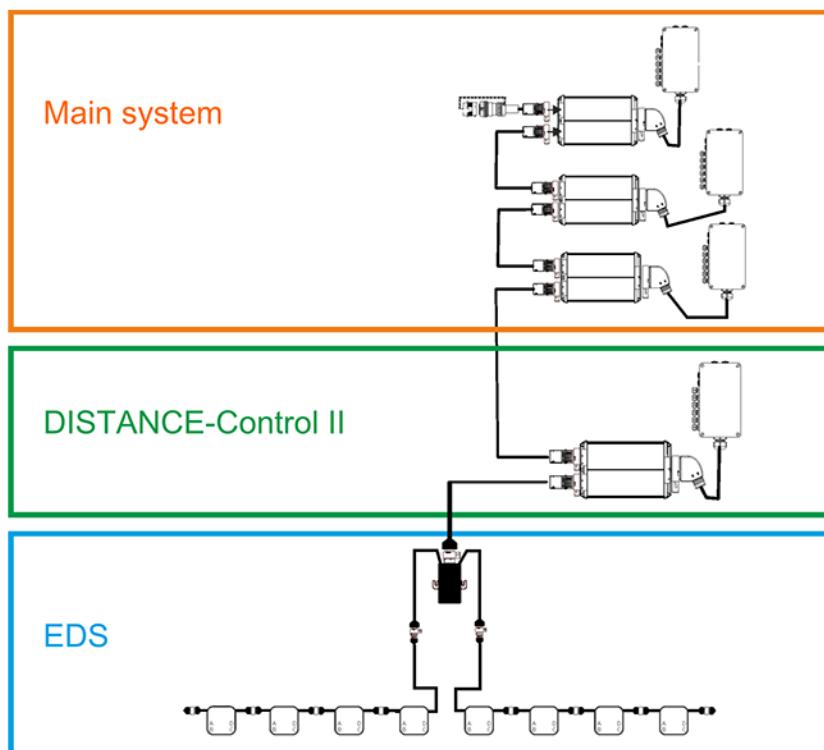

Example: SPRAYER-Controller MIDI 3.0 with DISTANCE-Control II and EDS

Main System - MIDI

The system can be expanded. The basic version consists of one to three ECUs. The first ECU is connected to the ISOBUS power socket on the tractor.]

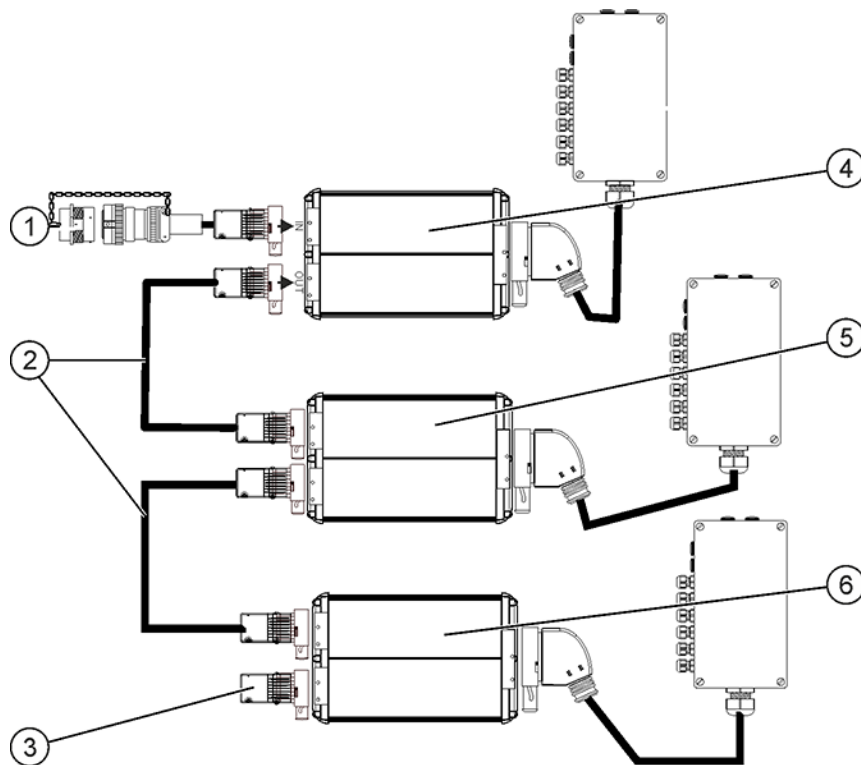

Main system of the MIDI 3.0 version

Item	Description	Item	Description
1	Connector cable for ECU to ISOBUS Connection to ISOBUS power socket	4	Primary ECU-MIDI 3.0
2	Connector cable	5	Secondary ECU-MIDI 3.0
3	Termination plug or connection of extensions	6	Secondary ECU-MIDI 3.0

Extension: DISTANCE-Control II

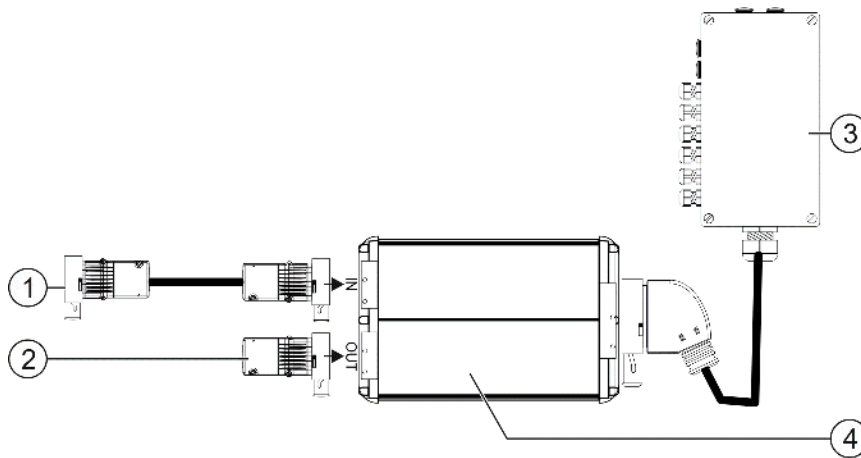

DISTANCE-Control II

Item	Description	Item	Description
1	Connection to the last ECU-MIDI 3.0 ECU.	3	Junction box
2	Termination plug. Otherwise, connection of other extensions.	4	Job computer

Extension: EDS

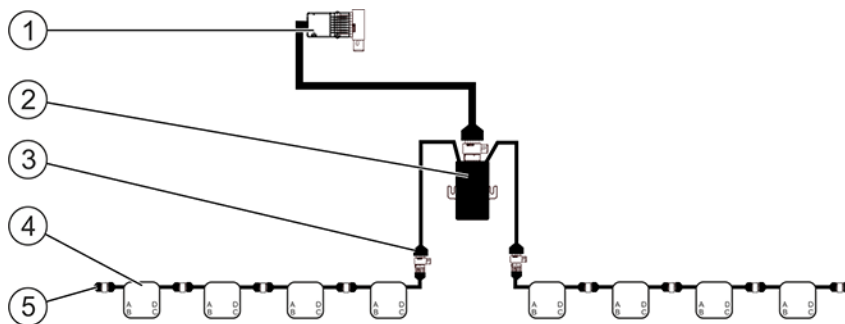

EDS

Item	Description	Item	Description
1	Connection to the main system or to a system add-on	4	EDS modules
2	EDS communication module	5	Termination plug
3	Connection to the EDS bus		

Software Extensions

In addition to the functions that are configured as a standard, there are software extensions that can be additionally activated:

- TRAIL-Control
- DISTANCE-Control
- VARIO-Select

Rating Plate

Abbreviation	Meaning
K.-Nr.:	Customer number If the product was manufactured for an agricultural machinery manufacturer, the agricultural machinery manufacturer's item number will be shown here.
HW:	Hardware version
P/N:	PTx Trimble item number
DC:	Operating voltage The product may only be connected to voltages within this range.
SW:	Software version upon delivery
SN:	Serial number

Mounting and Installation

- Installing the ECU
- Connecting the ECU to the ISOBUS
- Installing the Junction Box

Installing the ECU

CAUTION – Instructions for safe installation

To prevent damage to the system components, consider the following during installation:

- Install the ECU where it is protected from dirt. You therefore avoid unintentional cleaning of the ECU by the implement operator using a high-pressure cleaner.
- In the installed position, the connectors and the pressure compensation membrane must be facing to the side.
- Fasten the ECU with four fixing bolts and a flat washer (lock washers can cause cracks in the plastic on the long term) on a conducting spot on the implement chassis. In case of improper installation, the ESD discharges can cause malfunctions.
- All of the sockets and connectors that are not used must be protected from dust and water using suitable dummy connectors.
- All of the connectors must be tightly sealed. This makes them waterproof.
- The connection cable must be mechanically supported in the area of the installation site (distance < 150 mm) so that an in-phase stimulation takes place.
- Do not use the system if some of its parts are damaged. Damaged parts can cause malfunctions and lead to injuries. Replace damaged components.
- Only use original components.

Connecting the AMP connectors

To connect two AMP connectors:

1. Pull out the red locking device of the AMP socket all the way to the end.



- You will hear a loud clicking sound.
 - The openings for inserting the locking pins of the connector are visible.
2. Insert the connector into the socket. It should be possible to easily insert the locking pins in the openings.



The connector is loosely inserted in the socket.

3. Press in the red locking device.



- You will hear a loud clicking sound.
- A part of the locking device comes through to the other side of the socket.

You have connected and locked the connector with the socket.



Separating the AMP connectors

To separate two AMP connectors:

1. Press in both ends of the red locking device in direction of the connector.



You will hear a loud clicking sound.



The locking device has been released.

2. Pull out the red locking device of the AMP socket all the way to the end.
3. Pull the connector out of the socket.

Connecting the ECU to the ISOBUS

To connect the ECU to the power supply and to the ISOBUS terminal, you have to connect the ISOBUS cable to an ISOBUS power socket on the tractor.

To connect the ECU to the ISOBUS:

1. Take the ISOBUS cable from the ECU.
2. Unscrew the dust protection cap.



3. Insert the ISOBUS connector into the ISOBUS power socket on the tractor.
4. Lock the connector. For basic vehicle harnesses from PTx Trimble, turn the connector clockwise. For other ISOBUS basic vehicle harnesses, the procedure depends on the model.

The connector fits tightly.

5. Screw the dust protection cap of the connector and the socket together.



6. When the work is completed, separate the connection and screw the dust protection cap back on.



Installing the Junction Box

Take note of the following when selecting the installation location:

- Ensure that cables cannot be damaged by the moving implement.
- The cable glands must be facing downwards.

Connecting the Sensors and Actuators to the Junction Box

Every sensor and every actuator that is mentioned in the pin-out diagram must be connected to the connection in the junction box mentioned in the pin-out diagram.

This can be done in two ways:

- The sensor or actuator ends with a short cable and an AMP connector.
In this case, you will receive a fitting sensor connection cable for each sensor. You must insert the sensor connection cable in the junction box and connect it to the fitting terminal.
- The sensor or actuator ends with a long cable without a connector. You have to insert it in the junction box and connect it to the fitting terminal.

The terminal to which you must connect the cable core depends on the respective implement and on the type of sensor or actuator.

Please note that the cable cores for the ultrasonic sensor trigger always need to be connected to Pins 2 and 3.

DANGER! RISK OF SHORT-CIRCUIT

WHEN EXCHANGING THE POLARITY OF CABLE CORES, MACHINE SENSORS CAN BE DAMAGED BY A SHORT-CIRCUIT.

PAY ATTENTION TO THE POLARITY OF THE CABLE CORES AND THE TERMINALS.

Before you begin:

- The junction box is not powered.
 - There is no voltage on the components to be connected.
1. Remove the cable coating so that all cable cores are exposed.
 2. Insert the cable to the end of the coat. There should only be cable cores inside the junction box. The cable coating must end at the junction box casing. This is the only way to ensure that you have enough space in the junction box to be able to guide all of the cable cores to the terminals.
 3. Remove the cable coating of the cable cores ca. 1 cm from the end of the cable core.

CAUTION – Pay attention to the proper polarity of the cable cores and the terminals.

4. Connect the cable cores to the terminals. To do so, use the information on the lid of the junction box, on the relay circuit board and in the pin-out diagram.
5. Close the screw connections of the junction box.
After screwing them shut, the glands should be sealed.
6. Close unused openings in the casing of the junction box with blind caps.

Inserting the Cable Core into a Terminal

Each terminal consists of two openings:

- The upper opening or the orange opening point of the terminal opens the lower opening.
- The bottom opening of the terminal serves to insert and clamp one cable core.

Before you begin:

- You have prepared a small flat screwdriver that fits the upper opening of the terminal. You only need this screwdriver if there are no wire end sleeves on the cable cores.
 - You have cut the cable to the proper length and have exposed the cable cores according to the instructions, or you have a finished cable from PTx Trimble.
 - The tractor engine is switched off.
 - The junction box is not powered.
 - There is no voltage on the components to be connected.
1. Find the proper connectors for the cable cores to be connected.
To do so, use the information on the lid of the junction box, on the relay circuit board and in the pin-out diagram.
 2. Insert the cable core into the opening in the lower part of the terminal. If you are not using wire end sleeves, you first have to use the screwdriver.

The cable core will be held by the terminal.

You have clamped the cable core.

Connecting the Junction Box to the ECU

Connect the AMP connector of the junction box onto the proper ECU.

Basic Control Principles

- Switching on the ECU
- Layout of the Work Screen
- Control Units

Switching on the ECU

WARNING – Risk of injury from moving machine parts

- Movement of the machine may seriously injure persons or damage property.
- Before activating the ECU, make sure that no one is close to moving machine parts.

1. Connect the ISOBUS cable of the ECU to the ISOBUS connector on the tractor.
2. Start the ISOBUS terminal.

The ECU is started together with the terminal.

When starting up for the first time, the ECU initially has to transmit lots of information to the terminal. This can take a few minutes.

When all of the data from the ECU app has been loaded, the icon for the app appears on the terminal:



3. Open the ECU app. Follow the instructions for the ISOBUS terminal.

The work screen of the ECU appears.

Layout of the Work Screen

The work screen is always shown during work and informs you of the status of the field sprayer.

The work screen is divided into several areas. In each area, information on specific topics may appear.

With the configuration of the ECU, the areas can be changed by the field sprayer manufacturer for a specific field sprayer model. For this reason, the following graphs only show the standard version of the overview.

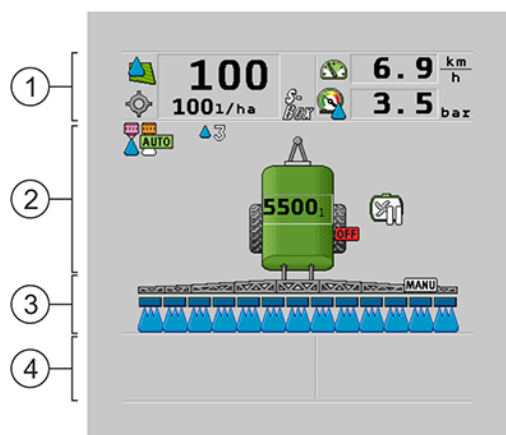











Areas on the work screen

Item	Description	Item	Description
1	Spray data area	3	Boom area

Item	Description	Item	Description
2	Implement image with icons	4	Icons beside the implement image





You can read about the information that appears in these areas in the following sections. Function icons appear beside the work screen, which perform functions when they are tapped. Their position and operation depend on the type of ISOBUS terminal.















In the table below, you can see the meaning of the function icons on the work screen.

Icon	Function	Icon	Function
	Opens the "Results" screen.		Shows the next page with function icons.
	Opens the "Parameters" screen.		Switches between two levels of icons, if an additional water sensor is configured.
	Opens the "Tank Filling" screen.		Switches between two levels of icons.
	Opens the "Folding" screen.		Starts and stops the drawbar or axle steering.
	Switches between manual and automatic regulation of the application rate.		Opens a screen with additional functions.

Spray data area

Depending on the configuration, the following icons may appear:

Icon	Meaning	Icon	Meaning
	<p>The application rate will be automatically regulated. An additional number can appear on the icon. This number indicates the pre-set density.</p> <p>The current value (current application rate) appears next to it. If you are working with band spraying, the icon for the application rate changes accordingly:</p> 		The bar graph only appears when the target rate is changed in automatic mode using the +10% and -10% buttons. It shows the deviation from the original target rate.
	<p>No flow. The main valve cannot be opened because one of the requirements has not been fulfilled:</p> <ul style="list-style-type: none"> • Speed slower than • Section status • Target rate out of reach • SECTION-Control has terminated the application 		Trip counter is deactivated.

Icon	Meaning	Icon	Meaning
	The application rate will be automatically regulated. The target rate appears next to it.		The sprayer functions will be switched on and off through an "S-Box".
	The application rate will be manually regulated.		The target rate is defined by an external source: Task Controller, prescription map, external sensor, etc.
	Automatic mode is deactivated. The flow will not be regulated. The current speed is lower than the "Regulation off below" parameter and higher than "Sprayer off below"		<ul style="list-style-type: none"> A problem has occurred with the transmission of the target rate from an external source. The sprayer is outside of the area defined in the prescription map or in an area that should not be sprayed.
	Simulated speed activated.		The vehicle is driving in reverse.
	Speed. If the numbers are red, it means that the regulation or the application have been interrupted because the speed is too low.	  <i>(background is flashing)</i>	<p>The speed signal from the tractor / ISOBUS cannot be adopted. The system will now determine the speed using the sensor connected to the junction box.</p> <p>Ensure that the number of impulses per 100m is correctly entered. The icon can only appear if the signal source was automatically selected.</p>
	Pressure control is active.		The pressure measured by the pressure sensor is too low compared to the flow measured by the flow meter.
	Pressure. Per default, the pressure is determined by a pressure sensor. If there is no pressure sensor, a calculated pressure can be shown.		

Boom Display Area

In the boom display you find the following information:

- Number of sections
- Which sections are preselected or switched off
- Which sections are applying

The diagrams below show how the sections may appear in the boom display area:

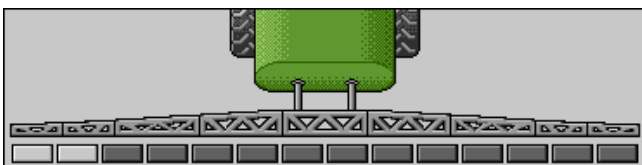

Sections 1 and 2 are closed and deactivated.

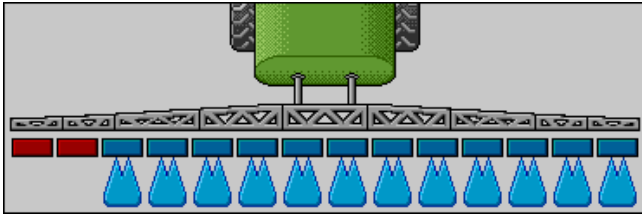

Sections 1 and 2 are closed. All of the other sections are open and spraying.

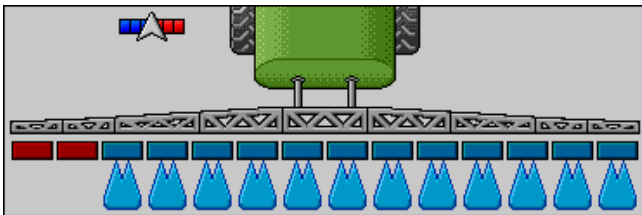

When SECTION-Control is activated, the SECTION-Control icon also appears.

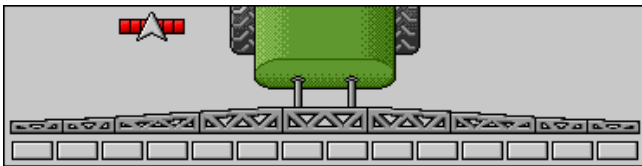

If SECTION-Control is not possible, the colour of the SECTION-Control icon changes.



Each rectangle corresponds to a section valve.

Section Status

Picture	Status of the section valve	Status of the control/main valve
	Closed valve	Closed valve
	Opened valve	Closed valve
	Opened valve	Opened valve
	Closed valve	Opened valve
	The section is permanently deactivated	

When the sections are automatically switched using SECTION-Control, you have to ensure that the sections are not deactivated using an S-Box or a joystick. In this case, the section would be marked with a red cross and remain closed.

Section Status with SECTION-Control and with S-Box











Picture	Status defined by SECTION-Control	Status of the control/main valve	Status via S-Box or joystick
	Opened valve	Opened valve	Closed valve
	Opened/closed valve	Closed valve	Closed valve

Field sprayers with EDS (single nozzle switching) do not have section valves. One section consists of multiple nozzles that are switched by EDS modules. The section icon is divided into several segments. Each segment represents one nozzle.







Section Status with EDS







Picture	Nozzle A	Nozzles B, C, D
	Open nozzle	Closed nozzle

Icons Beside the Implement Image



Functions			
Icon	Meaning	Icon	Meaning
	Sections are switched via SECTION-Control.		The SECTION-Control application has closed all sections. Examples for the cause (Other causes are also possible): <ul style="list-style-type: none"> The sprayer is outside of the field boundary or in an area that has already been worked. Sprayer on the headland.
	Beacon is switched on.		Nozzle lighting is switched on.
	The working lights are switched on. If a second working light is used, it is shown by a number.		Reversing light is switched on.
	The mixing hopper lighting is switched on.		Stirrer is working.
 (flashing)	Stirrer has been stopped. Cause: Fill level is too low.		Fresh water is being filled into the main tank.











Functions			
Icon	Meaning	Icon	Meaning
 (not flashing)	Stirrer has been stopped. Cause: Stopped by the driver.		Fresh water is being transferred.
	Tank internal cleaning is activated.		Low-pressure cleaner is being used.
	High-pressure cleaner is being used.		The ring line is being rinsed.
	Mixing hopper is being lifted.		Mixing hopper is being lowered.
	Nozzles used in Vario mode.		Intended drop size with Airtec or in Vario mode.
	Nozzles used in Select mode.		The pressure is being increased.
	Nozzle cleaning activated.		The pressure will be increased by the pre-set pressure setpoint for the booster pump.
	Pump switched on.		Fan switched on.
	Pump switched off.		Fan switched off.
	Permanent tank internal cleaning is activated.		Filter rinsing is activated.
	Filter rinsing is activated and being used.		Compressed air rinsing is being used.
	The support leg is being lowered.		The support leg is being raised.
	The corresponding unit of the Raven injection system is active.		The corresponding unit of the Raven injection system is deactivated.
	The corresponding unit of the Raven injection system is not connected or not ready for operation.		CURVE-Control is activated.













Airtec Icons	
Icon	Meaning
	Current air pressure
	System is increasing the air pressure.
	System is reducing the air pressure.
	Air compressor is off.
	Air compressor is on.
	Manual mode is activated. The number indicates the drop size.
	Drop size (automatic mode activated).

Counters and Sensors	
Icon	Meaning
	Wind strength
	Output in litres per minute
	Area output per hour
	The output per minute measured by the flow meter is too low compared to the output calculated by the pressure sensor.
	Fan speed
	Pump speed
	Can also be used to indicate whether a pump is switched on or off.

Icons on the Implement Image

General icons	
Icon	Meaning
	<p>Tank counter:</p> <ul style="list-style-type: none"> • Current fill level (l) • Area that can be sprayed until the tank is empty (ha) • Distance that can be driven until the tank is empty (km) • Acid content in the tank (pH)
	Ring line circulation function switched on.

Boom	
Icon	Meaning
	Display of the current boom slope.
	DISTANCE-Control is installed, but is deactivated. The boom has to be controlled manually.
	DISTANCE-Control lifts the boom.
	Boom lifting aborted because a critical upper boom height has been reached.
	DISTANCE-Control lowers the boom.
	Boom lowering aborted because a critical lower boom height has been reached.
	Spot spraying is activated, but a CAN repeater was not detected.
	Spot spraying is activated and a CAN repeater was detected, but no signal is being transmitted from a camera.
	Spot spraying is activated and all nozzles should be closed.
	Spot spraying is activated and some of the nozzles should be closed.

TRAIL-Control		
Meaning	Icons for drawbar steering	Icons for axle steering
No TRAIL-Control.		
TRAIL-Control is installed but is deactivated.		
TRAIL-Control is in manual mode.		
TRAIL-Control is in automatic mode.		
The drawbar is locked with a pin.		
The implement is being steered to the left.		
The implement is being steered to the right.		

Control Units

The following options are available for operating the ECU:

- Using the function buttons on the screen
- Using AUX-N operating devices
- Using the PTx joystick
- Using the PTx S-Box
- Using an external keypad

Operating the ECU on the Field

- Tank Filling
- Controlling the Boom
- Starting the Application
- Regulating the Application Rate
- Operating Sections
- Documenting Work Results
- Using Pressure Registration
- Setting the Rotational Speed
- Operating the PTx Joystick
- Using Foam Markers
- Operating Additional Functions
- Regulating Drop Size with AIRTEC
- Using ISB Short-Cut Button
- Trailed Implement with Dual Axles
- Stirring Control
- TC-GEO Management

Tank Filling

The desired type of tank filling depends on the additional equipment that is installed on your sprayer. The filling procedure can differ depending on the additional equipment.

The following filling methods are available:

- Filling the tank manually without additional systems
- Filling the tank with TANK-Control
- Filling the tank with integrated TANK-Control III

There are also the OEM-specific filling methods TANK-Control II and TANK-Control III. You can obtain more information about this from the respective manufacturers.

Regardless of the filling method, the filling procedure is always performed through the filling screen.

This is how you reach the screen with this function:



Filling the Tank Manually without Additional Systems



If you are filling the tank without additional systems and you are also not using a filling pump or fill stop, you can enter the tank content manually.



1.  - Switch to the "Filling" screen.
2. For the "New tank content" parameter, enter the tank content after the filling.

or



Alternatively:  - Enter full tank,  - Enter empty tank.





The new tank content appears on the screen.

Filling the Tank with Filling Pump

If you are filling the tank without additional systems, but are using a filling pump for the filling procedure, proceed as follows:



1.  - Switch to the "Tank filling" screen.
2.  - Switch on the pump to start filling the tank.

During the filling procedure, the following icon appears on the screen:





3.  - Switch off the pump when the tank is full.

The new tank content appears on the screen.

Filling the Tank with Fill Stop

Filling with a Fill Stop

If a fill stop has been installed and configured on the sprayer, you can use it. The tank filling will then be terminated either manually or automatically when the refilling limit has been reached.

1.  - Switch to the "Filling" screen.
2.  - Start filling.

or



- 
- Stop filling manually.

The tank is filled until the refilling limit has been reached or the filling procedure is interrupted manually.

The new tank content appears on the screen.

Filling with Fill Stop and Fill Stop Switch

When a fill stop and a fill stop switch are installed and configured on the sprayer, you can start and stop the filling procedure either via the terminal or using the fill stop switch. The filling will then be terminated either manually or automatically when the refilling limit has been reached.

1.  - Switch to the "Filling" screen.
2.  - Start filling.

or



- 
- Stop filling manually via the terminal or by pressing the fill stop switch.

The tank is filled until the refilling limit has been reached or the filling procedure is interrupted manually.

The new tank content appears on the screen.

Filling with Two Fill Stops

If the sprayer operates with two tanks and a fill stop is installed and configured on each tank, you can use them independently of one another. The filling will then be terminated for the respective tank either manually or automatically when the refilling limit has been reached.

1.  - Switch to the "Filling" screen.
2.  - Select the tank that you want to fill.

3.  - Start filling.

or

-  - Stop filling manually.

The tank is filled until the refilling limit has been reached or the filling procedure is interrupted manually.

During the filling procedure, the respective icon appears on the screen:





4. Repeat the filling procedure for the other tank. If you switch from one tank to the other while filling, the filling procedure will be automatically interrupted.

The new tank content appears on the screen.

Filling with One Fill Stop and Tank Selection

If the sprayer operates with two tanks and a fill stop is installed and configured on one of the tanks, you must select the tank on which the fill stop will be used. The filling will then be terminated for the selected tank either manually or automatically when the refilling limit has been reached.

1.  - Switch to the "Filling" screen.

2.  - Select the tank on which the fill stop will be used.

3.  - Start filling.

or

-  - Stop filling manually.

The tank is filled until the refilling limit has been reached or the filling procedure is interrupted manually.

4. During the filling procedure, the respective icon appears on the screen:



The new tank content appears on the screen.

Filling the Tank with TANK-Control I

Filling the Tank with a Filling Pump or Filling Tap

If you are filling the tank with TANK-Control and a filling pump or filling tap, proceed as follows:

1.  - Switch to the "Filling" screen.

2.  - Start filling.

During the filling procedure, the following icon appears on the screen:

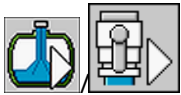

During the filling procedure, the new tank content will appear on the "Current tank content" line.

3.  - Stop filling.

The new tank content appears on the screen.

Filling the Tank with a Single Fill Stop

If a TANK-Control with fill stop has been installed and configured on the sprayer, you can use it. It will stop the filling automatically when a specified fill level is reached.

1.  - Switch to the "Filling" screen.
2. Set the "Refilling limit" parameter.

3.  - Start filling.

During the filling procedure, the following icon appears on the screen:



When the fill level defined as "refilling limit" is reached, filling will be terminated.

Filling the Tank with Two Fill Stops

If TANK-Control with two fill stops are installed and configured on the sprayer, you can use them independently of one another. The filling will then be automatically terminated for the respective tank when the refilling limit has been reached.

1.  - Switch to the "Filling" screen:
2. Under "Refilling limit", you can enter up to two refilling limits at which the filling pump should be stopped.

If you enter two refilling limits, a new function icon appears on the screen:



Press the  icon to mark a refilling limit at which the pump should be stopped.

3.  - Start filling.

During the filling procedure, the following icon appears on the screen:



Filling starts.

When the fill level defined as refilling limit 1 is reached, filling will be terminated.

If there is a second refilling limit, it will be automatically activated.

4. You can now add the spray agent and stir the tank contents.
5. Prepare the sprayer for the second filling.

6.  - Start filling.

Filling starts.

When the fill level defined as refilling limit 2 is reached, filling will be terminated.

Filling with Fill Stop and Alarm

If TANK-Control with fill stop and an alarm function are installed and configured on the sprayer, you can use them. It will stop the filling automatically when a specified fill level is reached. In addition, an alarm is issued at a selected fill level.

1.  - Switch to the "Filling" screen.
2. Set the "Refilling limit" parameter.
3. Set the "Refilling limit" parameter for the alarm.
4. Select the duration of the alarm.

5.  - Start filling.

During the filling procedure, the following icon appears on the screen:





As soon as the alarm limit is reached, an alarm is issued for the specified duration.

When the fill level defined as "refilling limit" is reached, filling will be terminated.

Filling with Fill Stop, Alarm, and Automatic Fresh Water Transfer

If TANK-Control with fill stop and an alarm function are installed and configured on the sprayer, you can also use them with an automatic fresh water transfer. It will stop the filling automatically when a specified fill level is reached. In addition, an alarm is issued at a selected fill level. Moreover, you can automatically transfer fresh water to the main tank.

1.  - Switch to the "Filling" screen.
2. Set the "Refilling limit" parameter.
3. Set the "Refilling limit" parameter for the alarm.
4. Select the duration of the alarm.
5. Set the "Water amount" parameter for the fresh water transfer.

6.  - Start filling.
7. During the filling procedure, the following icon appears on the screen:



8.  - Start the automatic fresh water transfer during the filling procedure.
9. The following icon appears:

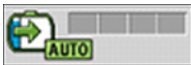

The bar graph shows the current status of the fresh water transfer.



The icon disappears as soon as the fresh water transfer is completed.

As soon as the alarm limit is reached, an alarm is issued for the specified duration.

When the fill level defined as "refilling limit" is reached, filling will be terminated.

Filling the Tank with Automatic Fresh Water Transfer

You can perform an independent automatic fresh water transfer through the filling screen.

1.  - Switch to the "Filling" screen.
2.  - Start the automatic fresh water transfer.

The following icon appears:



The bar graph shows the current status of the fresh water transfer.

The icon disappears as soon as the fresh water transfer is completed.

Filling the Tank with Integrated TANK-Control III

Filling the Tank with Filling Pump

If you are filling the tank with an integrated TANK-Control III and a filling pump, proceed as follows:

1.  - Switch to the "Filling" screen.

2.  - Start filling.

During the filling procedure, the following icon appears on the screen:



During the filling procedure, the new tank content will appear on the "Current tank content" line.

3.  - Stop filling.

The new tank content appears on the screen.

Filling the Tank with a Single Fill Stop

If an integrated TANK-Control III with fill stop is installed and configured on the sprayer, you can use them. It will stop the filling automatically when a specified fill level is reached.

1.  - Switch to the "Filling" screen.
2. Set the "Refilling limit" parameter.

3.  - Start filling.

During the filling procedure, the following icon appears on the screen:



When the fill level defined as "refilling limit" is reached, filling will be terminated.

Filling the Tank with Two Fill Stops

If an integrated TANK-Control III with two fill stops are installed and configured on the sprayer, you can use them independently of one another. The filling will then be automatically terminated for the respective tank when the refilling limit has been reached.

1.  - Switch to the "Filling" screen:

2.  - If the sprayer has two tanks, select the tank that you want to fill.

- Under "Refilling limit", you can enter up to two refilling limits at which the filling pump should be stopped.

If you enter two refilling limits, a new function icon appears on the screen:



Press the  icon to mark a refilling limit at which the pump should be stopped.

-  - Start filling.

During the filling procedure, the following icon appears on the screen:



Filling starts.

When the fill level defined as refilling limit 1 is reached, filling will be terminated.

If there is a second refilling limit, it will be automatically activated.

- You can now add the spray agent and stir the tank contents.
- Prepare the sprayer for the second filling.





-  - Start filling.

Filling starts.

When the fill level defined as refilling limit 2 is reached, filling will be terminated.

Filling with Fill Stop and Alarm

If an integrated TANK-Control III with fill stop and an alarm function are installed and configured on the sprayer, you can use them. It will stop the filling automatically when a specified fill level is reached. In addition, an alarm is issued at a selected fill level.

-  - Switch to the "Filling" screen.
-   - If the sprayer has two tanks, select the tank that you want to fill.
- Set the "Refilling limit" parameter.
- Select the duration of the alarm.
-   - Start filling.

During the filling procedure, the following icon appears on the screen:





As soon as the alarm limit is reached, an alarm is issued for the specified duration.

When the fill level defined as “refilling limit” is reached, filling will be terminated.

Filling with Fill Stop, Alarm, and Automatic Fresh Water Transfer

If an integrated TANK-Control III with fill stop and an alarm function are installed and configured on the sprayer, you can also use them with an automatic fresh water transfer. It will stop the filling automatically when a specified fill level is reached. In addition, an alarm is issued at a selected fill level. Moreover, you can automatically transfer fresh water to the main tank.

1.  - Switch to the “Filling” screen.
2.  - If the sprayer has two tanks, select the tank that you want to fill.
3. Set the “Refilling limit” parameter.
4. Select the duration of the alarm.
5. Set the “Water amount” parameter for the fresh water transfer.
6.  - Start filling.

During the filling procedure, the following icon appears on the screen:



7.  - Start the automatic fresh water transfer during the filling procedure.

The following icon appears:

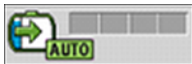

The bar graph shows the current status of the fresh water transfer.



The icon disappears as soon as the fresh water transfer is completed.

As soon as the alarm limit is reached, an alarm is issued for the specified duration.

When the fill level defined as “refilling limit” is reached, filling will be terminated.

Filling the Tank with Automatic Fresh Water Transfer

You can perform an independent automatic fresh water transfer through the filling screen.

1.  - Switch to the “Filling” screen.
2.  - Start the automatic fresh water transfer.

The following icon appears:



The bar graph shows the current status of the fresh water transfer.

The icon disappears as soon as the fresh water transfer is completed.

Controlling the Boom

In this section you learn how to control the boom using the terminal.

DANGER! INJURY TO PERSONS THROUGH IMPROPER OPERATION

EVERY FIELD SPRAYER IS DESIGNED DIFFERENTLY AND MUST BE OPERATED DIFFERENTLY. IN THIS SECTION, ONLY THE ICONS THAT APPEAR ON THE SCREEN OF THE TERMINAL CAN BE EXPLAINED.

READ THE FIELD SPRAYER OPERATING GUIDE.

LEARN THE SEQUENCE IN WHICH YOUR FIELD SPRAYER MUST BE OPERATED SAFELY.

Lifting and Lowering the Boom

This is how you reach the screen with this function:



To operate this function, the user needs the PTx joystick first of all.

Use the following function keys to operate the function:

Function icon	Function
	Lifts the boom.
	Lowers the boom.
	Activates and deactivates DISTANCE-Control.

On the following diagram you see how this function is shown on the work screen:

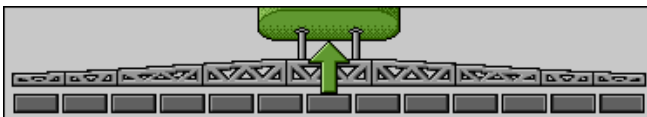

Boom is being lifted - the arrow in the middle shows the direction

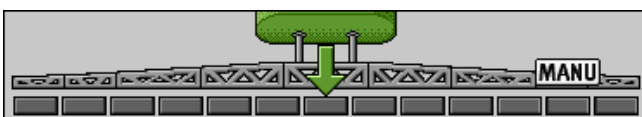

"MANU" means that DISTANCE-Control is deactivated and the boom must be raised and lowered manually.

Folding and Unfolding the Boom

This function folds the field sprayer boom in and out.

Operation depends on the following factors:

- Number of boom parts that can be folded in and out.
- Type of locking for the folding in and out of the boom.
- Type of field sprayer.

This is how you reach the screen with this function:



Structure of a Boom

The following diagram shows the structure of booms and what the individual boom parts are called. The diagram shows a field sprayer with a seven-part boom, but it also applies to smaller booms.

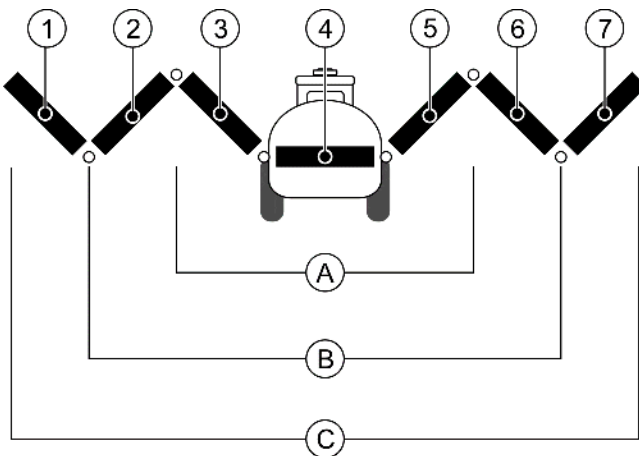

Parts of the boom on a field sprayer

Item	Meaning	Item	Meaning
A	Three-section boom	3	Boom part: Inner left
B	Five-section boom	4	Boom part: Unmoving part
C	Seven-section boom	5	Boom part: Inner right
1	Boom part: Outer left	6	Boom part: Middle right
2	Boom part: Middle left	7	Boom part: Outer right

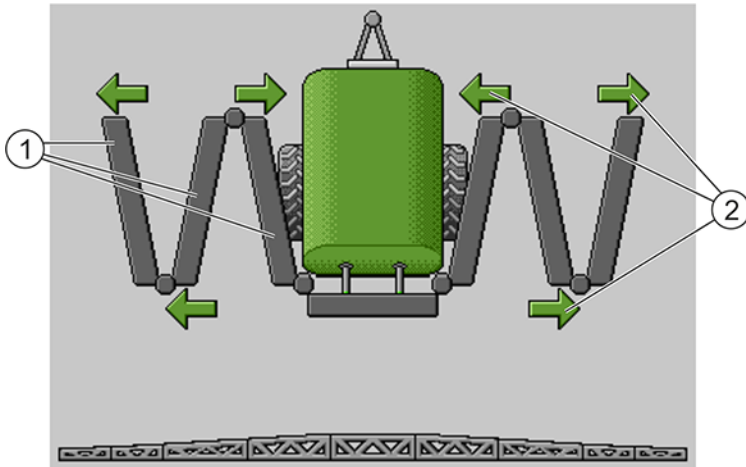

Representation of the boom on the “Boom folding” screen

Item	Meaning
1	Folding parts of the boom
2	Icon: Boom section is being folded in or out The arrows appear for folding boom sections and indicate the direction of movement.

Icon	Meaning
	The boom is at the same height as the boom top height sensor. Requirement: The boom top height sensor is installed.

On the following diagram, you see how a seven-part boom is shown on the function icons.

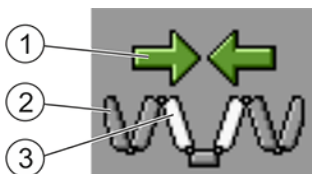

Item	Meaning
1	Directional arrow Arrow pointing inwards means: Fold in Arrow pointing outwards means: Fold out
2	Sections of the boom marked in grey are not folded in or out with this function icon
3	Sections of the boom marked in white are folded in or out with this function icon

Use the following function keys to operate the function:

Function	Three-section boom	Five-section boom	Seven-section boom
Fold inner boom symmetrically			

Function	Three-section boom	Five-section boom	Seven-section boom
Unfold inner boom symmetrically			
Fold boom in the middle symmetrically			
Unfold boom in the middle symmetrically			
Unfold outer left boom			
Unfold outer right boom			
Fold inner and middle boom symmetrically			
Unfold inner and middle boom symmetrically			
Block boom section			

Locking the Boom

This function enables locking and unlocking of the boom.

This is how you reach the screen with this function:



Use the following function keys to operate the function:

Icon	Meaning
	Locks the boom.
	Unlocks the boom.
	The boom is being locked. The procedure is not completed.
	The boom is being unlocked. The procedure is not completed.
	The boom is locked.
	The boom is unlocked.

Raising and Lowering the Wings (tilting up / down)

The system is capable of raising or lowering wings independently or simultaneously.

This is how you reach the screen with this function:



Use the following function keys to operate the function:

Icon	Function
	Raises the right wing.
	Raises the left wing.
	Lowers the right wing.
	Lowers the left wing.
	Raises both wings symmetrically.
	Lowers both wings symmetrically.

1. Press the function key with the desired function.
The wings will be moved.
2. Keep function button pressed until the boom reaches the desired angle.
3. Release function key.

Sloping the Boom

This is how you reach the screen with this function:



To operate this function the user needs the PTx joystick first of all.

Use the following function keys to operate the function:

Icon	Function
	Slopes the boom to the right. It will be raised on the left.
	Slopes the boom to the left. It will be raised on the right.

On the following diagram you see how this function is shown on the work screen:



Slope boom: raise on the left, lower on the right



Slope boom: lower on the left, raise on the right

Reproducing the Boom Slope When Turning

This function assists you when working on slopes.

The boom is sloped when working on a hillside. The function saves the angle of slope.

After a turning manoeuvre, the angle of slope is reproduced when the field sprayer is travelling in the opposite direction.

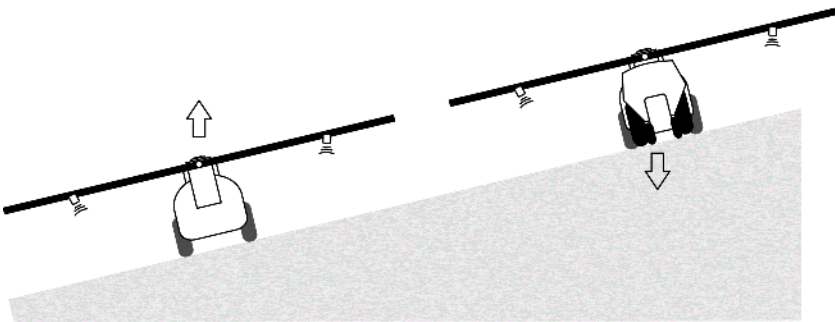

When turning on a slope, you can press a button to slope the boom in the opposite direction.

Use the following function keys to operate the function:



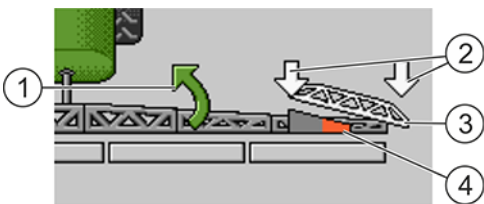

Icon	Meaning
	Activates the function. Each time the button is pressed, the target position of the boom (white arrows) changes.
	Slopes the boom manually. By pressing this button, the automatic reproduction of the slope angle is terminated.

When the function is active, the current setting is shown above the boom on the work screen.



Item	Meaning	Item	Meaning
1	Current direction of movement of the boom.	3	Current boom position.
2	Target boom position.	4	Current angle of the angle sensor on the sloping cylinder.

Depending on the configuration, the following icons may appear:

Icon	Meaning
	White arrows: Target position is horizontal. Angle sensor: Horizontal position has been reached.
	Boom is sloped to the right. Function is deactivated.
	Boom is sloped to the right. However, it should be automatically sloped to the left. The system will move the boom in this direction. Current position: Boom is sloped to the right Target position: Sloped to the left. Reproduce boom angle: activated
	Boom is sloped to the right. However, it should be automatically moved to a horizontal position. The system will move the boom in this direction.

Before you begin, make sure you have calibrated the boom potentiometer (slope angle sensor).

1. Drive across the slope gradient with the field sprayer.
2. Position the boom parallel to the sloped ground.
3.  - Press on the headlands before the turning manoeuvre.

The current angle will be saved.





- Two white arrows pointing down appear.

The system returns the boom to the horizontal position.

While the boom is moving, a green arrow appears on the work screen.

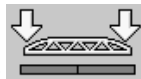

When the boom is horizontal, the  icon appears.

4. Turn only when the boom is horizontal.
5.  - Press once after the turning maneuver.





The ECU slopes the boom in the opposite direction until the previously saved angle is reached on the other side.

While the boom is moving, a green arrow appears on the work screen.

The function switches off if you change the boom angle manually.

Using Additional Boom Sensors

If you are using additional boom sensors and these sensors detect a specific state, this will be shown on the work screen.

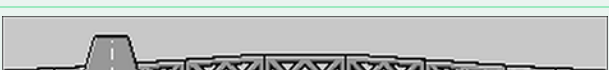
Icon	Meaning
	Boom height
	Transport position – When this state is detected, the boom cannot be lowered or folded.
	Slope middle position
	The telescopic boom is in the end position. When the icon appears, the hydraulic function will be stopped.
	The telescopic boom is in road mode. When the icon appears, the hydraulic function will be stopped.
No icon on the work screen.	Boom folded – This sensor deactivates sections when a pre-set position has been reached.
No icon on the work screen.	Boom unfolded – This sensor deactivates sections when a pre-set position has been reached.

Starting the Application

Before you begin:

- The tractor with the field sprayer is on the field.
- You have configured the ECU.
- You have folded out the boom.

1. Ensure that all prerequisites have been fulfilled.



2. - Start application

- Manual mode: The field sprayer starts the application.
- Automatic mode: The sprayer will be prepared for application.

As long as the sprayer is not moving, the following icon appears on the work screen, depending on the “Sprayer off below:” parameter:



3. If you are in automatic mode, start driving and exceed the minimum speed for the automatic regulation (parameter: “Regulation off below”).

As long as the field sprayer is not regulating, the following icon appears on the work screen, depending on the “Regulation off below:” parameter:



As soon as the minimum speed is exceeded, the field sprayer starts regulating.

You have started the application.

Immediate Application

There may be situations where you want to start spraying while the sprayer is still at a standstill. For example, when you have stopped on the field.

To start immediate application in automatic mode:

- The tractor with the field sprayer is on the field.
 - You have configured the ECU.
 - You have folded out the boom.
 - Automatic mode is activated.
1. Press and hold the application button on the joystick for three seconds.
 2. The field sprayer starts the application.

Spray cones appear under the boom icon:

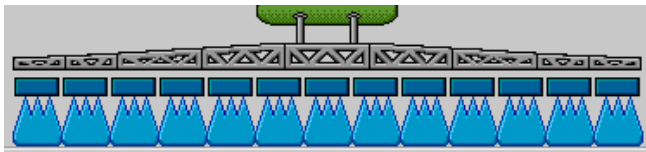

3. Start driving within 5 seconds and exceed the minimum speed for the automatic regulation (parameter: "Sprayer off below"). Otherwise, the application will be automatically terminated.

Regulating the Application Rate

Types of regulation:

Depending on the sprayer equipment, the application rate regulation system can either control the opening of a control valve or the speed of a centrifugal pump.

Work modes:

You can regulate the application rate manually or you can leave the regulation to the ECU:

- In manual mode, you can control the opening of the control valve with two buttons.
- In automatic mode, the ECU regulates the opening of the control valve (or the pump speed) such that the application rate defined as the set rate is reached.

Use the following function keys to operate the function:

Icon	Function
	Switches the mode between manual and automatic.

You will learn how to operate the system in the following sections.

Changing the Application Rate in Manual Mode

When the field sprayer is in manual mode, the application is not regulated according to a specified rate. The application rate must be set manually instead.

The application rate must be regulated manually when the following icon appears in the spray data area of

the work screen: 





Application in manual mode

Please note that the pressure is also automatically changed when you change the application rate.

To operate this function the user needs the PTx joystick first of all.





Use the following function keys to operate the function:

Icon	Function
	Increases the application rate.
	Reduces the application rate.

Using Automatic Mode

In automatic mode, the ECU regulates the degree of opening of the control valve and the main valve on the manifold such that the target rate defined for the application rate can be reached.

You are in automatic mode when one of the following icons appears in the spray data area of the work screen:

Icon	Meaning
	Sprayer can apply.
	The speed of the sprayer is lower than "Regulation off below" Sprayer can apply. The flow will not be regulated. The control valve remains in the last known position until the speed changes.
	The speed of the sprayer is lower than "Sprayer off below" The main valve is closed automatically.
	Regulation is not possible because the application was deactivated by the SECTION-Control app.

To use automatic mode, the following conditions must be fulfilled:

- Target rate has been entered.
- Flow meter is calibrated.
- A speed signal is available.
- Working width is set.
- The speed of the field sprayer is higher than the speed for the “Regulation off below” parameter.
- The parameter “Regul. factor” has been set.







In the following cases, the flow is automatically adjusted:

- Speed of the sprayer has changed.
- Number of switched-on sections has changed.
- You have changed the target rate manually.
- The application rate has been changed by the information from the application map.



The speed and precision of the regulation depends on the value of the “Regul. factor” parameter.

You can change the target rate manually while driving in Automatic mode.



To operate this function the user needs the PTx joystick first of all.

Icon	Function
	Increases the target rate by 10%.
	Reduces the target rate by 10%.
	Restores the target rate back to 100%.
	Changes to the entered “Rate 1”.
	Changes to the entered “Rate 2”.
	Increases the pressure.
	Increases the pressure by a previously defined value.

To change the target rate during work:



1.  - Activate automatic steering.
2.  - Open main valve.

Spray cones appear under the boom icon on the work screen. Still, the sprayer is not spraying.

As long as you are at a standstill, the sprayer cannot start spraying. See icons:  and .

3. Exceed the speed defined in the “Regulation off below” parameter.

The sprayer begins adjusting the application rate to the defined target rate.

4.  or  - Press to change the target rate.



The degree of change appears on the work screen.

5.  - Restores the original target rate.

6. If you have entered several target rates in the configuration, you can also use the function icons: 

and  to switch among the target rates.

To change the target rate during work:

- a.  - Activate automatic steering.
- b.  - Open main valve.

Spray cones appear under the boom icon on the work screen. Still, the sprayer is not spraying.

As long as you are at a standstill, the sprayer cannot start spraying. See icons:



- c. Exceed the speed defined in the “Regulation off below” parameter.
- d. The sprayer begins adjusting the application rate to the defined target rate.

- e.  or  - Press to change the target rate.

The degree of change appears on the work screen.

- f.  - Restores the original target rate.

Setting Target Rate

The target rate is the quantity of spray liquid you want to apply per hectare.

The ECU will attempt to maintain this rate during the work.

There are several ways to specify the rate:

- Enter rate on the “Parameters” screen.
- The target rate can be adopted from external sources using the “ISOBUS-TC” app:
 - from tasks,
 - from prescription maps,
 - from external sensors.



Target rate from parameters



Target rate from an external source

Target rates from external data sources have a higher priority than the target rate entered in the ECU. For this reason, you do not have to adjust the “Rate” parameter when you are working with prescription maps.

As an option, you can enter up to three different target rates in the ECU. To do so, use the “Rate 1” and “Rate 2” parameters in addition to the “Target rate” parameter.

Stopping Application

You can stop application in the following ways:

- - Close main valve.
- or - Close the section valves consecutively.
- Drive slower than the set minimum speed (only in automatic mode).

Operating Sections

To operate this function the user needs the PTx joystick first of all.

Use the following function keys to operate the function:

Icon	Function
	Closes section valves from left to right.
	Closes section valves from right to left.
	Opens section valves from left to right. or When all of the section valves are closed, then the first section valve is opened from the left.
	Closes section valves from right to left. or When all of the section valves are closed, then the first section valve is opened from the right.
	If the sections were deactivated via SECTION-Control, press and hold for approx. 3 seconds to override the deactivation of the sections. The sections are then opened for approx. 5 seconds. On the work screen, check marks appear at the respective sections for the 5 seconds.

If your implement has an external main switch, you can use it to open or close all of the sections.

Documenting Work Results

You can document your work in the “Counters” screen.

On the “Results” screen, there are two types of counter:

- Trip counter – documents the work until it is deleted.
- Total counter – documents the work since initial start-up.

You can find various information on the “Results” screen. Depending on the configuration and equipment of the implement, different work results can appear.

- **Quantity** – Applied quantity.
- **Work time** – Duration of the application.
- **Distance** – Distance driven during the application.
- **Area** – Applied area.

This is how you reach the screen with this function:



Use the following function keys to operate the function:

Icon	Function
	Resets the “Volume” counter.
	Resets the “Area” counter.
	Resets the “Distance” counter.
	Resets the “Work time” counter.
	Pressed briefly: Continue to the total counters Pressed long: Back to the work screen
	Clears the contents of the displayed trip counter.
	Stops the trip counter. - The documentation of the work will be stopped until the terminal is restarted or the function button is pressed again. - The icon is flashing on the work screen:
	Next trip counter. (Optional function)
	Activates the trip counter. (Optional function)

Icon	Function
	Previous trip counter. (Optional function)

Using Pressure Registration

The ECU measures the respective current spray pressure every 10 seconds for documentation purposes.

You can view the measured values via the ECU.

This is how you reach the screen with this function:

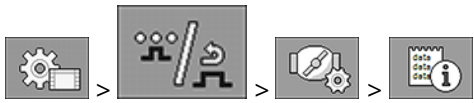

Procedure

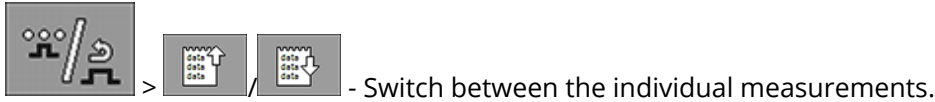

You can always view the pressures measured in the last hour. The respective pressure is measured every 10 seconds when the sprayer is switched on.

Setting the Rotational Speed

If the pump or the fan works with RPM control, you can control it during operation. In doing so, the configured rotational speeds are always used as the speeds.



If you configured rotational speeds for the headlands, cleaning and filling, they will automatically be used for the respective task.



This is how you reach the screen with this function:



Use the following function keys to operate the function:

The table shows the function systems that are displayed when controlling the rotational speed of a pump. For a fan, the function icons change accordingly.

Icon	Function
	RPM control will be started.
	RPM control will be stopped.
	Default rotational speed 1 will be used.

Icon	Function
	Default rotational speed 2 will be used.
	Manual rotational speed will be used.



Operating the PTx Joystick

With the PTx joystick, you can activate and deactivate the sprayer functions. For example:

- Open main valve
- Switch off sections from left to right
- Lifting and lowering the boom manually

Side-Mounted Switch

Three functions are assigned to each button. The position of the side switch determines the function that is executed when a button is pressed.

Position of the switch	LED Color
	Red
	Yellow
	Green

The button assignment depends on the configuration of the sprayer.

Before you begin to operate the PTx joystick, make sure the work screen is called up.

1. Move the side switch into the desired position and hold.
The LED on the PTx joystick lights up in the corresponding color.
2. Press the button with the desired function.
The function is executed.

Preview Mode for the PTx Joystick

The preview mode of the joystick can only be used when your joystick works with the AUX1 auxiliary protocol.

When pressing the button for the first time, the preview mode shows the button assignment on the screen. This makes it easier for beginners to activate the right function. As a standard, preview mode is deactivated on new ECUs.

Mode of Operation

When you press a joystick button for the first time after starting, no function will be executed. The button assignment of the joystick appears on the screen instead. The display remains until the time set in the configuration has expired.

If you press a joystick button during the display, its function will be executed. (Assignment remains on the screen until the time expires).

From now on, you can operate the joystick without the help display appearing.

The help display only appears again if you press a button and simultaneously move the rocker switch on the side to a different position.

Procedure

To activate the preview mode:

1. Switch to the "Parameters" screen:



2. For the "PTx Joystick" parameter, set the value to "PTx Joystick".



The "Joystick assistant" parameter appears.

3. Set the check mark for the parameter.
4. If necessary, change the display time.

Viewing the Assignment of the PTx Joystick

The assignment of the joystick can only be viewed when your joystick works with the AUX1 auxiliary protocol.

Before you begin to display the button assignment on the screen, make sure the PTx Joystick is configured.

1.  - Press until the  button appears.
2.  - Press.

The button assignment appears:

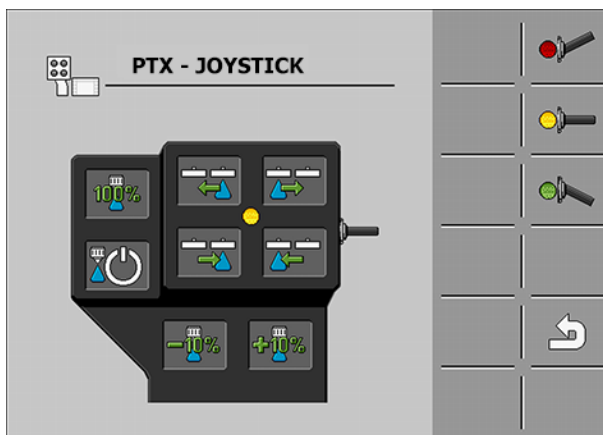

3.  - Press to view the assignment on each level.
4. You can also activate the Preview mode.



Using Foam Markers

Foam markers produce foam that can be applied by the field sprayer driver on the field at the ends of the boom. The driver can then drive parallel to the foam.

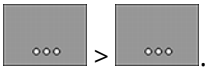
To access the controls:



Use the following function keys to operate the function:

Icon	Meaning
	Switches the left foam marker on and off.
	Switches the right foam marker on and off.

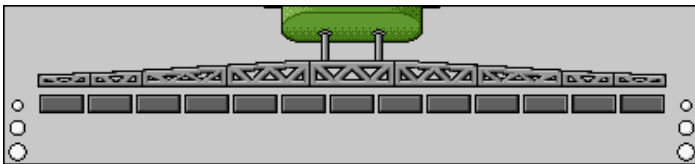

Foam marker activated on both sides of the boom



Operating Additional Functions





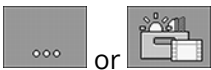













Additional functions are manufacturer-specific functions. They can only be activated or deactivated by pressing a button.







All functions are in the additional screens.

To access the controls:



Icon	Function that can be activated or deactivated
	Working light
	Beacon
	Nozzle lighting

Icon	Function that can be activated or deactivated
	Reversing light
	Mixing hopper lighting
	Ring line circulation system
	Cleaning the ring line circulation system
	Tank cleaning
	Permanent tank internal cleaning
	Spray agent pump
	Stirrer
	Low pressure cleaner
	Lift mixing hopper
	Lower mixing hopper
	High pressure cleaner
	Empty fresh water tank
	Fill fresh water tank
	Compressed air flushing
	Filter rinsing
	Left foam marker
	Right foam marker

Icon	Function that can be activated or deactivated
	Four hydraulic functions that can be freely connected
	Drop size increase for AIRTEC
	Drop size decrease for AIRTEC
	Lower the transport hooks for securing the boom
	Raise the support leg
	Lower the support leg
	Spot spraying

Regulating Drop Size with AIRTEC

AIRTEC is a system for regulating the drop size on field sprayers. It adds compressed air to the spray mixture directly in the nozzle at a ratio calculated by the ECU.



Minimum equipment of the field sprayer:















- Nozzles with air support
- Air compressor: on the field sprayer or on the tractor.

The ECU regulates the air pressure such that the drop size always remains constant. Even when the spray pressure changes.

NOTE - For the system to be able to work optimally at the beginning of the field, the speed should be the same when switching off the sprayer at the end of the field as well as when switching on at the beginning of the field, and should correspond as closely as possible to the normal spraying speed.

Airtec Icons

Icon	Meaning
	Current air pressure.
	System is increasing the air pressure.

Icon	Meaning
	System is reducing the air pressure.
	Air compressor is off.
	Air compressor is on.
	Manual mode is activated. The number indicates the drop size.
	Drop size (automatic mode activated).
	Switches between manual and automatic mode.
	Starts and stops the air compressor mounted on the field sprayer. (optional)
	Larger drops.
	Smaller drops.
	Increases the pressure.
	Reduces the pressure.
	Calls up the screen with settings.
	Smaller nozzle.
	Bigger nozzle.

Switching the Air Compressor On and Off

The system works with two types of compressors:

- Compressor on the sprayer - is switched on and off on the ECU using a function key.
- Compressor on the tractor

CAUTION – Liquid in the compressed air system

Damage to the compressed air system

- Only switch the air compressor off when the AIRTEC nozzles are not installed. If AIRTEC nozzles are installed, the air compressor must be activated.

To switch the air compressor on:

1.  - Press.

This icon appears on the work screen:



Air compressor will be switched on.

To switch the air compressor off:

1.  - Press.

This icon appears on the work screen:



Air compressor will be switched off.

AIRTEC in Automatic Mode

In automatic mode, select the drop size that you want to achieve. The air pressure is adjusted so that this drop size is reached.

Before you begin, make sure:

- AIRTEC nozzles are installed.
- AIRTEC is configured.
- Air compressor is on.

1.  - Setting the drop size.

The set drop size appears on the work screen:



AIRTEC in Manual Mode

In manual mode, you control the air pressure manually. The air pressure changes the drop size.

1.  - Set the air pressure.

The target air pressure appears beside the icon:





As long as the compressor is regulating the air pressure, + or - appears beside this icon:

Using ISB Short-Cut Button

If you are using your terminal with an ISB short-cut button, you can use it to directly terminate various functions of the implement, depending on the configuration.

The following functions can be configured:

- **Sprayer:** All of the spraying functions are stopped.
- **TRAIL-Control:** All TRAIL-Control functions are stopped.
- **DISTANCE-Control:** All DISTANCE-Control functions are stopped.

Trailed Implement with Dual Axles

Trailed implements with dual axles can be represented on the display:

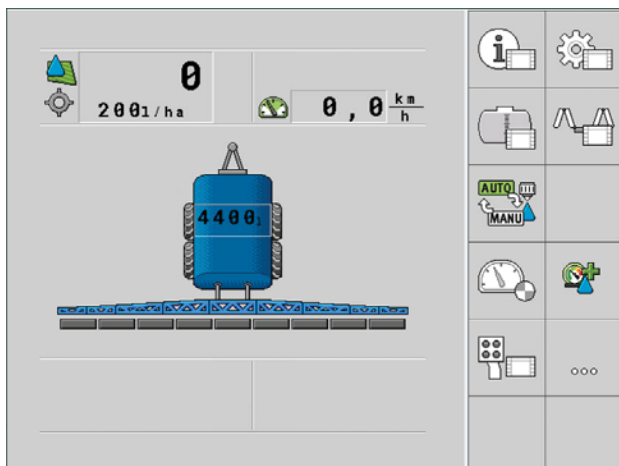

Stirring Control

Added different options and features to control the sprayer stirring phase. Icons and features are directly connected to what's been defined in the sprayer configuration with (Field-IQ ISOBUS Sprayer configurator).

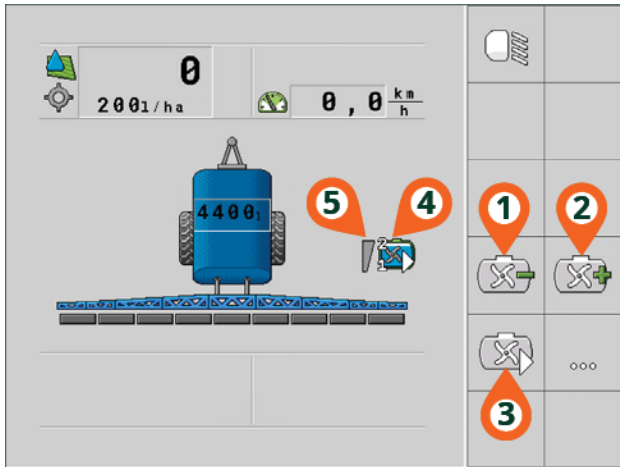

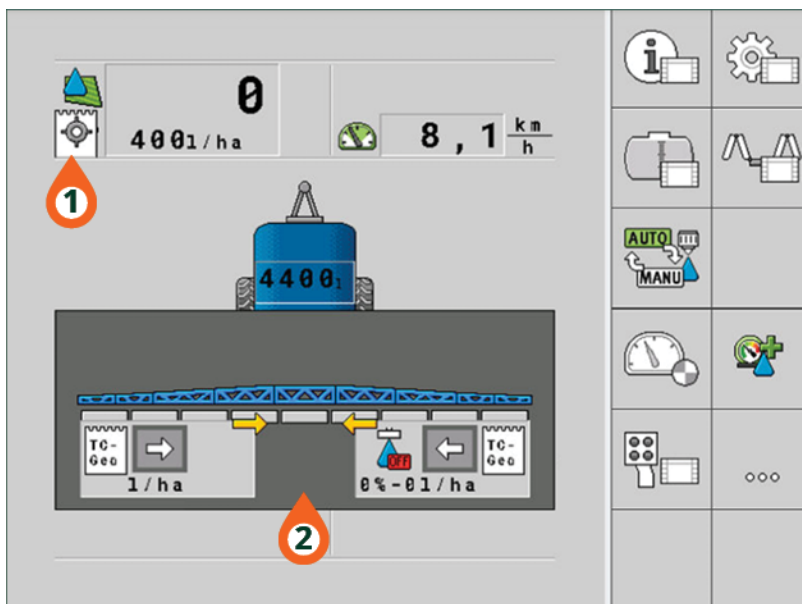

Item	Icon	Description
1		Decrease stirring flow.
2		Increase stirring flow.
3		Toggle: pause, stage
4	 	Status: <ul style="list-style-type: none"> • Stirring paused • Stirring stage 1 • Stirring both stage 1 plus stage 2
5		Stirring status bar graph Stirring icons include a specific bar graph in order to determine the status of the stirring valve, if the valve includes a proper integrated sensor which can provide a signal to the ECU.

TC-GEO Management



Item	Description
1	Enable TC-GEO pop-up window toggle
2	<ul style="list-style-type: none"> • Disable/enable rate input • Disable/enable section control

Icon	Meaning
	TC-GEO ACTIVE (Rate applied aligned with TC-GEO input)
	TC-GEO ACTIVE (Applied rate cannot reach TC-GEO input)
	TC-GEO INACTIVE (Rate applied NOT from TC-GEO input)
	Disable Rate input from TC-GEO (Status: ENABLED)
	Enable Rate input from TC-GEO (Status: DISABLED)

Icon	Meaning
	<p>Disable section control with 0% rate from TC-GEO (Status: ENABLED)</p>
	<p>Enable section control with 0% rate from TC-GEO (Status: DISABLED)</p>

Configuring the ECU

- Entering Sprayer Parameters
- Configuring the Control Units
- Configure ISO Settings
- Color Customization
- Calibrating the Flow Meter
- Calibrating an Analog Pressure Sensor
- Selecting and Configuring the Speed Sensor
- Configuring the Nozzles - for sprayers with pressure sensor regulation
- Extremity Nozzles
- Rotational Speed Configuration
- Band Spraying Configuration
- Spot Spraying Configuration
- Configuring AIRTEC
- Configuring the Integrated TANK-Control III
- Configuring the Units
- Entering the Password
- Entering the Sprayer Geometry
- Configuring the Raven Direct Injection
- Calibrating the Sensors for Reproducing the Boom Slope
- Field Sprayer with Two Circulations and ECUs
- Activating Licenses
- Assigning the Joystick Buttons

Entering Sprayer Parameters

Enter the parameters in the following cases:

- Prior to initial start-up.
- When the sprayer parameters change.

To change the value of a parameter:

1. Switch to the "PARAMETERS" screen:



The "Parameters" screen appears.

A small rectangular box with a value appears under each parameter.

2. Select this box to change a parameter.



Screen for data input or keyboard appears.

3. Enter desired value.

The new value appears on the "Parameters" screen.

The parameters appearing on your screen depend on the type and configuration of your sprayer.

Parameter	Description
Nozzle	<p>Colour of the activated nozzles.</p> <p>The colours are specified by the ISO standard. The nozzles can also be calibrated.</p> <p>This parameter only appears on systems that do not have a flow meter. With these systems, a pressure sensor for determining the application rate is used instead.</p>
Target Rate	<p>The quantity entered as the target rate will be applied when the sprayer is working in automatic mode.</p> <p>You can configure up to three different target rates, between which you can switch on the work screen.</p>
Jump Start Time	<p>With this parameter, you can simulate the speed after switching on the sprayer (at least one section will be switched on).</p> <p>The set simulated speed is then used for the entered "Jump start" duration before switching to the regular speed.</p> <p>If the simulated speed is 0, this parameter is deactivated.</p> <p>With the "Jump start" duration, the application rate is increased when starting off to prevent insufficient application rates at the beginning of the field.</p>
Working Width	<p>Working width of sprayer.</p>
Wheel Impulses	<p>Number of impulses the wheel sensor sends to the ECU on a 100m distance. Used to calculate the speed.</p> <p>The number is determined by the wheel sensor calibration.</p>
Circulation Type	<p>"Non constant pressure" - For manifolds without the "Constant pressure" function.</p> <p>"Constant pressure" - For manifolds with the "Constant pressure" function.</p>

Parameter	Description
Minimum Pressure	<p>This setting defines the minimum pressure up to which the spraying pressure is optimal.</p> <ul style="list-style-type: none"> • If the spraying pressure drops below the defined pressure, an alarm is issued. • If no pressure sensor is installed on your sprayer, you must enter "0" as the value. • If the "Pressure limit" parameter is configured on your sprayer, the minimum pressure set there will not be undercut while spraying.
Maximum Pressure	<p>This setting defines the maximum pressure up to which the spraying pressure is optimal.</p> <ul style="list-style-type: none"> • If the spraying pressure increase beyond the defined pressure, an alarm is issued. • If no pressure sensor is installed on your sprayer, you must enter "0" as the value. • If the "Pressure limit" parameter is configured on your sprayer, the maximum pressure set there will not be exceeded while spraying.
Sprayer Off Below	<p>(Minimum working speed)</p> <p>If the sprayer speed drops below the minimum working speed, the following happens:</p> <ul style="list-style-type: none"> • Application will be switched off automatically. • The work screen displays the icon  <p>When the value is set to 0, this function is deactivated.</p>
Regulation off Below	<p>If the sprayer falls below this speed, the following happens:</p> <ul style="list-style-type: none"> • The flow will no longer be regulated and the flow remains unchanged. • Manual mode will be activated. • The work screen displays the icon  <p>When the value is set to 0, this function is deactivated.</p> <p>This parameter must be higher or the same as the "Sprayer off below" parameter.</p>
Tank Size	Size of the tank for the spray liquid.
Tank Level Alarm	When the tank content falls below this value, an alarm message appears on the screen.
Impulses Main Flow	<p>Number of impulses the flow meter sends to the ECU per one liter of liquid. Used to calculate the application rate.</p> <p>The number is determined by the flow meter calibration.</p>
Stirring off Below	<p>With this parameter, you can set the fill level below which the stirrer should be switched off.</p> <p>The implement manufacturer (not the user!) can also define whether the stirrer should be switched on automatically when the ECU is started.</p>

Parameter	Description
Regulation Factor	<p>In Automatic mode, the spray pressure of the nozzles is adapted to the current speed of the sprayer. The adjustment should ensure that the volume of spray liquid that is applied is exactly what you defined in the target rate. The regulation factor plays a decisive role here.</p> <p>The regulation factor adjusts the reaction speed of the regulation:</p> <ul style="list-style-type: none"> • The higher the regulation factor, the faster the spray pressure is adjusted. • The lower the regulation factor, the more slowly the spray pressure is adjusted. <p>When setting the regulation factor, you can pay attention to the following:</p> <ul style="list-style-type: none"> • If, during movement at constant speed, the current application volume jumps around the target rate, you need to reduce the regulation factor. • If, when speed is changing, the application volume does not adjust to the rate quickly enough, you need to increase the regulation factor. <p>For the regulation factor, you can also define permissible deviations.</p>  - Switch to the "Spray regulation" screen. There, you will find the "Large deviation" and "Smallest deviation" parameters that you can configure for the regulation factor. <p>The "Large deviation" controls the regulation factor if there is a large deviation between the target and the current value and the "Smallest deviation" controls the regulation factor if there is a small deviation between the target and actual value.</p>
Maximum Wind Speed	<p>Wind sensor must be installed.</p> <p>If the maximum wind speed is exceeded, an alarm will be triggered.</p>
Extremity Nozzles Set	<p>With this parameter you can specify which extremity nozzles are mounted on the boom.</p>
Section Control	<p>Manner in which the sections are switched on and off.</p> <p>"Sequential mode" is intended for normal spraying work. It is also suitable for spraying on wedge-shaped areas and strips that are narrower than the working width of the sprayer.</p>
Filling Mode	<p>With this parameter, you can define whether you want to use TANK-Control for filling.</p> <ul style="list-style-type: none"> • "Manual" - For sprayers without TANK-Control. • "TANK-Control" - Activates TANK-Control.
Boost Pressure Target Rate	<p>Pressure setpoint when a booster pump is being used.</p>

Configuring the Control Units

The joystick and S-Box control units are configured on a screen.

1. Switch to the "Parameters" screen:



The "AUX controls" screen appears.

2. Configure parameter.

Parameter	Description
Joystick	<p>"Without joystick" - A joystick is not connected. All functions will be controlled using the terminal or an PTx S-Box.</p> <p>"ME joystick" - PTx joystick is being used.</p> <p>"Ignore ME joystick" - The joystick should be ignored. Setting for the auxiliary ECU for systems with two ECUs.</p> <p>"ME joystick: only on/off" - Setting for the auxiliary ECU, if on/off (section main switch) is deactivated on the S-Box.</p>
ME S-Box	<p>"Without ME S-Box" - An S-Box is not connected.</p> <p>"ME S-Box" - Default setting when the S-Box is connected.</p> <p>"Ignore ME S-Box" - For systems with two ECUs, this is the setting for the first ECU. The signals from the PTx S-Box are rejected because this ECU should be operated with the joystick.</p> <p>"ME S-Box without On/Off" - Setting for the second ECU.</p>
Joystick Assistant	<p><input type="checkbox"/> - Preview mode deactivated.</p> <p><input checked="" type="checkbox"/> - Preview mode activated Beside this, you can set the display time for the button assignment.</p>

Configure ISO Settings

Viewing the AEF certification

You can see which ISOBUS functionalities are certified according to the AEF standard.

1. Switch to the "ISO 11783" screen:

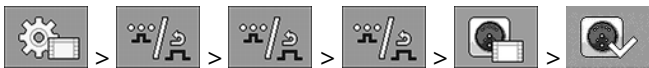

The "ISO 11783" screen appears, and the certified ISOBUS functionalities will be shown.

Configuring the Communication with the Terminal (Condensed Work State)

The ECU allows you to configure the compatibility with various ISOBUS terminals. This is necessary, for example, when the ISOBUS standard changes with time, but a terminal cannot be updated. This section describes the parameters required for this.

Before you begin, make sure you have entered the user and service password.

1. Switch to the "ISO 11783" screen:

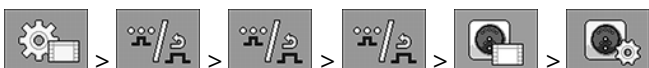

The "ISO 11783" screen appears.

2. Configure parameter.

Parameter	Description
No. 'ECU Number'	If a system with multiple ECUs is used, each ECU must be assigned with a different number.
AEF compliant	This parameter defines whether the ECU should work in compliance with AEF.
SECTION-Control	For automatic section control to work on as many terminals as possible, regardless of the manufacturer, you can define the communication with several parameters.
Condensed Work State	<p>"Condensed Work State" – value for:</p> <ul style="list-style-type: none"> • Systems with EDS individual nozzle switching. • Systems that work with the latest generation of tractor terminals. <p>"No Cond. Work State" – value for all other cases.</p>
DDI	<ul style="list-style-type: none"> • "DDI 141 – [161;176]" – old ISO 11783 standard • "DDI 289 – [290;305]" – new ISO 11783 standard. Tractor terminals that fulfill the most recent ISO standards ONLY work with the DDI 289. For the functioning of SECTION-Control, it might be necessary to convert the ECU to DDI 289. <p>PTx Trimble terminals support all of the listed standards.</p>
Second Connector	With this parameter, you can define whether your implement is equipped with a second connector.

Rearranging the Function Icons





You can rearrange the function icons as needed on the individual screens.

Before you begin, make sure you have entered the user and service password.

1. Switch to the "ISO 11783" screen:



The "Softkeys" screen appears.

2.  /  - Select the menu groups for which you want to rearrange the function icons.
3. Select the screen from which you want to remove a function icon.
4.  - Select the function icon that you want to delete.
5.  - On the same screen or on a different screen, choose the new position for the function icon.
6. Repeat the procedure for other function icons. Alternatively, you can also restore the factory settings:



7.  - Finish the rearrangement.

Selecting the Terminal

If you are using more than one terminal, you can select which one should be used for the ECU.

You can select the terminal either using the VT number or the ISO name.

Selecting the Terminal Using the VT Number

Before you begin, make sure you have entered the user and service password.

1. Switch to the "MULTI-VT screen:

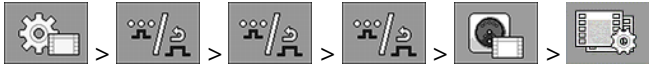

The "MULTI-VT" screen appears.

2. Select "Selection via VT number".
3. Set the desired VT number.
4. For the "Waiting Time" parameter, set the desired time that the ECU should wait after starting before it establishes a connection to a different terminal.

5.  - Confirm.

When starting, the terminal with the set VT number will now always be started first.

Selecting the Terminal Using the ISO Name

Before you begin, make sure you have entered the user and service password.

1. Switch to the "MULTI-VT screen:

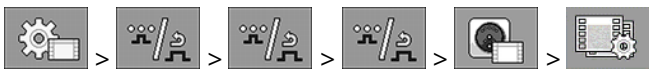

The "MULTI-VT" screen appears.

2. Select "Selection via ISO name".

3.  - Display system information for the terminal.

4. Select the desired standard terminal.

5. For the "Waiting Time" parameter, set the desired time that the ECU should wait after starting before it establishes a connection to a different terminal.

6.  - Confirm.

7. When starting, the terminal with the set ISO name will now always be started first.

Color Customization

Using the Field-IQ ISOBUS Configurator, you can adjust the color of the sprayer's:

- Boom
- Chassis
- Tank

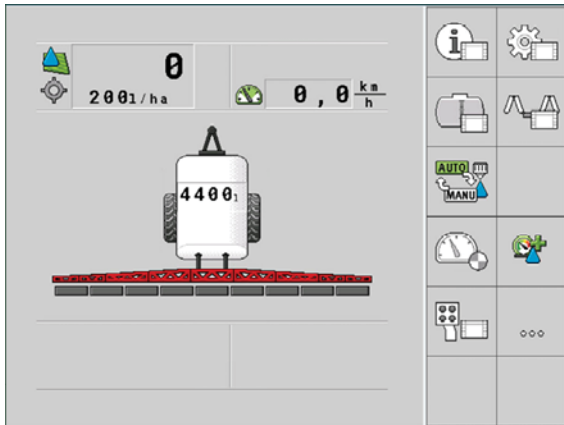

NOTE – Color customization is available *only* if it is enabled via Field-IQ ISOBUS Configurator.

Calibrating the Flow Meter

When should you calibrate?

Because the number of impulses per liter can change during the lifespan of a flow meter, calibration must be carried out in the following cases:

- Prior to initial start-up.
- At the start of each season.
- When you detect deviations between the quantity actually sprayed and the quantity displayed.
- When you have replaced or repaired the flow meter.

Methods

There are two ways you can calibrate the flow meter:

- The tank method – it is time-consuming, but precise.
- The nozzle method – it is not as precise as the tank method, but is less time-consuming.

CAUTION – Imprecise calibration

If the calibration is imprecise, the calculations will be very inaccurate and the application imprecise.

- Calibrate the flow meter very precisely.

Calibrating the Flow Meter with the Tank Method

With the tank method, a large quantity of water will be applied from the tank over a specific time.

The flow meter measures the impulses during this time.

After the application, you must enter the quantity of water that has been applied.

The computer calculates the number of impulses per liter.

DANGER! SPRAY LIQUID OR SPRAY LIQUID RESIDUES

DANGER OF POISONING OR CHEMICAL BURNING

- **CLEAN THE SPRAY LIQUID TANK THOROUGHLY PRIOR TO CALIBRATION. THE SPRAYER MUST BE FREE OF SPRAY LIQUIDS OR SPRAY LIQUID RESIDUES.**
- **USE ONLY CLEAR WATER DURING CALIBRATION.**
- **WEAR REQUIRED PROTECTIVE EQUIPMENT.**



Before you begin, make sure:

- All sections are selected.
- Manual mode is activated.



(the  icon appears in the “Spray data” area of the work screen).

- The tank is filled with clear water. For this, you need several hundred liters of clear water.
- You have the option of weighing the entire trailer or measuring the volume of water applied with another method.
- Pump is switched on.

1. Ensure that all prerequisites have been fulfilled.
2. Weigh the tank.
3. Switch to the “CALIBRATION” screen:



The following screen appears:

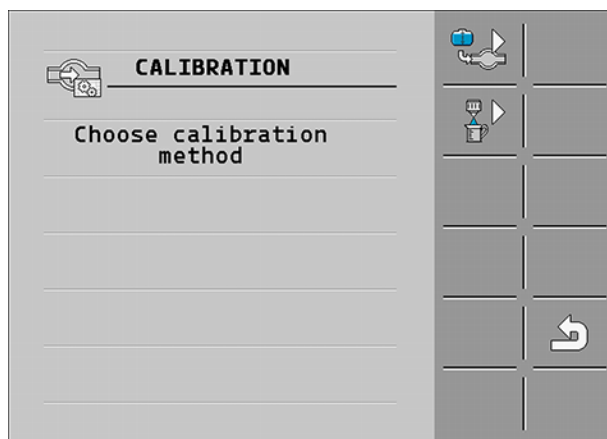

4.  - Select the tank method.

The following screen appears:

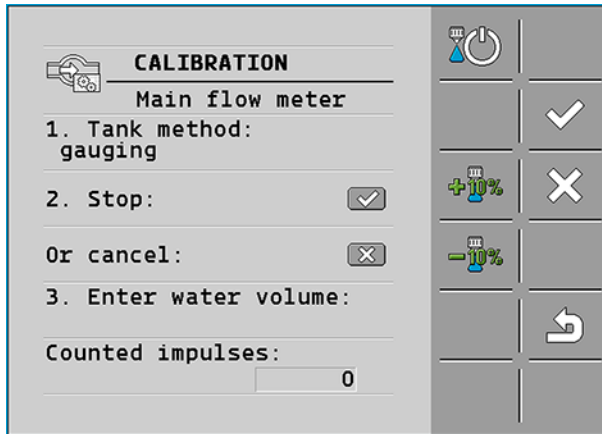

5.  - Start application

During application, the number of impulses will be counted on the "CALIBRATION – Main flow meter" screen.

6. Apply a few hundred litres. Do not fully empty the tank. This prevents air bubbles from forming and distorting the results.

7.  - Stop application.

The application will be stopped.

No impulses are counted on the display.

8.  - Stop calibration.

Weigh the tank.

Enter the applied quantity in litres on the "Enter water volume" line.

9.  - Exit the screen.

You have calibrated the flow meter with the tank method.

Calibrating the Flow Meter with the Nozzle Method

When calibrating the flow meter using the nozzle method, you determine the average quantity of the liquid applied through a nozzle in a specific time.

When calibrating using this method, you must apply clean water over the entire working width and measure the applied quantity on different nozzles using a measuring cup.

The flow meter measures the impulses during this time.

When you have finished the application, you must enter how much water was applied on average by one nozzle in one minute.

The computer calculates the number of impulses per liter.

DANGER! SPRAY LIQUID OR SPRAY LIQUID RESIDUES

DANGER OF POISONING OR CHEMICAL BURNING

- **CLEAN THE SPRAY LIQUID TANK THOROUGHLY PRIOR TO CALIBRATION. THE SPRAYER MUST BE FREE OF SPRAY LIQUIDS OR SPRAY LIQUID RESIDUES.**
- **USE ONLY CLEAR WATER DURING CALIBRATION.**
- **WEAR REQUIRED PROTECTIVE EQUIPMENT.**



Before you begin, make sure:

- Manual mode is activated.



(The  icon appears in the “Spray data” area of the work screen.)

- You have prepared a measuring cup to measure the applied quantity.
- You have prepared a stopwatch to be able to count one minute precisely.
- All of the sections are preselected, and the sprayer can apply over the entire working width.
- The tank is filled with clear water.
- The set working width is correct.
- The number of nozzles per section and the number of sections is entered correctly.

1. Ensure that all prerequisites have been fulfilled.
2. Switch to the “CALIBRATION” screen:



The following screen appears:

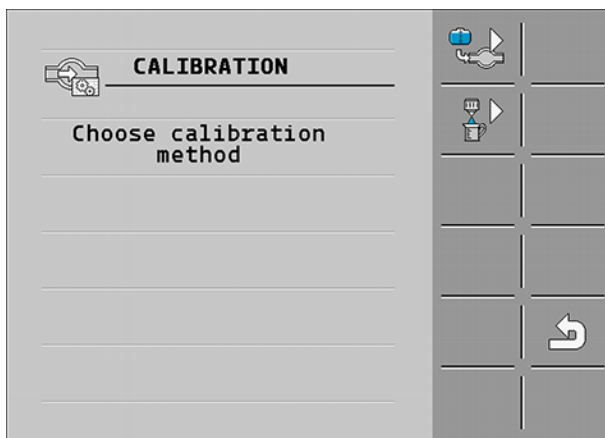

3.  - Select the nozzle method.

The following screen appears:

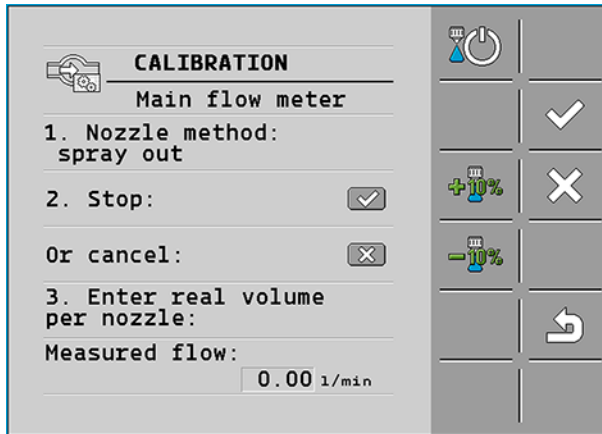

The current flow appears on the “Measured flow” line.

4.  - Start application
5. Go to one of the nozzles and carefully collect the water sprayed for 60 seconds by using the prepared measuring cup.
6. Write down the applied water volume.
7. Repeat the last two steps on several nozzles.
8. Calculate and write down an average of several measurements.

9.  - Stop application.

The application will be stopped.

10.  - Stop calibration.

On the "3. Enter real volume per nozzle" line, an input box appears.

Enter the average applied volume in litres in this box.

11.  - Exit the screen.

The value of the “Impulses main flow” parameter will be updated.

You have calibrated the flow meter with the nozzle method.

Manually Entering the Number of Impulses per Liter for the Flow Meter

If you know the precise number of impulses per liter for the flow meter, you can enter this value manually.

1. Switch to the “FLOW METER” screen:



2. Enter number of impulses per liter on the “Impulses main flow” line.

Combining the Flow Meter with the Pressure Sensor

If a pressure sensor is installed on the sprayer, you can combine the regulation via the flow meter and the pressure sensor. This enables more stable regulation even at low flow rates.

1. Switch to the "FLOW METER" screen:



2. Activate the "Combined flow/pressure regulation" parameter.
3. Configure parameter.

Parameter	Description
Flow Tolerance	Enter a percent value at which the system should switch to pressure regulation. If the difference between the calculated flow from the pressure sensor and the measured flow from the flow meter is greater than the entered value, the system switches to pressure control.
Threshold Flow	Enter the minimum flow that must be reached for flow regulation to be used. If the flow rate is below the entered value, the system switches to pressure control.

Calibrating an Analog Pressure Sensor

If an analogue pressure sensor is installed on the sprayer, you have to calibrate it before initial use. Calibration determines how high the respective current is when there is no pressure and at maximum pressure.

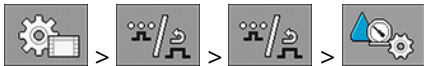

Before you begin, make sure you have a reference sensor at hand to measure the pressure.

1. Switch to the "PRESSURE MEASUREMENT" screen.



The "PRESSURE MEASUREMENT" screen appears.

The currently measured pressure appears.

2.  - Open the "CALIBRATION" screen.
3. Use the reference sensor to verify the pressure of 0 bar.
4.  - Open the calibration for the zero value.
5. Switch off the implement to put it in a depressurized state.
6.  - Start the calibration for the zero value.

The current is being measured.

7. Using the pressure regulator, set the maximum system pressure and measure it with an external reference pressure sensor.
8. Enter the maximum pressure of the flow meter in the "Maximum pressure" parameter.

9.  - Open the calibration for the maximum value.

10.  - Start the calibration for the maximum value.

The current is being measured.

11. You have completed the calibration of the analogue pressure sensor.

Selecting and Configuring the Speed Sensor

You must enter the source from which the ECU shall obtain the current speed.

The configuration procedure can differ depending on the speed source.

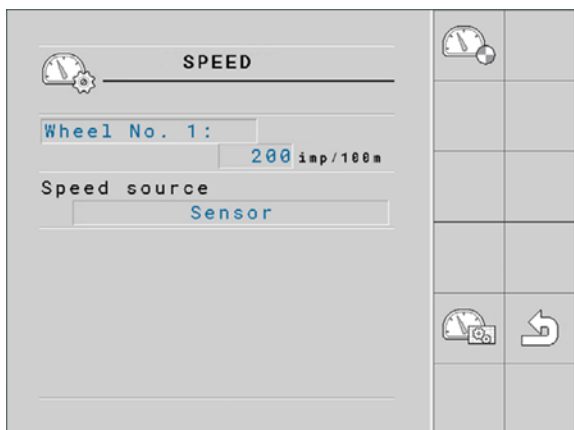

Selecting the Speed Source

Supported speed sources:

- **Sensor** – Sensors that are installed on the implement and connected to the ECU:
 - Examples: Wheel sensor, radar sensor, impulse-transmitting GPS speed sensor
 - Configuration: Configure the number of impulses per 100 meters.
- **CAN Ground Speed** - Ground speed provided by tractor via ISOBUS line.
 - Example: Radar sensor
- **CAN Wheel Speed** - Tractor wheel speed speed is provided via ISOBUS line.
 - Example: Tractor wheel speed
- **CAN GPS speed** - Speed detected by GNSS system is provided via ISOBUS line.
 - Example: GNSS receiver
- **CAN NMEA Speed** - Speed detected by an unspecified source is provided in NMEA2000 format via CAN line.
 - Examples: Wheel speed, GNSS receiver, signal socket, etc.

NOTE – For all CAN speed inputs: For systems without option of selecting the sensor input, the “Wheel impulses” parameter must be set to **0**.

- **Auto** – Some systems enable automatic detection of the speed source.
 - Mode of operation: If a speed signal is detected on the ISOBUS, this speed will be used as a basis. In the case of signal failure, the ECU will take the impulses from the sensor connected to the ECU as a basis for determining the speed.
 - Configuration: For systems that have two sensor types, it is recommended to calibrate the sensor that is connected to the ECU. In other cases, set the “Wheel Impulses” parameter to 0.

Speed sources highlighted in **orange** means that the speed source is not detected (CAN or ext. input). Speed sources highlighted in gray mean that the speed source is available (CAN or ext. input).

Sensor
CAN Ground speed
CAN Wheel speed
CAN GPS speed
CAN NMEA speed
Auto

Procedure 1

To configure the speed source:

1. On the work screen, press the following keys successively:



The “Speed” screen appears.

2. Configure the “Speed source” parameter.

Procedure 2

If the “Speed source” parameter does not appear on the “Speed” screen, and the speed signal should be received through the ISOBUS, proceed as follows:

NOTE – The speed signal can be received through the ISOBUS.

1. Switch to the “PARAMETERS” screen:



2. Set the “Wheel impulses” parameter to “0”.

Calibrating the Speed Sensor with the 100m Method

When calibrating the speed sensor with the 100m method, you determine the number of impulses received by the speed sensor in a distance of 100m. When you know the amount of impulses, the ECU can calculate the current speed.

If you know the number of impulses for the wheel sensor, you can also enter this number manually. You can enter different pulse values for up to three different wheels.

Before you begin, make sure:

- Wheel sensor, radar sensor or GPS speed sensor is installed on the implement.
 - A distance of 100m has been measured and marked. The distance must correspond to the field conditions. It should therefore lead over a meadow or a field.
 - The tractor with connected implement is ready for a 100m drive and is at the start of the marked distance.
1. Ensure that all prerequisites have been fulfilled.
 2. Switch to the "CALIBRATION – wheel impulses" screen:



3.  - Start calibration.

The following function icons appear:



- Stop calibration.



- Abort calibration.

4. Drive the previously measured 100m distance and stop at the end.

During the drive, the currently determined impulses are displayed.



5.  - Stop calibration.



6.  - Exit the screen.

The number of impulses appears on the "Wheel impulses" line

Configuring the Reverse Driving Sensor

If the trailed implement or the tractor sends a reverse driving signal through the ISOBUS, the ECU can use this signal to adjust its regulating behavior when driving in reverse.

You can find more information in this section: Configuring automatism when driving in reverse

Signal Sources

The following signal sources are possible:

- "None" - The ECU should not expect a reverse driving signal. Even if a reverse driving signal is transmitted through the ISOBUS, the ECU will ignore the signal.
- "ISOBUS" - The reverse driving signal is sent by the tractor or a different ECU through the ISOBUS.
- "Sensor" - A reverse driving sensor is connected to the junction box or cable harness of the ECU.

Procedure

To select the reverse signal source:

1. Switch to the "Speed" screen:



2. Select the box below the "Reverse drive sensor" parameter.

The available signal sources appear. See the description at the beginning of this section.

3. Select the signal source.
4. Restart the ECU.

"Simulated Speed" Function

The simulated speed function is only used during tests and when looking for faults. It simulates the movement of the implement when the implement is at a standstill.

By activating the "Simulated speed" function, it is possible for customer service employees to check the correct functioning of a sensor.

By default, the value is set at **0 km/h** and the function is switched **off**.

After restarting the computer, the function is always deactivated.

The most recently set value is saved and used for the next activation.

1. Switch to the "Speed" screen:



2.  - Activate the simulated speed. By pressing again you can deactivate the function.

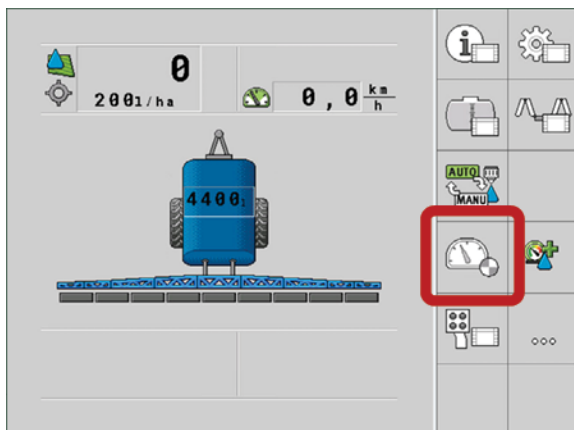

3. The "Simulated speed" line appears.
4. Enter the speed to be simulated on the "Simulated speed" line.

5.  - Exit the screen.
6. The set speed and the flashing  icon appears on the work screen.

Configuring Sections

Entering the Number of Nozzles per Section

You must enter the number of nozzles installed on each section.

When to enter?

- Prior to initial start-up.
- If the number of nozzles in a section changes.

Procedure

1. Switch to the “Boom” screen:



The “Boom” screen appears.

Here, you can see the set working width, the number of sections and the number of nozzles. The two last values may not be changed.

2.  - Press.

The “NUMB. OF NOZZLES” screen appears.

3. Here, you can enter the number of nozzles for each section. Multiple nozzle holders count as one nozzle in this case.

With each change, the number of nozzles changes on the “BOOM” screen.

Switching Sections Off Permanently

You can permanently switch off any section. This is useful, for example, if the tramlines on the field are designed for a smaller field sprayer than yours.

Switching off the outer sections has the following effects:

- With TRACK-Leader: The newly calculated working width will not be taken into account for the calculation of the headland width.
- With SECTION-Control: After switching off the outer sections, you will need to change the “Line spacing” parameter so that the distance between the guidance lines matches the actual working width. You cannot change the “Working width” parameter.
- The actual working width changes. However, as the sprayer has not changed:
 - Do **not** change the “Working width” parameter.
 - Do **not** change the sprayer geometry.

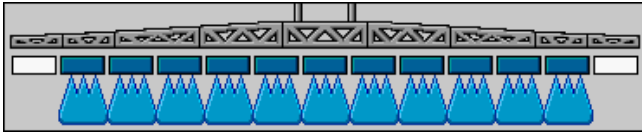

Permanently switched off sections are marked in white on the work screen

1. Switch to the “Boom” screen:



The “Boom” screen appears.

2.  - Press.

The “Sections” screen appears.

For each section, you can see one of the following icons:



- Section activated



- Section deactivated.

3. For each section, you can select and change this icon.

Permanently Switching Off a Section using a Sensor

If a sensor for monitoring the unfolding of boom sections is installed on the boom, sections can be automatically permanently switched off.

This enables the use of a field sprayer with multiple working widths without having to change the configuration each time.

System Delay When Switching the Sections

For SECTION-Control to be able to open and close the section valves precisely, you must determine how many milliseconds are required for the liquid to travel from the valve to the nozzle. Afterwards, the ECU will switch the valves earlier or later accordingly.

Before you begin, make sure you are using the automatic SECTION-Control.

1. Read the operating instructions for the TRACK-Leader app to find out how to determine the delay times.
2. Determine the delay times.
3. Open the ECU application.
4. On the work screen, press:



The “SECTION-Control” screen appears:

5. Enter the determined delay times under “Delay on start” and “Delay on stop”.

Parameter	Description
Delay on Start	Time that elapses between the opening of a section valve and the emergence of liquid out of the nozzles. Rule of thumb: <ul style="list-style-type: none"> • If the sprayer switches too late, increase the value of the parameter. • If the sprayer switches too early, decrease the value of the parameter.
Delay on Stop	Time during which the nozzles continue spraying after the valve has been closed. Rule of thumb: <ul style="list-style-type: none"> • If the sprayer switches too late, increase the value of the parameter. • If the sprayer switches too early, decrease the value of the parameter.

Changing the Display of Areas on the Terminal

You can make different settings to change the display of the areas on the terminal, e.g. for the TRACK-Leader application.

1. On the work screen, press:



2. Configure the “Zero target rate areas” parameter. The following configuration options are available to you:

Sections off	Applied on the map	Function
deactivated	---	The sections are not closed when the application rate is 0 l/ha. Everything is recorded in the process.
activated	deactivated	The sections are closed when the application rate is 0 l/ha. Only the applied areas are recorded.
activated	activated	The sections are closed when the application rate is 0 l/ha. Both the applied areas and areas where nothing was applied will be recorded. This is the standard setting when using SECTION-Control.

Configuring the Nozzles - for sprayers with pressure sensor regulation

By configuring the nozzle type, the ECU can calculate the current application rate based on the measured spray pressure.

You only have to configure the nozzles if a pressure sensor is installed on the sprayer.

If no pressure sensor is installed on the sprayer and the application rate is regulated only through the flow rate, then you do not need to configure the nozzles.

Nozzle Assistant

The nozzle assistant serves the following purposes:

- To show how the nozzle type affects the possible application rates and speeds.
- To help with the correct selection of the installed nozzle type.
- To change the target rate.

Function icon	Meaning
	Changes the calculated data

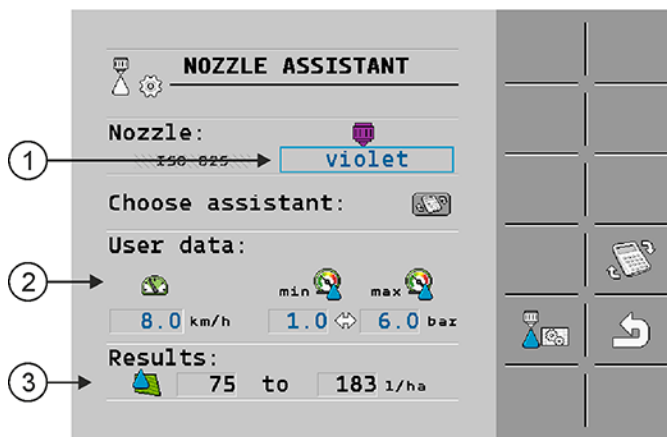

Determination of possible application rates

Item	Meaning
1	Selected nozzle
2	Here, you can enter: <ul style="list-style-type: none"> • The intended working speed • The optimal pressure for the nozzle
3	Here, you can see which application rates are possible with this nozzle at the set working speed.

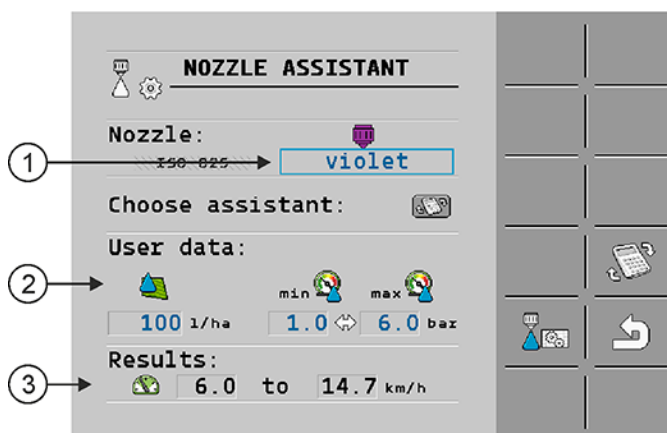



Determination of the fitting nozzles

Item	Meaning
1	Selected nozzle
2	Here, you can enter: <ul style="list-style-type: none"> The intended application rate This is adopted directly from the "Rate" parameter. The optimal pressure for the nozzle.
3	Here, you can see the speed at which this application rate can be reached.

To calculate the application rate that can be reached with a nozzle at a given pressure:

1. Switch to the "Nozzle assistant" screen:



2.  - Press for the  speed icon to appear in the "User data" area.
3. Select the box with the nozzle color to select a nozzle.

The list contains all standard nozzles and four positions for the configuration of custom nozzles.

4. Enter the intended working speed in the  box.



5. In the  area, set the optimal pressure range that enables the intended drop size with the selected nozzle. This value can be found on the nozzle data sheet.



NOTE - The pressure range set here will not be adopted for the application. During operation, you must ensure for yourself that the sprayer is working in the intended pressure range.

In the "Results" area, the possible application rates appear.

If the calculated application rate is too high or too low:

- Change the working speed.
- Install different nozzles. Perform the calculation for the new nozzle color.

The calculation can be performed based on the intended application rate:

1.  - Press for the  icon to appear in the "User data" area.
2. Enter the intended application rate in the  field.
3. Enter the pressure range for the nozzle color.
4. In the "Results" area, you can see the speed at which the application rate can be achieved.

Calibrate the Nozzles

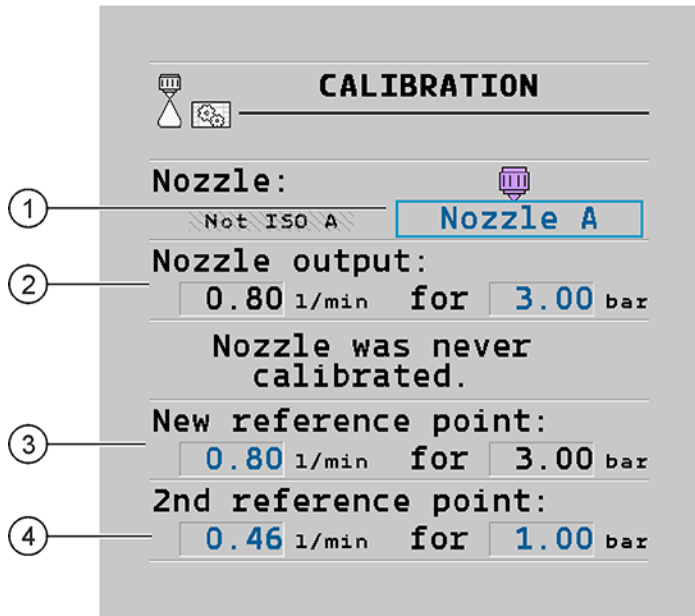

“Calibration” screen

Item	Meaning	Item	Meaning
1	Selected nozzle	3	Nozzle output at 3 bar - Result of the calibration
2	Current nozzle output. When you change the pressure, the newly calculated nozzle output appears.	4	For non-standard nozzles, the calibration must be repeated at a different pressure. This pressure should be about as high as the intended working pressure.

DANGER! SPRAY LIQUID OR SPRAY LIQUID RESIDUES

DANGER OF POISONING OR CHEMICAL BURNING

- **CLEAN THE SPRAY LIQUID TANK THOROUGHLY PRIOR TO CALIBRATION. THE SPRAYER MUST BE FREE OF SPRAY LIQUIDS OR SPRAY LIQUID RESIDUES.**
- **USE ONLY CLEAR WATER DURING CALIBRATION.**
- **WEAR REQUIRED PROTECTIVE EQUIPMENT.**



Before you begin to calibrate a standard nozzle, make sure:

- The tank is filled with clear water.
- There are no spray liquid residues in the tank or the pipelines.

1. - On the work screen, switch the application mode to manual.
2. - Start application
3. and - Set the spray pressure to 3 bar.

4. Using a measuring cup, collect the water from several nozzles for one minute each.
5. Calculate average application rate.

6.  - Stop application.

7.  - Activate automatic mode.

8. Switch to the "Calibration" screen:



9. On the "Nozzle" line – select nozzle for calibration. Standard nozzles are referred to by their colors.
10. In the box below the "New reference point" line, enter the calculated average quantity in l/min.
11. For undefined nozzles, you must also enter the nozzle's minimum output in the "2nd reference point" parameter. To do so, you must repeat the procedure at a different pressure.

You have calibrated the selected nozzle.

Extremity Nozzles

Extremity nozzles are nozzles with a different spray pattern from the other nozzles on the boom. They can either restrict the spray width, in which case they are used for spraying field edges (corner nozzles), or increase the spray width of a section (wide area nozzles).

Before using extremity nozzles, note the following:

- Wide area nozzles or corner nozzles can be installed as extremity nozzles. You can choose the icon used to represent the extremity nozzle on the work screen.
- Extremity nozzles can be installed at the outer end of any section.
- The width of the spray cone is irrelevant for the ISOBUS ECU. It is never detected and is not taken into account in the following calculations:
 - when calculating the working width,
 - when calculating the applied quantity,
 - when calculating the tank content.
- The TRACK-Leader and SECTION-Control applications from PTx Trimble do not take account of the width of the spray cone from the extremity nozzles; they treat them as normal nozzles.. If you are using these applications, you may have to adjust the working width manually.

Configuring the Extremity Nozzles

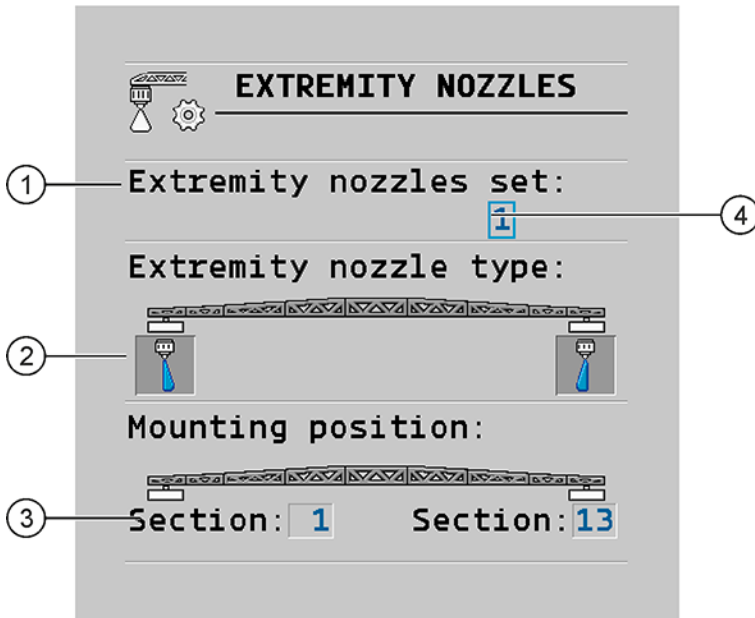

Screen for configuring the extremity nozzles

Item	Meaning	Item	Meaning
1	“Extremity nozzles set” parameter	3	Installation site for the left and right extremity nozzle
2	Extremity nozzles left and right	4	Currently selected extremity nozzle pair

“Extremity Nozzles Set” Parameter

You can define up to three sets of extremity nozzles via the “Extremity nozzles set” parameter. For each set, you can define the installation site and the relevant work screen icon.

Icon	Meaning
	No nozzle
	Corner nozzle
	Wide area nozzle

To configure the extrem. nozzles modes:

1. Call up the screen with the extremity nozzle settings:



The following screen appears:

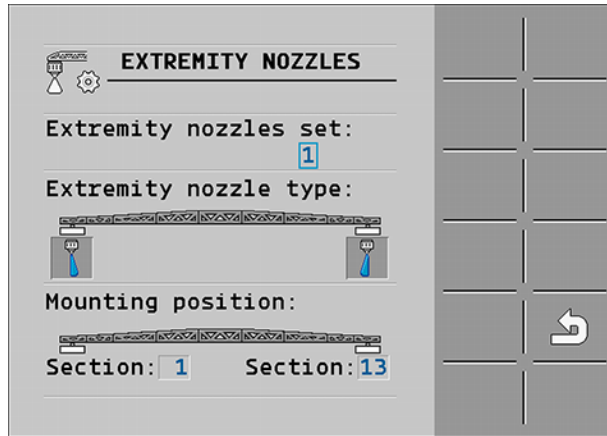

2. On the “Extremity nozzles set” line, enter the set of extremity nozzles for which you want to enter settings. For example “2”:

The saved settings appear on the screen.

3. Select one of the nozzle icons under the boom icon.

4. Select the type of extremity nozzle required.

An alarm message appears. This message informs you that the ECU must be restarted so that the changes can be applied. Do not restart the ECU yet; wait until you have entered all the settings.

5. In the “Installation site” area, enter the section on which the extremity nozzles are installed.

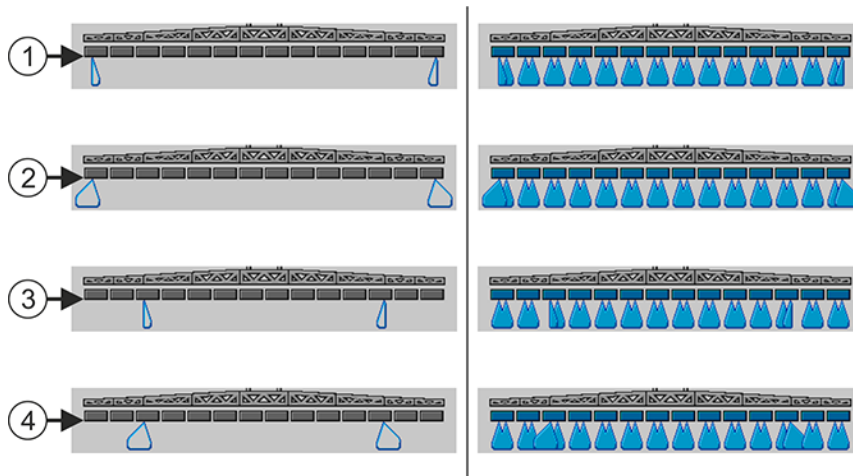

6. Restart the ECU.

Operating the Extremity Nozzles



Extremity nozzles on the work screen: Left: before application; Right: during application.

Item	Meaning	Item	Meaning
1	Corner nozzles on sections 1 and 14	3	Corner nozzles on sections 3 and 12
2	Wide area nozzles on sections 1 and 14	4	Wide area nozzles on sections 3 and 12

Icon	Meaning
	Activate and deactivate corner nozzles on left and right
	Activate and deactivate wide area nozzles on left and right

To operate the extremity nozzles:

1. Stop application.
2. Change to the additional screens:



Function icons used to operate the extremity nozzles should appear on the screen.

3. Press the function keys for the extremity nozzles to show them on the screen.







Spray cones for the extremity nozzles appear below the boom icon. The icons are only used to show the extremity nozzle positions.

Rotational Speed Configuration

If the rotational speed of the fan or the pump is higher than the maximum permitted rotational speed, an error message appears. This allows drivers to have better control of their work and prevent the fan or the pump from being damaged when the speed is too high.

Different rotational speeds can be configured for the fan or the pump for different types of work. A different icon is shown depending on whether you are configuring a fan or a pump.

The available rotational speeds can be found in the following table:

Icon	Meaning
	Default rotational speed 1
	Default rotational speed 2
	Rotational speed when working on the headlands
	Rotational speed when cleaning
	Rotational speed when filling
	Rotational speed in manual mode

1. Switch to the "RPM control" screen:



2. Enter the rotational speed for the desired types of work.
3. Activate the rotational speed for the desired types of work.



4. - Configure other rotational speed parameters.

Parameter	Description
Acceleration	The percentage acceleration of the rotational speed.
Regulation Factor	The regulation factor adjusts the rotational speed of the fan or the pump: <ul style="list-style-type: none"> • The higher the regulation factor, the faster the rotational speed is adjusted. • The lower the regulation factor, the more slowly the rotational speed is adjusted.
Max. Speed	Maximum rotational speed of the fan or the pump.

Band Spraying Configuration



When you work with band spraying, the target rate can be converted to the area ratio. The worked area is then only a percentage of the area that is covered with the tractor. Only the respective seed bands are still sprayed.

1. Switch to the "PARAMETERS" screen:



The following screen appears:



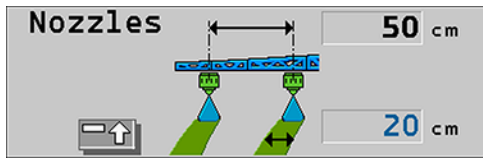

2.  - Activate band spraying mode.
3.  - Call up the configuration for the width of the individual bands.

The following depiction appears:



You will see the set nozzle spacing.

4. Enter the width of the individual bands as shown in the figure.
5.  - Go to the previous screen.
6. You will now see the  - Total area and  - Area for application. The set target rate of 375 l/ha will therefore now be based on an area of 21.33 ha.

Spot Spraying Configuration

Spot spraying is camera-supported spraying where only the desired target surfaces are treated. Spot spraying can only be used in conjunction with the EDS system.

Pressure-based regulation is used for operation. Spot spraying enables correct control of the flow with very rapid nozzle switching.

1. Go to the "Spot Spraying" screen:

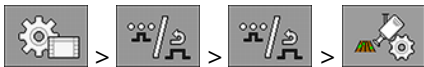

The "Spot Spraying" screen appears.

2. Configure parameter.

Parameter	Description
Resolution	If "Triple" or "Quintuple" is activated, the nozzle is opened as soon as the camera detects a corresponding area.
VT Update Rate	This parameter defines how often display instructions are sent to the terminal. The lower the value, the fewer display instructions are sent. The default value should be set to "5".

Configuring AIRTEC

For the AIRTEC configuration, you only have to select the nozzle number for the mounted nozzle.

CAUTION - Wrong nozzle number

Damage to the plants

Always enter the correct nozzle number.

1. Switch to the "AIRTEC" screen:



2.  - Set the nozzle number.

Configuring the Integrated TANK-Control III

If you are using integrated TANK-Control III, you must perform various configuration steps before initial use. Please note that before configuring the integrated TANK-Control III, the service password must always be entered

Performing the 100 Litre Calibration

The purpose of the 100 litre calibration is:

- To equalize manufacturing tolerances
- To correct changes in accuracy over time.

DANGER!

DANGER OF POISONING FROM SPRAY LIQUID RESIDUES



WHEN CONFIGURING THE TANK, ALWAYS USE CLEAN WATER.

CAUTION -

Inaccurate calibration due to incorrect fill volume.



If the configuration is wrong the fill level cannot be measured accurately. This makes all calculations imprecise.

When calibrating the tank, use a flow meter or a weighbridge.

1.  - Switch to the "Filling" screen.
2.  - Open the calibration.
3. Empty the tank completely.
4. Fill exactly 100 litres into the tank.
5.  - Start a 100-litre calibration.
6. Wait until the process is completed.
7. You have successfully completed the 100-litre calibration.

Performing the Basic Initialization

During basic initialization, a signal is sent once to activate the sensor to ensure that all the connections are OK.

1.  - Switch to the "Filling" screen.
2.  >  - Open the basic initialisation. If you are using more than one tank, select the icon with the desired tank number.

Basic initialization will be performed.

3. Moreover, you can set the sensor sensitivity with the "Filter" parameter. Reduce the value if the sensor reacts too sensitively to water movement.

If the sensitivity is high, the fill levels displayed are updated faster. If the sensitivity is low, the fill levels displayed are updated more slowly.

You have initialized the sensor.

Carrying Out Calibration

The calibration process measures the height of the sensor float. The float height rises as the fill level increases.

During calibration, the tank is filled with water in several steps. The exact position of the float is measured at each step. The computer then knows the position of the float at every fill level.



These values are stored in the memory.

The following types of calibration are available:

- Selecting the pre-set tank
- Automatic calibration
- Manual input

Selecting the Pre-set Tank

If TANK-Control III is installed on a field sprayer model for which the tank characteristics are already stored in the software, you can skip the calibration and simply select the number for the tank.

1.  - Switch to the "Filling" screen.
2.  >  - Open the tank settings.
3. Enter the number of the tank in the "Tank-ID" parameter.

The sensor is calibrated for the corresponding tank.

Planning Calibration

Before you start calibration, you must plan the float heights at which you want to enter the fill level.

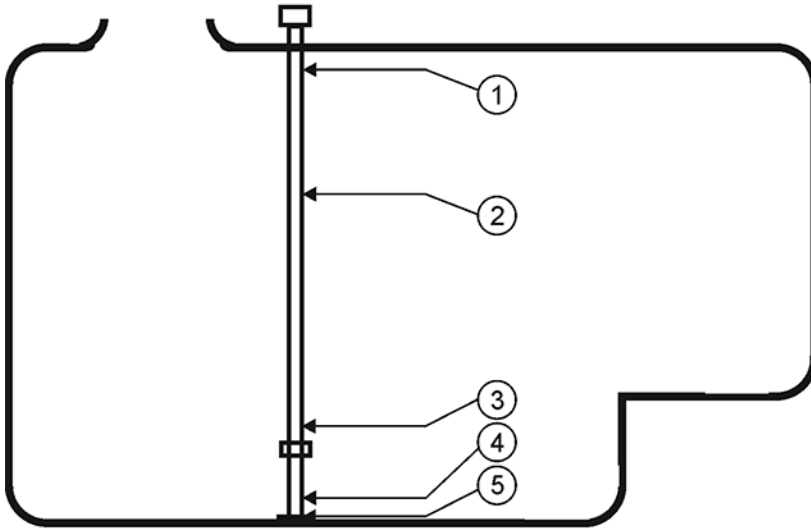

Possible tank shape with calibration points

Item	Description	Item	Description
1	Maximum fill level Calibration point 29	4	Calibration point 01
2	e.g.: Calibration point 21	5	Calibration point 00
3	Calibration point 02		

The table below shows an example of what a planned calibration may look like. The values may be different for every tank. You cannot plan the fill levels at given float heights. The fill levels depend on the size and shape of the tank. In the example, the tank has a capacity of 7200 litres.

Calibration Point	Float Height	Possible Fill Level	Calibration Point	Float Height	Possible Fill Level
0	15 mm	0 l (tank must be empty)	15	750 mm	3000 l
1	25 mm	30 l (first float movement is registered)	16	800 mm	3200 l
2	100 mm	400 l	17	850 mm	3400 l
3	150 mm	600 l	18	900 mm	3600 l
4	200 mm	800 l	19	950 mm	3800 l
5	250 mm	1000 l	20	1000 mm	4000 l
6	300 mm	1200 l	21	1050 mm	4200 l
7	350 mm	1400 l	22	1100 mm	4400 l
8	400 mm	1600 l	23	1200 mm	4800 l
9	450 mm	1800 l	24	1300 mm	5200 l

Calibration Point	Float Height	Possible Fill Level	Calibration Point	Float Height	Possible Fill Level
10	500 mm	2000 l	25	1400 mm	5600 l
11	550 mm	2200 l	26	1500 mm	6000 l
12	600 mm	2400 l	27	1600 mm	6400 l
13	650 mm	2600 l	28	1700 mm	6800 l
14	700 mm	2800 l	29	1800 mm	7200 l (maximum fill level is reached)

To plan the calibration:

1. Check whether your tank has any bulges as they can affect the float height.
2. Note that the tank must be completely empty at calibration point 0. You cannot select the float height yourself.
3. Note that the fill level at which the float registers the first movement must be entered at calibration point 1. You cannot select the float height yourself.
4. Note that the tank must be filled to the maximum fill level at the last calibration point. The maximum fill level is specified by the tank manufacturer. You cannot select the float height yourself.
5. Decide how many calibration points you want to use. You can use a maximum of 30 calibration points.
6. Decide on the float heights at which you want to enter the fill level. If possible, use evenly spaced intervals, e.g. every 50 mm.

You can now start calibration.

Carrying Out Automatic Calibration

DANGER!

**DANGER OF POISONING FROM SPRAY LIQUID RESIDUES
WHEN CONFIGURING THE TANK, ALWAYS USE CLEAN WATER.**

CAUTION -





Inaccurate calibration due to incorrect fill volume.

If the configuration is wrong the fill level cannot be measured accurately. This makes all calculations imprecise.

When calibrating the tank, use a flow meter or a weighbridge.

Before you begin, make sure:

- You have completed the 100-litre calibration.
- You have planned the float heights at which you want to enter the fill level.
- You have pen and paper at hand to write down the fill levels.

1.  - Switch to the "Filling" screen.
2.  >  - Open the tank settings.
3. Enter the value "0" in the "Tank-ID" parameter.
4. Enter the maximum fill level for the tank in the "Tank Max" parameter.
5.  - Open the "Calibration" screen.
6. Empty the tank completely.

In the bottom area of the screen, you can see the current calibration point 0 and the current floater height.

7.  - Start automatic calibration.
8. Fill the tank with water until the sensor registers the first movements.

You have reached calibration point 1.

9. Enter the current fill level of the tank.
10. Write down the current fill level of the tank. You will then have a record of the values so you will not have to repeat the entire calibration process if an error occurs, and can calibrate an identical tank manually in the future.

11.  - Resume the automatic calibration.
12. Fill the tank up to the next planned floater height. The planned level in the example is 100 mm.

A signal tone is issued.

You have reached calibration point 2.

13. Enter the current fill level of the tank. In the example, we assume a fill level of exactly 400 litres.
14. Write down the current fill level of the tank.
15. Repeat the procedure for a maximum of 30 calibration points in total.

16.  - Stop the automatic calibration and save.



You have completed automatic calibration.







Enter Calibration Values Manually

You can input calibration values manually if you have already carried out automatic calibration on an identical tank and know the fill level at each float height.

To save time, you can enter the individual values without filling the tank.



Before you begin, make sure you have calibrated an identical tank and have the individual values to hand.

1.  - Switch to the "Filling" screen.
2.  >  - Open the tank settings.
3. Enter the value "0" in the "Tank-ID" parameter.
4. Enter the maximum fill level for the tank in the "Tank Max" parameter.

5.  - Open the "Calibration" screen.
6.  /  /  /  - Mark the fill level or floater height that you want to change.
7. Enter the desired settings. Use the values from the identical tank.
8. Repeat the procedure for all values that you want to change.
9.  - Finish input and save.

Changing the Number of Sensors

If you are using two tanks on your field sprayer, you can also use TANK-Control III with two sensors.

1.  - Switch to the "Filling" screen.
2.  - Open the tank settings.
3. Enter the value "2" in the "Number of sensors" parameter.

New function icons now appear everywhere where you can switch between the two sensors and tanks.

You can now configure the second tank. Proceed exactly like for the first sensor. You just have to select the sensor you want to configure.

Configuring the Units

You can configure all of the units that are displayed on the terminal. You can select between various metric and imperial units.

1. On the work screen, press:



The "Units" screen appears.

On the screen, you will see which categories and subcategories can be configured.

2. Enter the settings required.
3. You have the option of configuring the parameters "Number of decimals" and "Decimal (fixed)" for each category and subcategory.

All of the displayed values will be converted and displayed in the configured units.

Parameter	Description
Number of Decimals	Enter how many decimal places should be displayed.
Decimal (fixed)	Activate this parameter if the decimal point should not be automatically shifted. The decimal places then also remain even with larger numbers.

Entering the Password

To be able to configure specific functions, you have to first enter a user password and sometimes a service password.

Only make changes in the password-protected area if you have extensive knowledge of the implement and the ECU application.

1. Switch to the "Parameters" screen:

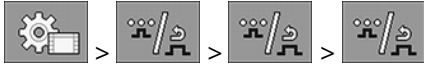

2. Enter the user password.



3. - Press.

4. If necessary, enter the service password.

Now you can configure additional functions.

Entering the Sprayer Geometry

Sprayer geometry is a set of parameters that describe the dimensions of your implement.

Setting the sprayer geometry lets the software know exactly how long and how wide the sprayer is and where the individual sections are located.

Sprayer Geometry Parameters

When setting the sprayer geometry, you must measure the following distances:

- **CRP** – Attachment point, or point from which the measurements are taken. For self-propelled machines, it can be the position of the GPS receiver, and for mounted and trailed sprayers, the mounting or attachment point.
- **DRP** – Pivot point of the sprayer, or point at which there is soil contact.
- **ERP** – Position of the nozzles.

1. Switch to the "Geometry" screen:

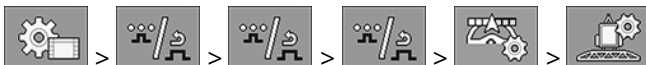

The following screen appears:

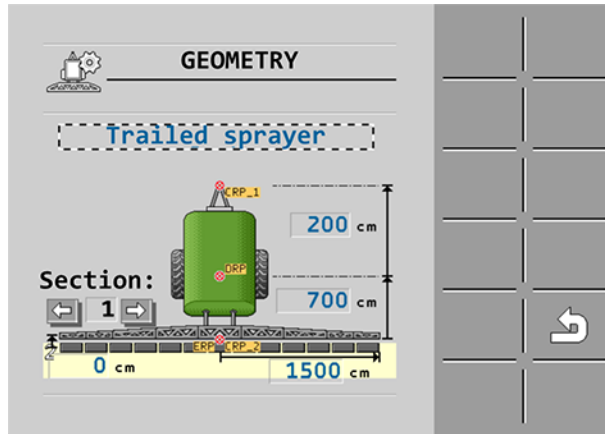



2. Select the sprayer type in the topmost box.
A diagram of the sprayer appears.
3. Measure the distances shown in the figure.
4. Enter the distances measured.

Configuring the Raven Direct Injection

If your sprayer is equipped with a direct injection manufactured by Raven, you have to configure it before using it for the first time.

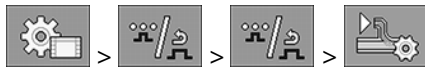
1. Switch to the "INJECTION" screen:







2. Activate the units that you want to use.
3.  - Switch to the calibration and diagnostics screen.
4. Assign the individual units to each "ECU number".

You have configured the Raven direct injection.

Depending on the status, the following icons can appear:

Status of the Raven Direct Injection

Display Screen		Meaning
Calibration	Work	
		The ECU did not recognise the injection unit on the ISOBUS.
		The ECU recognised the injection unit on the ISOBUS, but is not receiving any messages from this unit.

Display Screen		Meaning
Calibration	Work	
		The ECU recognised the injection unit on the ISOBUS, and is also receiving messages from this unit. There is a connection between the ECU and the injection unit. But the injection unit is currently not ready.
		The ECU recognised the injection unit on the ISOBUS, and is also receiving messages from this unit. There is a connection between the ECU and the injection unit. The injection unit is ready, but the pump is switched off.
		The ECU recognised the injection unit on the ISOBUS, and is also receiving messages from this unit. There is a connection between the ECU and the injection unit. The injection unit is ready and the pump is switched on.

Calibrating the Sensors for Reproducing the Boom Slope

The purpose of the calibration process is to detect and save the boom position at maximum slope and in the horizontal position.

You must perform the calibration in the following instances:

- Prior to initial start-up.
- When the boom slope is not displayed correctly.

The current boom position can appear at the following places:

- Work screen
- "BOOM SLOPE CONTROL" screen

To calibrate the angle sensor:

1. Position the field sprayer on level ground.
2. Switch to the "Boom slope control" screen:



The "Boom Slope Control" screen appears.

3. - Press.
4. Position the boom horizontally. The actual boom position is important here. The display on the screen is not calibrated yet at this time.
5. - Initiate calibration of the horizontal position.



The following progress icon appears:

You must now start the calibration within a few seconds.

6.  - Start calibration.

Horizontal position is being saved as long as the  icon appears.

You have saved the horizontal position.

7. Slope the boom to the right.

8.  - Calibrate the slope to the right. Proceed in the same way as for the horizontal position.

9. Slope the boom to the left.

10.  - Calibrate the slope to the left.

Field Sprayer with Two Circulations and ECUs

For field sprayers with two manifolds and booms, which are controlled by two ECUs, you must configure each ECU for the equipment of the respective boom.

There are also the following settings:

- You must decide which system should be the main system and which should be the auxiliary system. On the main ECU, mark the 2nd connector parameter.
- You must set the geometry on both ECUs.
- You have to select an operating device for each boom.

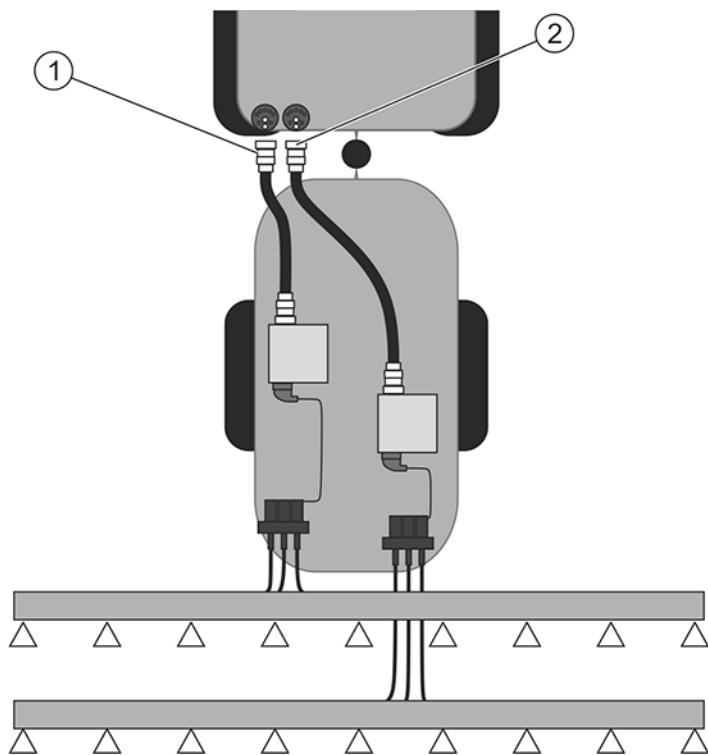

Field sprayer with two booms at the rear.

Item	Meaning	Item	Meaning
1	Main system	2	Auxiliary system

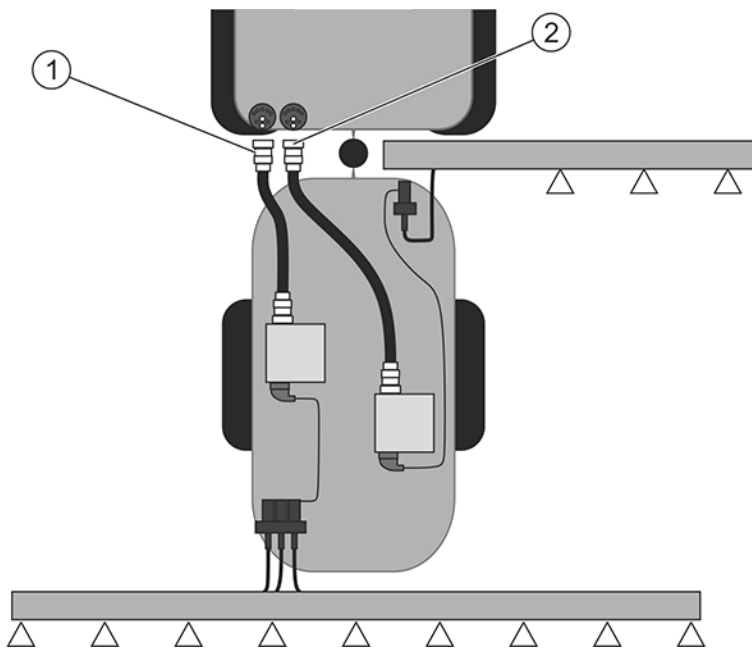

Field sprayer with one boom at the front and one at the rear.

Item	Meaning	Item	Meaning
1	Main system	2	Auxiliary system

Identifying the ECU

For systems with two ISOBUS ECUs, you must identify both ECUs. You must activate the so-called second connector on the main ECU.

The second connector is a virtual connection for a second ISOBUS ECU. By activating the parameter, you are telling the ISOBUS system that there is a second implement in addition to the implement that is controlled by the main ECU.

The terminal can then take account of the geometry of both implements and thus enable section control. In doing so, the position of the second implement is always indicated relative to the position of the first implement.

A second manifold with boom can be considered as the second implement - like the example in these instructions. However, a different implement can also be mounted behind the field sprayer or in front of the tractor.

Because the system described here does not have a second ISOBUS power socket, you must use a second ISOBUS power socket on the tractor.

Parameter	Standard system without auxiliary ECU	With two manifolds: Main ECU	Auxiliary ECU
No. 'ECU Number'	1	1	2-32
2nd connector	Do not activate	activate	Do not activate

Before you begin, make sure you have entered the user and service password.

1. Switch to the "ISO 11783" screen:

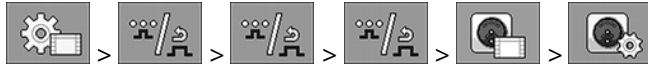

The "ISO 11783" screen appears:

2. Configure parameter.

Geometry on a Field Sprayer with Two ECUs

You must measure and enter the following distances:

- On the main ECU: Distances between the main boom, the axle, and the attachment point.
- On the auxiliary ECU: Distance between the main boom (CRP_2) and the auxiliary boom.

On systems with a one-sided folding auxiliary boom, you must also enter the distance **DRP_Y**:

- The boom is located only on the left side: 0cm
- Boom on the right side: Working width of the boom in cm

Enter the Sprayer Geometry in the Main ECU

Before you begin, make sure you have set the second connector on the main ECU.

1. Switch to the "Geometry" screen in the application of the main ECU:



The following screen appears:

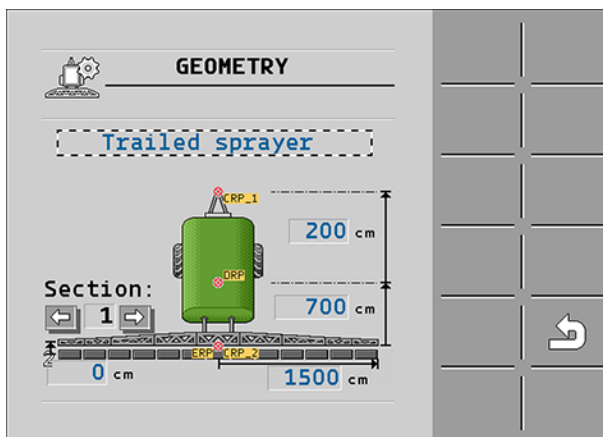

There are two red dots on the diagram: CRP_1 - Attachment point; DRP - Axle; CRP_2 - Work point of the main boom. You must also measure the distance from this point to the second boom later.

2. On the line above the drawing, set the corresponding sprayer type.
3. Enter the measured values.

Enter the Sprayer Geometry in the Auxiliary ECU

1. Switch to the "GEOMETRY" screen in the application of the auxiliary ECU:



The following screen appears:

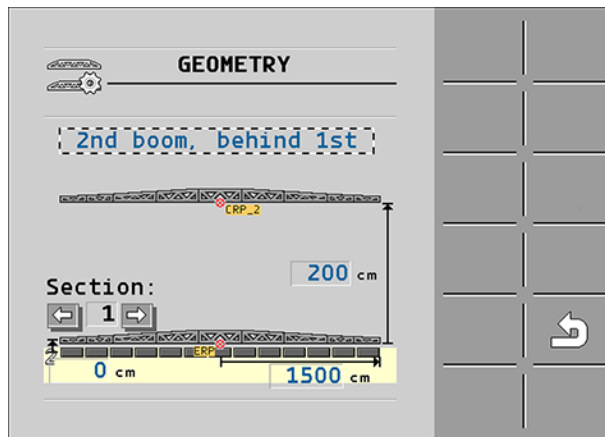

The red dot **CRP_2** marks the first boom.

2. On the line above the drawing, select whether the second boom is located in front of or behind the first boom (looking in the direction of travel): "2nd boom, behind the 1st" or "2nd boom, front of 1st"
3. Measure the distance between CRP_2 and the second boom (ERP) and enter this value.

Activating Licenses

If you want to extend the functions of your ECU, you can activate additional licenses. You need a password for this.

1. Switch to the "Licenses" screen:



The "Licenses" screen appears.

2. In the "App" parameter, select the application that you want to activate.
3.  - As an option, you can activate a temporary license for the selected application.

In the bottom area, you can see how long you have already been working with a temporary license. You can test each application for 50 hours.

4. Use the "PTx code" to order a password from PTx Trimble.

5. Enter the password.
6. Restart the ECU.

The license is now activated.

Assigning the Joystick Buttons





If you are using the AUX2 auxiliary protocol, you can assign the buttons on the joystick yourself.

The buttons on the joystick can be assigned in the "Service" application of the terminal. You can read how to do this in the operating instructions for the terminal.

The functions that can be assigned to the individual buttons can also be seen in the "Service" application of the terminal. You can always recognize the respective function by the function icon.

The meaning of the respective function icons can be found in the different sections of these instructions.

In addition, for some functions, you can decide whether you want to operate the respective function with a button or with a switch. You can see the mode of operation by the respective icon. If an icon does not appear behind a function, operation takes place with a function icon, i.e., like a button.

Icon	Meaning
	The function is operated with a button.
	The function is operated with a switch.
	The function is operated with a switch that has three different positions. After actuation, the switch always goes back to the center position.
	Determines whether the function is actuated as a button like on the joystick or as a switch like on the S-Box.

Extension: TRAIL-Control

- For Your Safety
- About TRAIL-Control
- Mounting and Installation
- Basic Control Principles
- Operating TRAIL-Control on the Field
- Configuring TRAIL-Control

For Your Safety

When using TRAIL-Control, there is a danger zone that spreads several metres away from the tractor and from the towed implement in all directions. The bigger the trailed implement, the bigger the hazard area. For example: The greater the width of a spraying boom on a field sprayer, the greater the range when it is unfolded, and the larger the hazard area.

DANGER!

RISK OF INJURY DUE TO UNCONTROLLED MOVEMENTS OF THE IMPLEMENT

- **ENSURE THAT NOBODY ENTERS THE HAZARD AREA.**
- **SWITCH THE SYSTEM OFF IMMEDIATELY AS SOON AS SOMEONE ENTERS THE HAZARD AREA.**



As soon as you have installed and switched on the system, ensure that nobody is in the hazard area.

When TRAIL-Control is switched on, there is a risk of uncontrolled movement of the drawbar or stub axle caused by pressure fluctuations in the hydraulic system.

For example, pressure fluctuations can occur in the following situations:

- If there is a failure in the hydraulic system.
- If you use the hydraulic system for purposes other than controlling the drawbar and stud axle steering.

The hazard area may only be entered if the following requirements are met:

- System is switched off.

All maintenance, configuration, and inspection work is performed with the system switched off.

About TRAIL-Control

System Functions

Functions

TRAIL-Control serves to steer the trailed implement during field operation. In doing so, it supports the driver in the following ways:

- It keeps the trailed implement in the tractor track.
- When working on slopes, it steers the trailed implement up the slope so that it does not slip out of the tractor track.

Versions

The system can control two types of steering systems:

- Drawbar steering - These systems only steer the drawbar to the left or right to influence the course of the trailed implement.
- Stub axle steering - These systems steer the steering axle of the trailed implement to the left or right to influence the course of the trailed implement.

Requirements

The following requirements must be met for TRAIL-Control to work:

- Minimum speed = 3 km/h. Steering is not possible at lower speeds.
- (Default) Maximum speed = 15 km/h. If you drive faster than 15 km/h, the TRAIL-Control function will be automatically switched off.

NOTE – The implement manufacturer is capable of increasing or decreasing the maximum speed before delivering the field sprayer to adjust it for the characteristics of the field sprayer and its intended use.

- The maximum speed can be adjusted for the trailed implement and increased by the implement manufacturer.
- Minimum oil throughput for the hydraulic system of the tractor = 25 l/min. The minimum oil throughput may be greater for large field sprayers.

System Overview

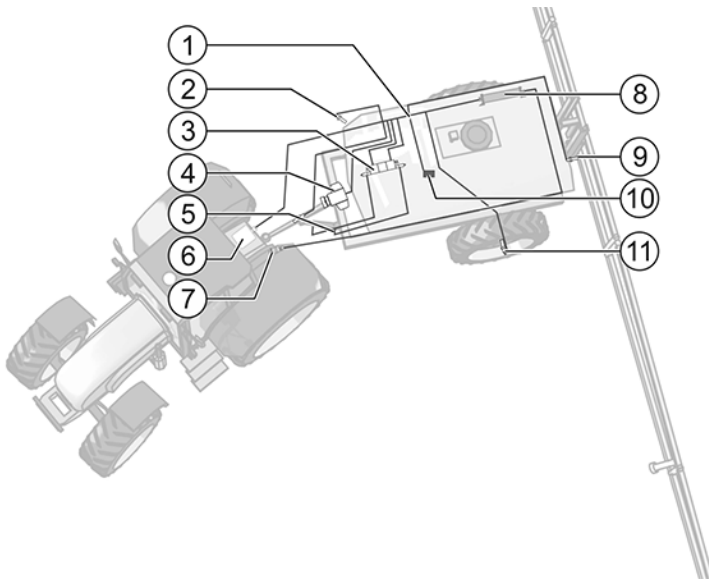

Example for a system with drawbar steering

Item	Description
1	Main cable harness
2	Ladder sensor* The ladder sensor serves to detect whether a ladder has been extended on the trailed implement. In this case, TRAIL-Control is blocked and cannot be activated.
3	Proportional valve

Item	Description
4	Angle sensor Determines the angle of a hydraulic cylinder on the drawbar or on a stub axle. For systems with stub axle steering, this sensor is installed on a stub axle.
5	Drawbar locking sensor* Sensor that detects when the drawbar has been locked with a pin.
6	Gyroscope with two brackets Detects changes in the driving direction of the tractor.
7	ISOBUS cable with connector Cable from the ISOBUS ECU to the ISOBUS power socket on the tractor.
8	ISOBUS ECU Control unit that is responsible for system operation.
9	"Boom unfolded" position sensor* Sensor that detects when the boom has been unfolded and is ready for field work. This is mandatory for using TRAIL-Control. The system is locked when the boom is folded in.
10	Sprayer slope sensor Sensor that detects the tilt of the trailed implement to enable the slope counter-steering function.
11	Wheel sensor* Serves to determine the vehicle speed.

* - Optional sensors. Because there is a limited number of sensor inputs, not all of the optional sensors can be installed and used on the implement.

Mounting and Installation

Mounting the Gyroscope

The gyroscope is a sensor that determines the angular speed when the tractor changes direction.

To mount the gyroscope you must install the bracket on the tractor:

Bracket	Gyroscope in the bracket

The bracket on the tractor is used for fastening the gyroscope to the tractor for the duration of work on the field.

- Determine the position for mounting the bracket on the tractor.
The bracket must be mounted vertically and without vibration on the rear of the tractor.
Make sure that the connection cable of the gyroscope does not become too tight when fastened in the bracket
- CAUTION! Before drilling a hole, make sure that you will not damage any lines while drilling.**

3. Drill holes for the bolts.
4. Fasten the bracket.

The bracket must be fastened securely to prevent shaking while driving.

Using the Gyroscope

1. Fasten the gyroscope into the bracket on the tractor and screw tight with the wing screw.
The side with the TOP-OBEN label must be on the top:



2. After work, fasten the gyroscope into the bracket on the trailed implement and screw tight with the wing screw.

Checking the Installation Position of Sensors

You can measure the voltage on the sensor input of the ECU to check if the selected sensors are mounted correctly.

The following sensor voltages are correct:

Sensor Voltages

Sensor Type	Position During Measurement	Correct Voltage
Angle sensor	Center position: The drawbar (or wheels of the trailed implement) is (are) aligned to drive straight ahead.	2.5 V (+/- 0.1 V)
	Voltages when the trailed implement is steered to the maximum left or right.	Approx. 1.5 V and 3.5 V (+/- 0.1 V)
	Short circuit.	0.1 V
Slope sensor	The trailed implement is standing on level ground.	2.5 V (+/- 0.1 V)
Gyroscope	Sensor is in the bracket on the tractor. The tractor is at a standstill.	2.5 V (+/- 0.1 V)

Hydraulic System

Requirements for the Hydraulic System

To use the TRAIL-Control with the hydraulic block, the tractor's hydraulic system must meet the following requirements:

- Minimal oil throughput: 25 l / minute

For smaller quantities of oil, exact tracking is no longer possible, because the control system reacts too slowly.

- A NAS Class 6 pressure filter must be connected upstream from the hydraulic system.
- The hoses to the tractor must meet all of the criteria in the following table:

Connection	Max. Oil Speed	Hose Size (for 70 l/min pump delivery rate)
Pressure	5.5 m/s	DN 16
Tank	2 m/s	DN 25

Free-wheeling diodes must be installed in the connectors of the hydraulic system. The standard cables are fitted with free-wheeling diodes. If you need to replace a cable or a connector, you can order a replacement using the following part number: 30235990.

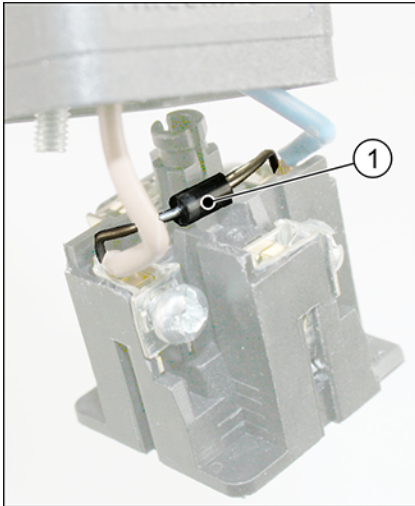

Free-wheeling diode

Connecting the Hydraulic Unit to the Tractor and Hydraulic Cylinder

In this section you will find out how to connect the hydraulic unit of the TRAIL-Control to the tractor's hydraulic system and the hydraulic cylinder.

All illustrations and instructions in this and the following sections have been compiled on the example of hydraulic units produced by the company Till.

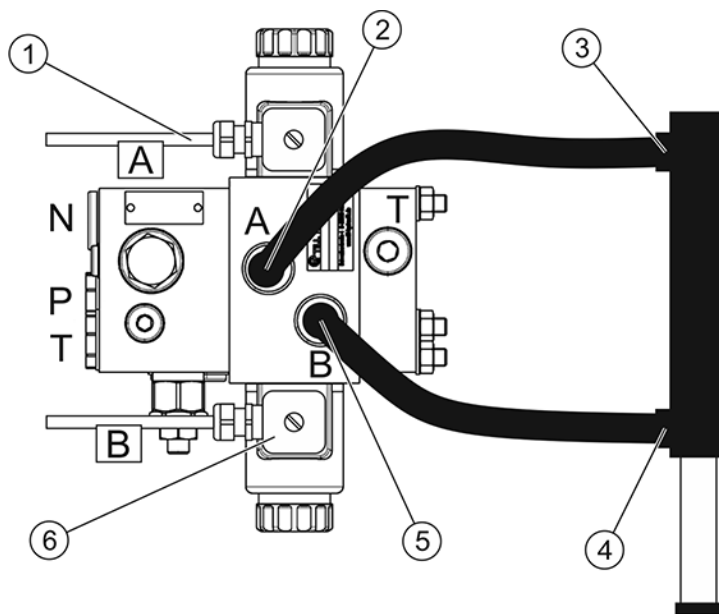

Hydraulic Unit from Till for the TRAIL-Control

Item	Description	Item	Description
1	Connector A with integrated free-wheeling diode	6	Connector B with integrated free-wheeling diode
2	Terminal A of proportional valve	N	Continuous operation (N)
3	Connection to the hydraulic cylinder run-out	P	Pressure (P)

Item	Description	Item	Description
4	Connection to the hydraulic cylinder run-in	T	Tank (T)
5	Terminal B of proportional valve		

1. Connect connector A to the magnets on hydraulic terminal A.
2. Connect connector B to the magnets on the hydraulic terminal B.
3. Connect terminal A of the proportional valve to the terminal for extending the hydraulic cylinder.
4. Connect terminal B of the proportional valve to the terminal for retracting the hydraulic cylinder.
5. Connect the tractor's pressure line to terminal P of the proportional valve.
6. Connect the return line to terminal T of the proportional valve.

Hydraulic Connection Diagrams

In this section you will find out how to set up the hydraulic system for the tractor and the implement in order to be able to use the TRAIL-Control.

The hydraulic system can only be installed by personnel, who possess a grounded knowledge in the field of hydraulics.

The following hydraulic connection diagrams were compiled on the example of a hydraulic system with a proportional valve from the company Till.

If you use a different hydraulic unit, contact the manufacturer in order to clarify how to connect the hydraulic system.

Abbreviations in the Hydraulic Connection Diagrams

Abbreviation	Meaning
A	Directional output A
B	Directional output B
P	Pressure Flow direction from tractor to implement
T	Tank (free return line) Flow direction to tractor
MT	Tank redirection
MP	Pressure redirection
LS	Load Sensing Hydraulic output control
AP	Proportional valve start plate from Till
SV	Proportional valve control valve from Till
EP	Proportional valve end plate from Till

Hydraulic Connection Diagram for Tractors with an Open Hydraulic Circuit

With this method the proportional valve of the TRAIL-Control is connected directly to the tractor's control unit.

Other functions of the implement, e.g. 'raising and lowering the boom' are controlled from the tractor via a separate valve. This valve is not depicted in the following illustration.

Suitable for:

- tractors with an open hydraulic circuit
- tractors with a Load Sensing hydraulic circuit

NOTE - The locking screw in terminal 'N' of the proportional valve of the TRAIL-Control must not be installed. Otherwise the pressure control valve of the tractor will constantly engage and no correct control will be possible.

CAUTION -

When using a tractor with a Load Sensing hydraulic system, the oil quantity should be restricted to approx. 30l/min. Thereby intense warming and noise generation can be avoided.

WARNING -

Risk of injury due to uncontrolled movements of the implement

If further functions are performed via other control valves of the tractor, uncontrolled machine movements may occur.



Before performing further functions via other control valves of the tractor, switch off TRAIL-Control.

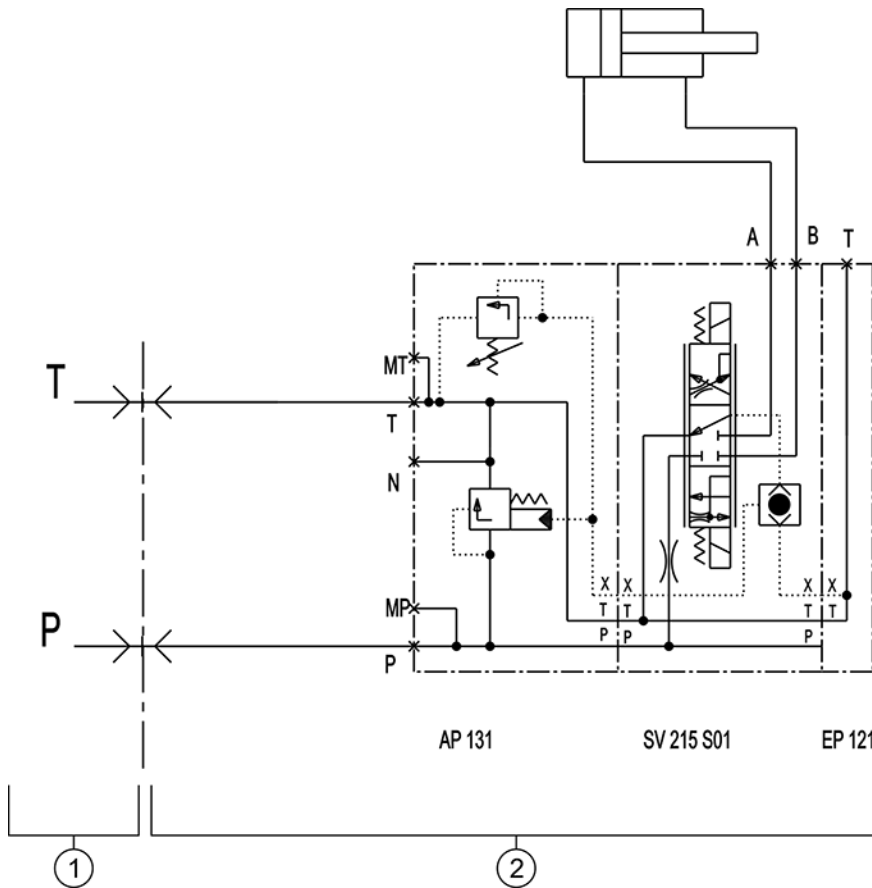

Open Hydraulic Circuit

Item	Description	Item	Description
1	Tractor side	2	Implement side

1. Connect the proportional valve of the TRAIL-Control to the tractor's control unit.

Hydraulic Connection Diagram for Tractors with an Open Hydraulic Circuit ('N' as Continuous Operation)

Suitable for:

- tractors with an open hydraulic circuit
- tractors with a Load Sensing hydraulic circuit

CAUTION -

When using a tractor with a Load Sensing hydraulic system, the oil quantity should be restricted to approx. 30l/min. Thereby intense warming and noise generation can be avoided.

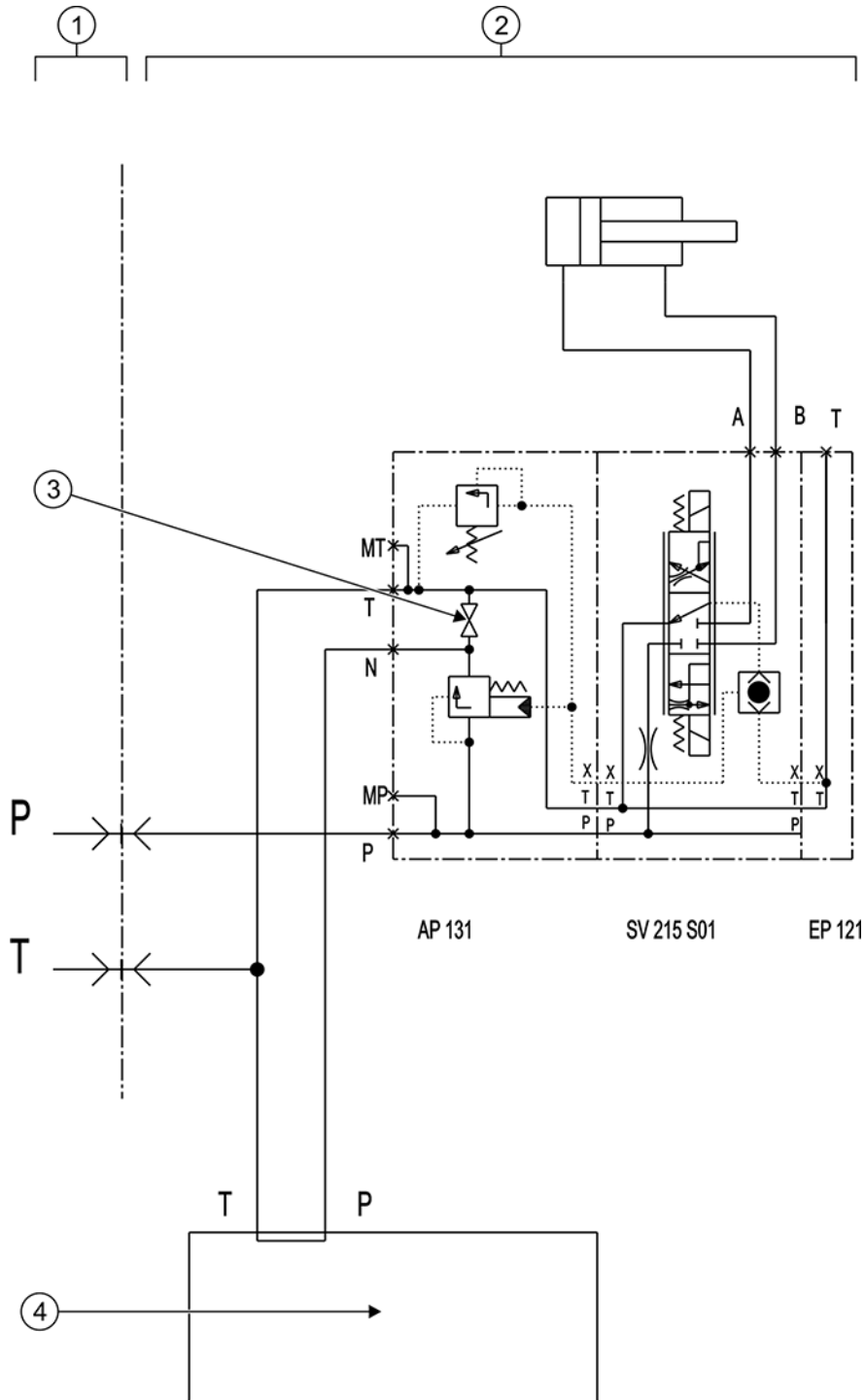

Hydraulic connection diagram for tractors with an open hydraulic circuit and 'N' as continuous operation

Item	Description	Item	Description
1	Tractor side	3	Locking screw N compliant with DIN 906 M14x1.5
2	Implement side	4	Valve unit 2 A further valve unit on agricultural equipment

1. Install the locking screw in terminal "N" of the TRAIL-Control's proportional valve.
 If you don't install the locking screw, the proportional valve will have no function, because the oil will flow back to the tractor's tank depressurized.
2. Connect the proportional valve of the TRAIL-Control to the tractor's control unit.
3. Connect all other functions of the implement, e.g. 'raising and lowering the boom' to valve unit 2.
4. Connect valve unit 2 with the proportional valve via terminal 'N'. Via this connection the second valve unit is supplied with 'oil'.
5. Set up valve unit 2 for use in a closed system.

Hydraulic Connection Diagram for Tractors with a Closed Hydraulic Circuit

Suitable for:

- tractors with a closed hydraulic circuit

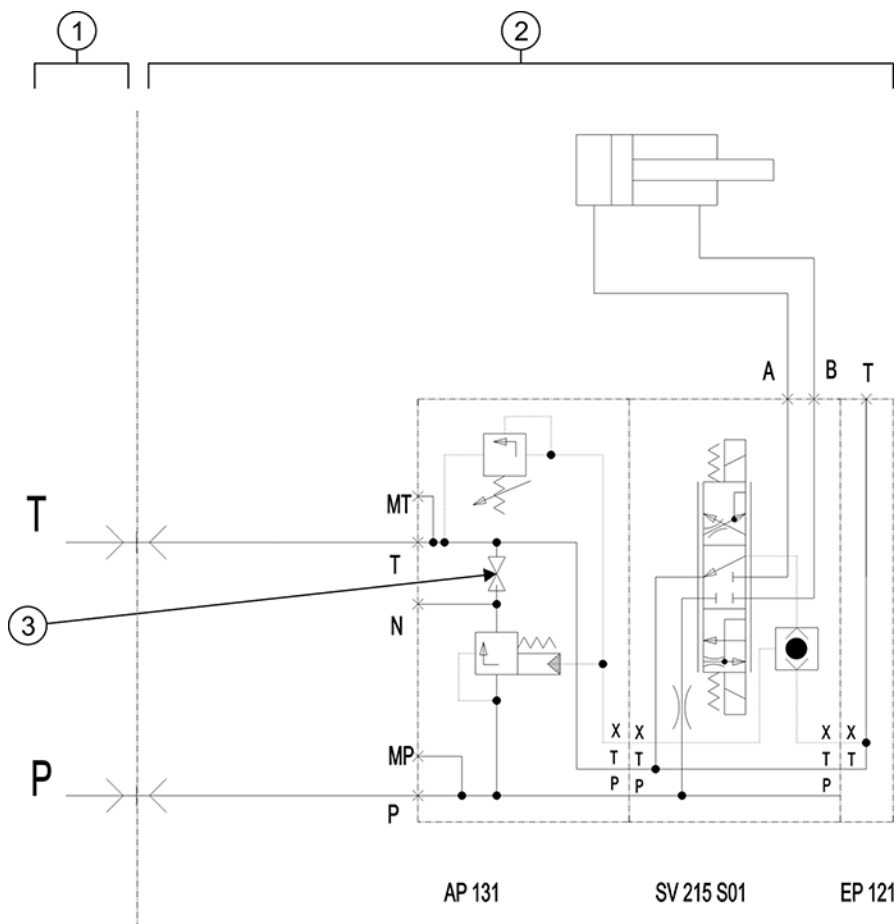

Hydraulic connection diagram for tractors with a closed hydraulic circuit

Item	Description	Item	Description
1	Tractor side	3	Locking screw N compliant with DIN 906 M14x1.5
2	Implement side		

1. Install the locking screw in terminal "N" of the TRAIL-Control's proportional valve.

If you don't install the locking screw, the proportional valve will have no function, because the oil will flow back to the tractor's tank depressurized.

2. Connect the proportional valve of the TRAIL-Control to the tractor's control unit.
3. Connect all other functions of the implement, e.g. 'raising and lowering the boom' to valve unit 2. This valve unit is not depicted in the connection diagram, because it is not connected with the proportional valve.

Hydraulic Connection Diagram for Tractors with a Closed Hydraulic Circuit and 'N' as Continuous Operation

Suitable for:

- tractors with a closed hydraulic circuit

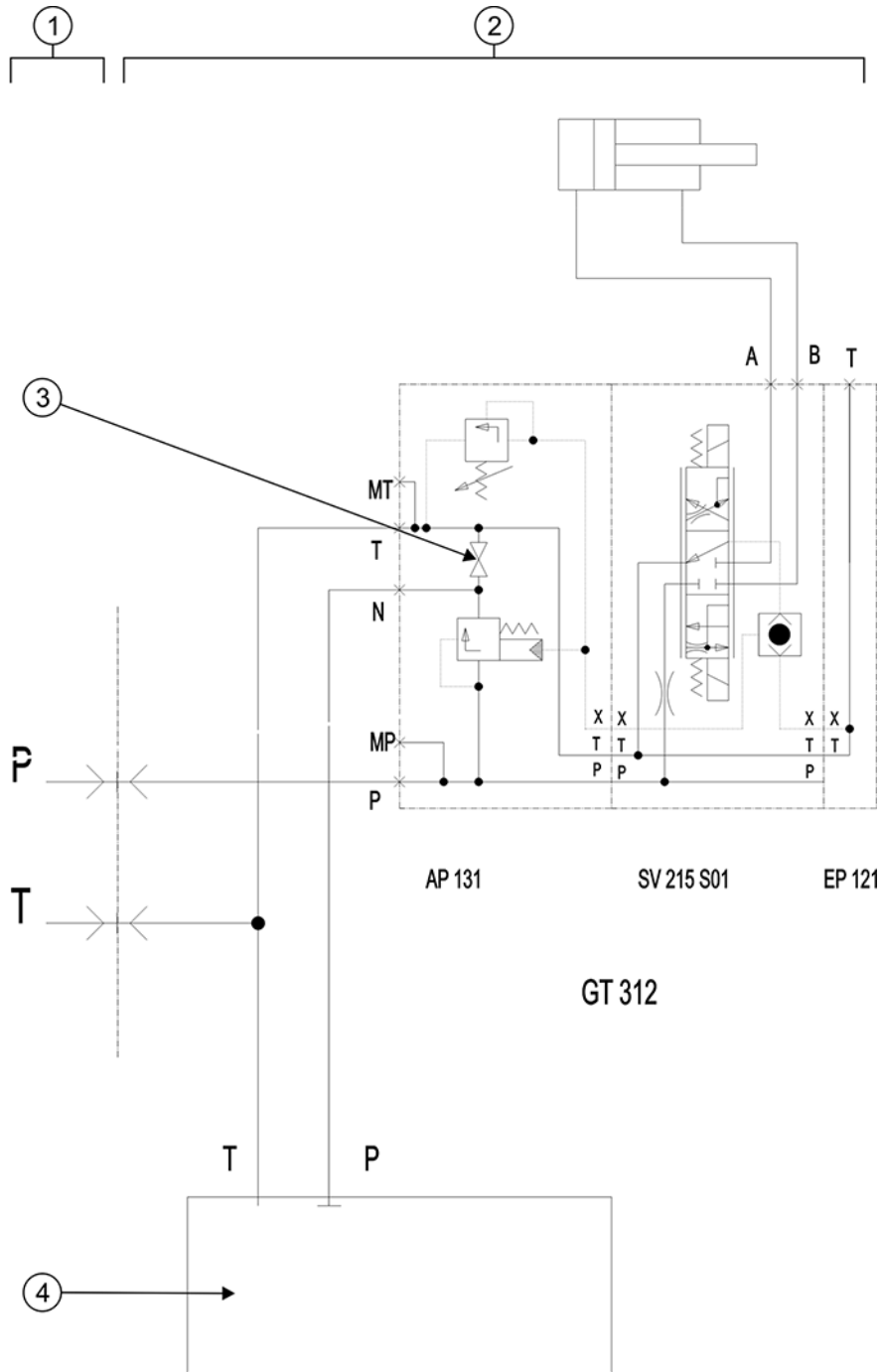

Hydraulic connection diagram for tractors with a closed hydraulic circuit and 'N' as continuous operation

Item	Description	Item	Description
1	Tractor side	3	Locking screw N compliant with DIN 906 M14x1.5
2	Implement side	4	Valve unit

1. Install the locking screw in terminal "N" of the TRAIL-Control's proportional valve.
If you don't install the locking screw, the proportional valve will have no function, because the oil will flow back to the tractor's tank depressurized.
2. Connect the proportional valve of the TRAIL-Control to the tractor's control unit.
3. Connect all other functions of the implement, e.g. 'raising and lowering the boom' to valve unit 2.
4. Set up the valve unit for use in a closed system.
5. Set up valve unit 2 for use in a closed system.

Hydraulic Connection Diagram for Tractors with a Load Sensing Hydraulic System

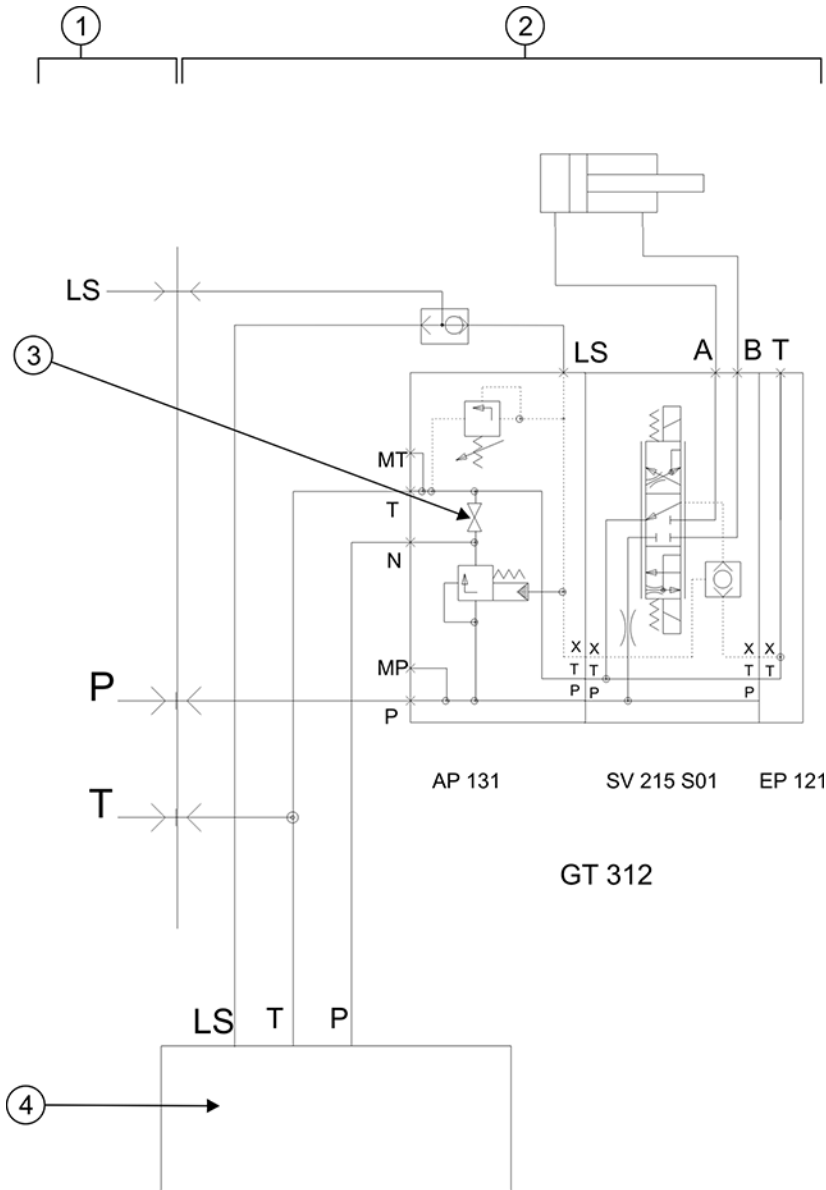

Hydraulic Option: Load Sensing Hydraulics

Item	Description	Item	Description
1	Tractor side	3	Locking screw N compliant with DIN 906 M14x1.5
2	Implement side	4	Valve unit

Installing a Locking Screw in the Proportional Valve

The locking screw completes the connection between T and N in the proportional valve. Thereby, pressure can be built up for the subsequent system.

The locking screw is delivered together with the hydraulic unit and can be found loose in the packaging.

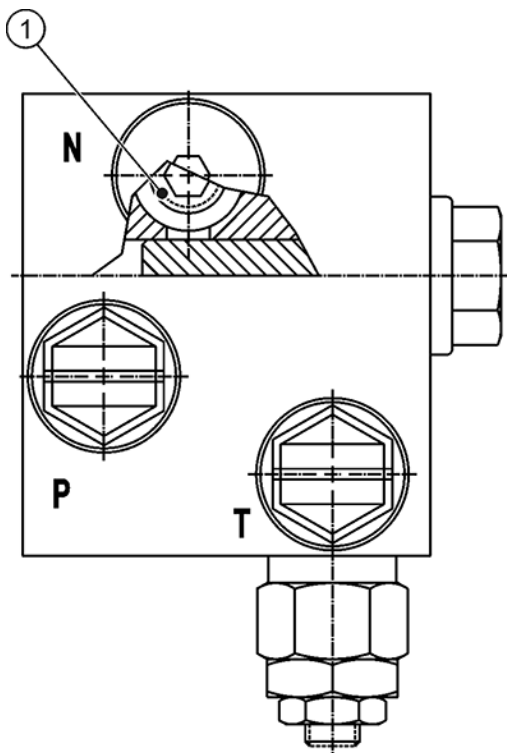

Hydraulic Unit with Locking Screw

Item	Description
1	Locking screw

NOTE - Non-Standardized Screw Sizes

To install the locking screw, you will need a size 7 hex key.

1. Unscrew the cover of the locking screw in terminal N.
2. Insert the locking screw in terminal N.
3. Screw tight the cover of the locking screw in terminal N.

Load-Holding Valve

For machines with drawbar steering it can occur that the pressure in the hydraulic system becomes too great for the proportional valve.

This can have various consequences:

- On a slope the machine may start to drift.
- The steering may oscillate when large rods are in use.

In order to resolve this problem, you can install the load-holding valve between the proportional valve of the TRAIL-Control and the hydraulic cylinders of the drawbar steering.

The load-holding valve is installed in the hydraulic lines to the cylinder.

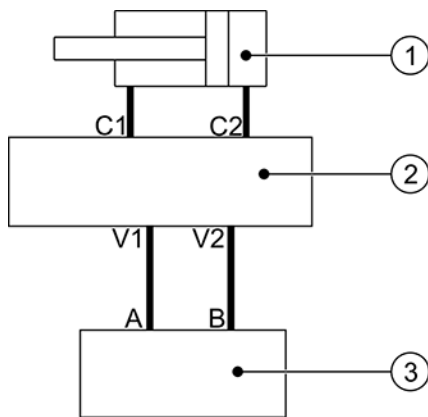

Position of the Load-Holding Valve

Item	Description	Item	Description
1	Hydraulic cylinder	C1 C2	Illustration of the terminals on the valves.
2	Load-Holding Valve	V1 V2	
3	Proportional valve	A B	

Basic Control Principles

Switching TRAIL-Control On and Off

DANGER!



MOVING IMPLEMENT

BEFORE YOU SWITCH ON THE SYSTEM, MAKE SURE THAT THERE ARE NO PERSONS OR OBJECTS NEARBY.



Before you switch on the system, make sure:

- The boom is unfolded. The “Boom unfolded” sensor (if the sensor is installed) is activated.
- The drawbar is not mechanically locked.
- The ladder is not extended or unfolded. (If the ladder sensor is installed).
- The gyroscope is fastened on the tractor.

1.  /  - Switch on TRAIL-Control. By pressing again, you can switch off the system.

The system is switched on, however, it is only working in manual mode. This means that you must actuate a function icon to steer the trailed implement.

New icons appear on the work screen.

On systems with axle steering:

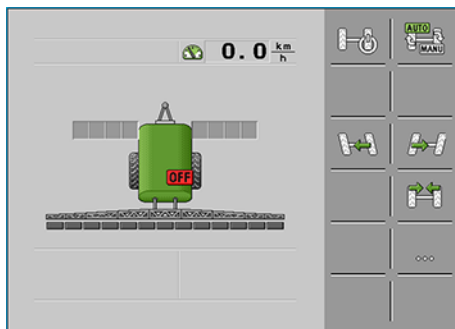

On systems with drawbar steering:

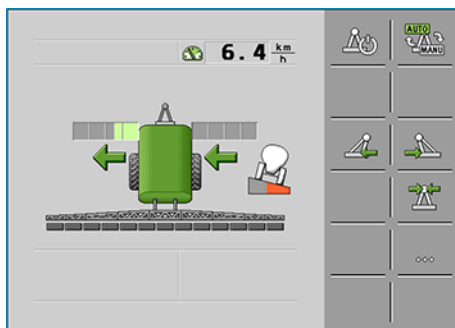

Layout of the Work Screen

This screen allows you to:

- see the status of the system,
- operate the system using function icons.

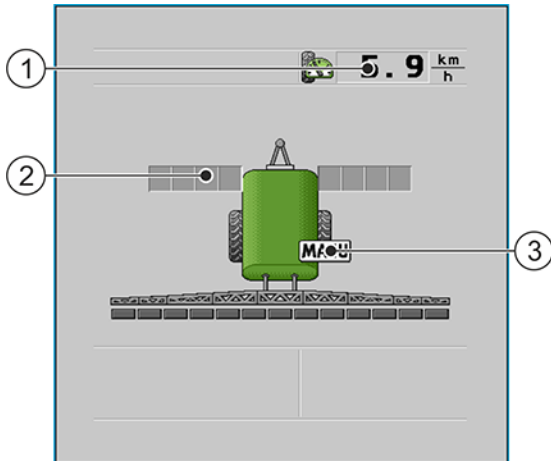

Example: Work screen when the implement is standing still on a system with drawbar steering

Item	Description	Item	Description
1	Current speed	3	Icon: manual mode is activated
2	Scale of the deflection		

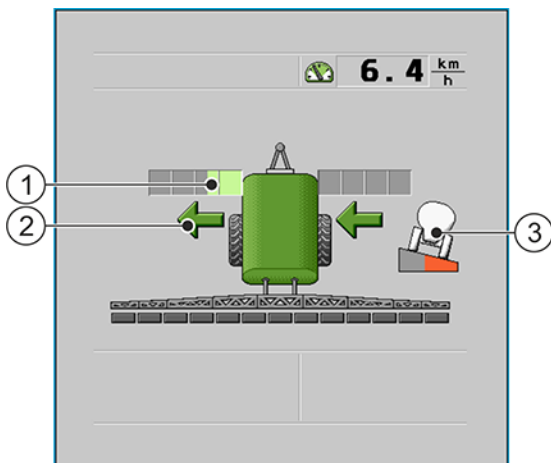

Example: Work screen when the implement is working on a system with drawbar steering







Item	Description	Item	Description
1	The deflection is also shown on a scale.	3	Icon: Slope counter-steering is activated. The scale indicates how much is steered against the slope.
2	The arrows show the direction in which the trailed implement is being steered.		

Beside the work screen, there are function icons that serve to operate the system.

Steering Icon		Meaning
Drawbar	Axle	
		Switches TRAIL-Control on and off.
		Steers the implement to the left.
		Steers the implement to the right.
		Centers the implement.
		Calls up the screens with settings.
		Activates the slope counter-steering function.
		Calls up the "CALIBRATION" screen.
		Starts the calibration of the slope sensor (if equipped).
		Starts the calibration of the middle position.
		Starts the calibration of the left limit stop.
		Starts the calibration of the right limit stop.
		Starts the calibration of the proportional valve.

The following icons may appear on the work screen when TRAIL-Control is being operated:

Meaning	Drawbar Steering	Axle Steering
No TRAIL-Control.		
TRAIL-Control is installed but is deactivated.		
TRAIL-Control is in manual mode.		

Meaning	Drawbar Steering	Axle Steering
TRAIL-Control is in automatic mode.		
The drawbar is locked with a pin		
The implement is being steered to the left.		
The implement is being steered to the right.		

Operating TRAIL-Control on the Field

Steering the Trailed Implement

DANGER!

DANGER OF INJURY FROM TRAILED IMPLEMENT MOVEMENT

THE TRAILED IMPLEMENT MOVES TO THE SIDE DURING STEERING.

THIS MAY CAUSE DANGER FOR PERSONS AND MATERIALS IN DIRECT PROXIMITY TO THE TRAILED IMPLEMENT.

ENSURE THAT NOBODY IS IN THE RANGE OF THE IMPLEMENT BEFORE STEERING THE TRAILED IMPLEMENT.



Steering in Automatic Mode

When you work in automatic mode, the trailed implement is steered automatically.

The gyroscope measures the change in direction of the tractor and the ECU calculates the required angle for steering the trailed implement.



The icons on the work screen show the direction in which the trailed implement is being steered.

Steering in Manual Mode

In manual mode, you must steer the trailed implement manually.

To **drive to the right** in a curve:

1. Drive the tractor to the right.

2.  /  - Steer the trailed implement for driving to the right.



With drawbar steering: The drawbar is steered to the left.

With axle steering: The wheels are steered to the left.

Arrows pointing left appear on the work screen.

To **drive straight** ahead again:

1. Drive the tractor straight ahead.

2.  /  - Steer the trailed implement to the middle position.

The trailed implement slowly moves to the middle position.



An arrow appears on the work screen. It shows the direction in which the drawbar or axle is steering.

If the implement is centred, the following symbol appears:



To **drive to the left** in a curve:

1. Drive the tractor to the left.

2.  /  - Steer the trailed implement for driving to the left

With drawbar steering: The drawbar is steered to the right.

With axle steering: The wheels are steered to the right.

Arrow pointing right appear on the work screen.

Steering the Trailed Implement Against the Slope

For working on slopes, you can use the 'slope counter-steering' function.

Mode of Operation

When you activate the 'slope counter-steering' function, you can offset the track of the trailed implement to the left or right. The direction in which the track is offset depends on if the slope climbs or declines to the left or right of the implement.

The aim of the "slope counter-steering" function is to prevent the trailed implement from driving inclined to the direction of work on a slope.

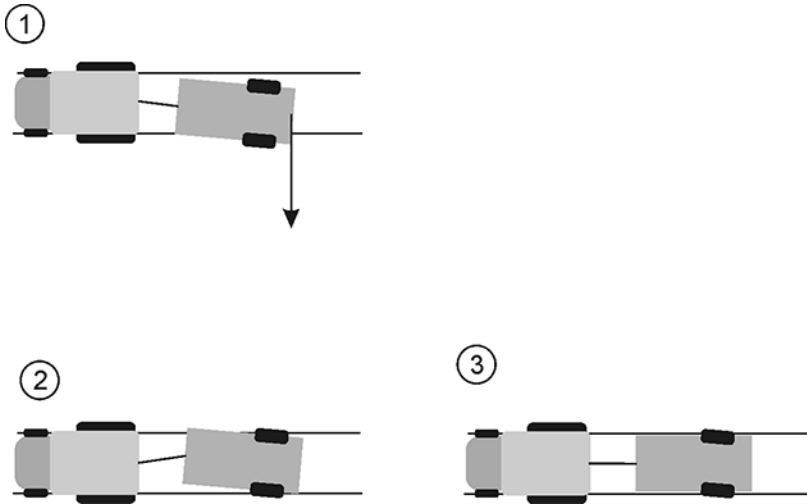

Steering the trailed implement against the slope

Item	Description	Item	Description
1	Without TRAIL-Control	3	TRAIL-Control with stub axle steering
2	TRAIL-Control with drawbar steering		



Slope countersteer

Item	Description
1	Slope direction
2	Degree of the slope. Measured by the slope sensor. On level ground, the  icon must appear here when the function is activated. If this is not the case, the slope sensor is not calibrated. The slope sensor is calibrated during the TRAIL-Control calibration. Repeat this calibration when the slope sensor has to be calibrated.
3	Steering direction of the system. While driving, the system steers the trailed implement against the slope until the desired angle is achieved. Then the arrow is no longer displayed.

To activate the “Slope counter-steering” function:

1. Switch to the “TRAIL-Control” screen:



or

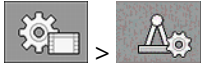

2.  - Activate or deactivate function.

On the screen, you can see whether the function is activated:



- Function enabled







- Function disabled.

Using Slope Counter-Steering in Automatic Mode

When you work in automatic mode, the trailed implement is steered automatically.

Before you begin to steer against the slope in automatic mode, make sure:

- The trailed implement is equipped with a slope sensor.
- During the calibration of TRAIL-Control, the slope sensor was mounted on the frame of the sprayer. The sensor position has not changed since.
- Automatic mode is activated.
- "Slope counter-steer" function is activated.
- The vehicle with the trailed implement is moving on the slope.

1.  ,  or  ,  - Manually steer the trailed implement to the correct position behind the tractor.



The work screen displays the icon . The red colour marks the target position of the angle sensor on the drawbar.

Each time you press a function icon, the triangle becomes more or less red in colour.

TRAIL-Control will try to steer the trailed implement into this position, until you correct the position manually again.

If you use a joystick, you can also correct the position manually.

2. After turning, when the slope lies on the other side of the trailed implement, the angle will be reproduced on the other side.

Using slope Counter-Steering in Manual Mode

In manual mode, you must steer the trailed implement manually against the slope. Here, you can decide yourself whether the trailed implement should follow the track of the tractor or whether it should be offset.

Preparing TRAIL-Control for Road Driving

Before driving with the field sprayer on a public road, you must switch TRAIL-Control **off** and if possible lock it with a locking pin.

DANGER!

RISK OF ACCIDENT THROUGH LATERAL MOVEMENT OF THE TRAILED IMPLEMENT

IN ROAD TRAFFIC, TRAIL-CONTROL CAN LEAD THE TRAILED IMPLEMENT TO THE SIDE OF THE TRACTOR TRACK. THIS MAY CAUSE A TRAFFIC ACCIDENT.

BEFORE YOU DRIVE ON A ROAD:

- **STEER THE TRAILED IMPLEMENT INTO THE MIDDLE POSITION.**
- **SWITCH OFF TRAIL-CONTROL.**
- **LOCK TRAIL-CONTROL.**

DANGER!

RISK OF ACCIDENT WITH UNCALIBRATED TRAIL-CONTROL

IF THE MIDDLE POSITION IS NOT CALIBRATED, THE TRAILED IMPLEMENT MAY MOVE WITH AN OFFSET RELATIVE TO THE TRACTOR'S TRACKS. THIS MAY CAUSE A TRAFFIC ACCIDENT.

BEFORE YOU DRIVE ON A ROAD:

- **CALIBRATE TRAIL-CONTROL.**
- **ENSURE THAT WHEN DRIVING STRAIGHT AHEAD, THE TRAILED IMPLEMENT IS PULLED IN A LINE BEHIND THE TRACTOR.**
- **SWITCH OFF TRAIL-CONTROL.**
- **LOCK TRAIL-CONTROL.**

Driving in Reverse

The operation of the trailed implement when driving in reverse depends on several factors:

- If no reverse driving signal is available, you can deactivate TRAIL-Control or set it to manual mode before driving in reverse.
- As a standard, TRAIL-Control stops working if a reverse driving signal is detected. In this case, the automatic mode remains activated, but the hydraulic valves are not being controlled.
- You can configure the reaction for TRAIL-Control when a reverse driving signal is detected. To do so, read section: Configuring automatisms when driving in reverse.



When a reverse driving signal is detected, a flashing icon always appears on the work screen:



Locking TRAIL-Control

If the drawbar can be locked with a locking pin, the system can monitor this locking device with a lock sensor. As long as the lock sensor detects locking, the system will be blocked. During this time, the hydraulic valves cannot be controlled.

1. Activate manual mode.

The work screen displays the icon:  or 

2. Steer the trailed implement to the middle position.

Drawbar or stub axle will be steered to the middle position.

Lock drawbar steering with the locking pins.

The work screen displays the icon 

TRAIL-Control is ready for driving on the road.

Configuring TRAIL-Control

Adjusting the Configuration to the Tractor

As a user, you have the option of changing several parameters. These can slightly influence the reaction of the system or enable connection to a different tractor.

Before you begin to call up the parameters, make sure the Start screen is called up.

1. Switch to the "TRAIL-Control" screen:

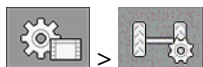

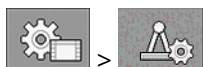

or



The "TRAIL-Control" screen appears.

2. Configure the parameters according to the specifications in the parameter list.

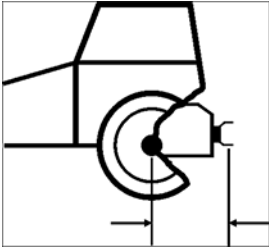
Parameter	Description
Slope Countersteer	<p>You can activate the slope counter-steering using the  function icon.</p> <ul style="list-style-type: none">  - Slope counter-steering deactivated  - Slope counter-steering activated - The system steers the trailed implement as soon as the slope sensor detects a slope. The system always steers the implement up the slope. <p>This function can only be configured when the TRAIL-Control system is activated.</p> <p>To prevent problems during operation, deactivate this parameter when you are not working on slopes.</p>
Compensation Time	<p>Enter only for trailed implements with a bang-bang valve.</p> <ul style="list-style-type: none"> The greater the value, the earlier cornering is commenced in automatic mode. The lesser the value, the later cornering is commenced in automatic mode. <p>Normally the value is between: 700 ms and 1000 ms.</p>
Hydraulic Flow Gain	<p>Enter only for implements with a proportional valve.</p> <p>Hydraulic flow is a value for setting the steering speed.</p> <p>Normally the value is between: 1.5 %/° and 3 %/°</p>
Deviation Tolerance	<p>The deviation tolerance influences the behaviour of steering in the central position area.</p> <p>The lower the tolerance is set, the more sensitive the control reacts to small changes.</p> <p>Normally the value is between: 2° and 3°</p>
Track Width	<p>Sprayer track width - distance between the centre of the wheels on the axle.</p>
Tractor Axle<->Coupling	<p>Distance between the center of the rear axle of the tractor and the towing hook of the tractor.</p> 

Calibrating TRAIL-Control

DANGER!

DANGER OF INJURY FROM TRAILED IMPLEMENT MOVEMENT

WHEN CALIBRATING THE PROPORTIONAL VALVE, THE TRAILED IMPLEMENT MOVES AUTOMATICALLY.

ENSURE THAT NOBODY IS IN THE REGULATION RANGE OF THE TRAILED IMPLEMENT.



ABOUT THE CALIBRATION WITH THE OR FUNCTION KEY AS SOON AS SOMEONE APPROACHES THE TRAILED IMPLEMENT.

When should you calibrate?

- Prior to initial start-up.
- At the start of each season.
- When inaccuracies occur.
- If you use the ECU on another tractor.

There are three steps involved in calibrating TRAIL-Control:

- **Step 1:** Calibrate the slope sensor.

To do so, the slope sensor must be installed. Its position may no longer be changed after this.

- **Step 2:** Teach-in the central position and limit stops.

In this step you teach the ECU the position of the drawbar and/or the axle in the middle, left and right positions.

The ECU calculates all intermediate positions itself.

- **Step 3:** Calibrate the hydraulics of the proportional valve

Only for trailed implements with proportional valves

In this step, the trailed implement is automatically steered to both sides and the voltages are measured.

The calibration runs automatically.

Calibrating the Slope Sensor

Before you begin, make sure:

- TRAIL-Control is in manual mode.
- Ground is not sloped. Slope sensor must not recognize any slope. Otherwise the "Slope counter-steering" function will not work properly.

1. Switch to the "Calibration" screen:



or





2. The "Calibration" screen appears.
3. Set up the trailed implement on flat ground in a line behind the tractor. Drive straight ahead for a few meters until the wheels of the field sprayer run precisely in the tracks of the tractor.
4. Stop the tractor as soon as the field sprayer is exactly in line behind the tractor.

5.  - Start the calibration of the slope sensor.

The following message appears:

“Slope sensor: Calibration is ready”

6.  - Confirm within 3 seconds. The time will be counted by a red clock: 

Calibration is initiated.

The following message appears:

“Slope sensor: Calibration running”

A blue clock shows the progress: 

The calibration is completed when the message “Slope sensor: Calibration running.” is no longer displayed.

You have calibrated the slope sensor.

Teaching-in the Central Position and Limit Stops - Phase 1: Recording the Middle Position

Before you begin, make sure:

- TRAIL-Control is in manual mode.
- Ground is not sloped. Slope sensor must not recognize any slope. Otherwise the “Slope counter-steering” function will not work properly.

1. Switch to the “Calibration” screen:





or

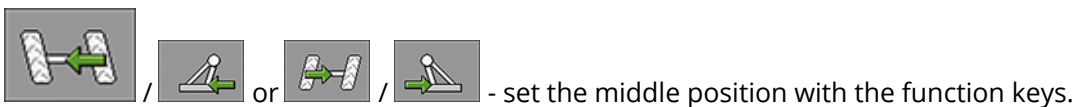

2. The “Calibration” screen appears.
3. Set up the trailed implement on flat ground in a line behind the tractor. Drive straight ahead for a few meters until the wheels of the field sprayer run precisely in the tracks of the tractor.





4. Stop the tractor as soon as the field sprayer is exactly in line behind the tractor.

5.  /  - Start the calibration of the middle position.

The following message appears:

“Middle Position: Calibration is ready”

6.  - Confirm within 3 seconds. The time will be counted by a red clock: 

Calibration is initiated.

The following message appears:

“Middle Position: Calibration running”



A blue clock shows the progress: 

Phase 1 is completed when the message “Middle position: Calibration running.” is no longer displayed.

You have calibrated the middle position.

7. You can start phase 2 of the calibration.



Teaching-in the Central Position and Limit Stops - Phase 2: Recording the Limit Stops

1.  /  - Steer the trailed implement fully to the left.

2.  /  - Start calibration.

The following message appears:

“Most Left Position: Calibration is ready”

3.  - Confirm within 3 seconds. The time will be counted by a red clock: 



Calibration is initiated.

The following message appears:

“Most Left Position: Calibration running”

A blue clock shows the progress: 



4. Wait until the message “Most left position: Calibration running.” is no longer displayed.

5.  /  - Steer the trailed implement fully to the right.

6.  /  - Start calibration.

The following message appears:

“Most Right Position: Calibration is ready”

7.  - Confirm within 3 seconds. The time will be counted by a red clock: 

Calibration is initiated.

The following message appears:

“Most Right Position: Calibration running”



A blue clock shows the progress:

- Wait until the message “Most right position: Calibration running.” is no longer displayed. Phase 2 of calibration has been completed.

Calibrating the Hydraulics of the Proportional Valve

You must only calibrate the hydraulics of the proportional valve when you use a trailed implement with proportional valve.

DANGER!

DANGER OF INJURY FROM TRAILED IMPLEMENT MOVEMENT

WHEN CALIBRATING THE PROPORTIONAL VALVE, THE TRAILED IMPLEMENT MOVES AUTOMATICALLY.



ENSURE THAT NOBODY IS IN THE REGULATION RANGE OF THE TRAILED IMPLEMENT.

ABORT THE CALIBRATION WITH THE  OR  FUNCTION KEY AS SOON AS SOMEONE APPROACHES THE TRAILED IMPLEMENT.

Before you begin, make sure:

- TRAIL-Control is in manual mode.
- Ground is not sloped. Slope sensor must not recognize any slope. Otherwise the “Slope counter-steering” function will not work properly.
- You have enough space to drive straight ahead for about 30 seconds.

- Switch to the “Calibration” screen:



or



- The “Calibration” screen appears.
- Set up the implement on flat ground in a line behind the tractor. Drive straight ahead for a few meters until the wheels of the field sprayer run precisely in the tracks of the tractor.



- set the middle position with the function keys.

- Stop the tractor as soon as the field sprayer is exactly in line behind the tractor.

5. Drive straight ahead very slowly. While driving, the friction of the wheel corresponds to the real working conditions and makes the calibration more precise. However, you can also perform this calibration while the implement is standing still.

6.  - Start calibration.

The following message appears: "Hydr. Output: Calibration is ready"

7.  - Confirm within 3 seconds.

The following message appears: "Hydr. Output: Calibration running."

The trailed implement (or its drawbar or stub axle) now moves slowly to the left and then slowly to the right.

This procedure may last up to 20 seconds.

The calibration is completed when the message 'Hydraul. Output: Calibration running.'" is no longer displayed.

8. Come to a stop.

Configuring the Automatic Centering

The system is capable of centering the position of the trailed implement in certain situations. With drawbar steering, this means positioning the drawbar straight, and with stub axle steering, aligning the wheels straight.

As the user, you can decide which automatism should be activated and configure them to a certain extent.

To activate the automatism:

1. Switch to the "TRAIL-Control" screen:



or

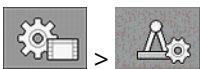

The "TRAIL-Control" screen appears.

2.  - Press.

The second page of "TRAIL-Control" appears.

An automatism is described on each line. On the left in the brackets, you can see the conditions under which a mechanism is executed. On the right, the effects.

3. To activate functions, set the check mark on the desired line. These functions will be explained in the following sections.

Centering When Exceeding the Maximum Speed

The system will center the trailed implement as soon as the maximum speed has been exceeded. The maximum speed is generally 9.32 mph, however, it can be increased by the manufacturer in some cases when the construction allows it.

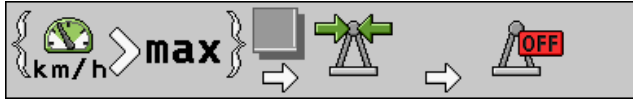

For activation, mark the box near these icons.

Mode of Operation

As soon as the maximum speed has been exceeded, an error message appears. At the same time, the trailed implement will be centered. It does this regardless of whether the system was previously working in manual or in automatic mode.



During the centering procedure, the icon for manual mode appears on the work screen:



The centering may not take longer than eight seconds. After this time, the function is aborted, regardless of whether the middle was reached. TRAIL-Control will then be deactivated.

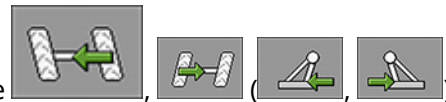

The automatic centering procedure can be aborted by pressing the function keys. Furthermore, the system is switched off.

Centering When Switching to Manual Mode

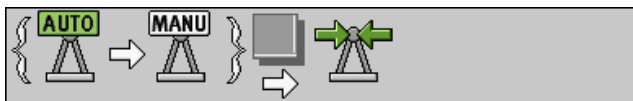

The system will center the trailed implement as soon as the operating mode is changed from automatic to manual.

If the steering system is actuated during the centering procedure, the centering is aborted. The system remains in manual mode.



For activation, mark the box near these icons.

Centering when Tapping the Centering Icon

When you are working in automatic mode and tap the  or  function icon, the system automatically centers the trailed implement. To do so, the system is switched to manual mode. In addition, you can define after how many seconds the automatic mode should be reactivated.



For activation, mark the box near these icons.

Configuring Automatism When Driving in Reverse

Several tractors can send a signal through the ISOBUS to all ISOBUS ECUs when the reverse gear is engaged. TRAIL-Control can then detect a reverse driving signal and react to it.

As a standard, TRAIL-Control stops working if a reverse driving signal is detected. In this case, the automatic mode remains activated, but the hydraulic valves are not being controlled.

You can configure how TRAIL-Control should react when a reverse driving signal is received.

To activate the automatism:

1. Switch to the "TRAIL-Control" screen:



or

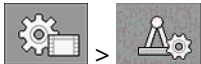

The "TRAIL-Control" screen appears.

2.  - Press.

The second page of "TRAIL-Control" appears.

An automatism is described on each line. On the left in the brackets, you can see the conditions under which a mechanism is executed. On the right, the effects.

3. To activate functions, set the check mark on the desired line. These functions will be explained in the following sections.

Reaction to the Reverse Driving Signal in Automatic Mode

If you are in automatic mode and the reverse signal is detected, the manual mode is activated. Most drivers prefer to steer the trailed implement manually when driving in reverse.



For activation, mark the boxes near these icons.

Reaction to the Reverse Driving Signal in Manual Mode

When the system is working in manual mode and the vehicle drives in reverse, the trailed implement can be centered.



Centering with reverse driving signal

Mode of Operation





As soon as the vehicle comes to a stop (speed = 0 km/h), the  icon appears on the screen (





for axle steering). If you drive in reverse in the next 10 seconds, the trailed implement will be centered. If you only drive in reverse after the 10 seconds have expired, nothing happens. This aims to prevent the trailed implement from being centered when parked vehicles are driven in reverse.

Important remarks:



When the  () icons appear, you can immediately steer the trailed implement manually.

If you press the  () or  () buttons during the automatic centering procedure, the centering will be aborted.

The centering procedure never takes longer than 8 seconds. If the trailed implement is not centered after 8 seconds, the centering procedure is aborted.

Several tractors send a reverse driving signal unexpectedly or without reason, even if they are standing still. To minimize the risks for the driver, the automatic centering can only be automatically activated in the first 10 seconds after the vehicle comes to a stop. If the vehicle has been standing for longer than 10 seconds and only then driven in reverse, automatic centering will not be performed.

Extension: DISTANCE- Control

- For Your Safety
- About DISTANCE-Control
- Mounting and Installation
- Basic Control Principles
- Configuring DISTANCE-Control
- Troubleshooting DISTANCE-Control

For Your Safety

Read the following safety instructions carefully before using the product for the first time.

- No one should approach the ultrasonic sensors when DISTANCE-Control is operating in automatic mode. When someone is approaching the sensor, the system can start to control the position of the boom. The boom can then hit other people and objects.
- DISTANCE-Control should therefore only be used during field work and in compliance with safety distances. If you are outside of the field, or if you are unable to comply with safety distances from persons and objects, set the system to manual mode.
- When installing, maintaining or calibrating the DISTANCE-Control II system, you must take all safety-related measures which are applicable to your personnel and the field sprayer.

Safety Mechanisms

The ECU software is provided with multiple safety mechanisms, which automatically deactivate the DISTANCE-Control system.

Every user and every fitter must know these safety mechanisms.

DANGER!

DEACTIVATED SAFETY MECHANISMS

SERIOUS BODILY INJURY OR MATERIAL DAMAGE

THE FIELD SPRAYER MANUFACTURERS AND FITTERS HAVE THE OPTION OF DEACTIVATING SOME SAFETY MECHANISMS SO THAT THE SYSTEM CAN SATISFY THE SPECIAL REQUIREMENTS OF THE FIELD SPRAYER. PTX TRIMBLE CANNOT SAY WHICH CHANGES TO THE CONFIGURATION A FIELD SPRAYER MANUFACTURER OR A FITTER CARRY OUT. REGARDING THE DEACTIVATION OF SAFETY MECHANISMS, THE PERSON AND THE MANUFACTURER THAT DEACTIVATE THE SYSTEMS BEAR SOLE RESPONSIBILITY FOR THIS.

FIND OUT WHETHER THE FIELD SPRAYER MANUFACTURER OR FITTER HAS DEACTIVATED SAFETY MECHANISMS.

The system is deactivated in the following cases:

- When the maximum permitted speed has been reached. By default the maximum speed is 15 km/h.
- When the user starts the calibration of DISTANCE-Control. However, bear in mind that the boom is automatically moved during several phases of the calibration.
- When an alarm message connected with DISTANCE-Control appears on the screen.
- When one of the following sensors sends a signal to the ECU:
 - Boom locking sensor
 - Boom pole sensor
 - "Boom in transport position" position sensor

Safety Distances

Obligations of the Field Sprayer Manufacturer

The safety distance must be specified by the field sprayer manufacturer and passed to the driver.

Obligations of the Driver

The field sprayer driver must always ensure that no person or object enters the hazard area. If this happens, the driver must set the DISTANCE-Control system to manual mode.

When DISTANCE-Control is automatically controlling the position and height of the boom, it only takes account of the distance of the ultrasonic sensors from the ground. Sloping can cause the outer end of the boom to be higher than the defined working height or boom raising height.

When working, ensure that you do not touch overhead power lines.

Always maintain a sufficient distance from power lines.

If working under power lines, set DISTANCE-Control to manual mode and control the position of the boom manually.

Intended Use

The DISTANCE-Control system serves to automatically guide the field sprayer boom. The purpose of the system is to support the operator of a field sprayer in maintaining an optimal distance from the plants.

DISTANCE-Control must only be installed on field sprayer booms. Do not use the system for any purposes other than those described here. Applications that are not expressly recommended by PTx Trimble will void any warranty claims.

About DISTANCE-Control

Mode of Operation

The DISTANCE-Control system supports the field sprayer driver in maintaining a constant distance of the boom to the ground.

The control types that the system can actuate are dependent on the type of field sprayer and on your configuration.

Possible Controls

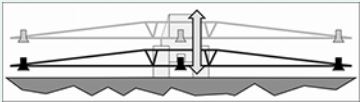
Type of Control	Purpose
 <p data-bbox="180 1881 505 1906">Lifting and lowering the boom</p>	<ul style="list-style-type: none"> <li data-bbox="578 1759 1089 1785">▪ To maintain a constant distance from the ground. <li data-bbox="578 1801 1422 1860">▪ To raise the boom above the crops on headlands to protect the crops when turning around. <li data-bbox="578 1877 1114 1902">▪ To set the optimum height before folding the boom.

Type of Control	Purpose
 <p data-bbox="248 401 440 426">Sloping the boom</p>	<ul style="list-style-type: none"> <li data-bbox="578 279 1192 304">To maintain a constant distance from the ground on slopes.

Mode of Operation

Thanks to the use of the sensors, the ECU always knows the height and slope of the boom. So it can adjust the position of the boom automatically.

To prevent the boom from touching the ground when turning (caused by centrifugal forces), the system can raise the boom before the turning maneuver. Two heights are defined in the system for this purpose:

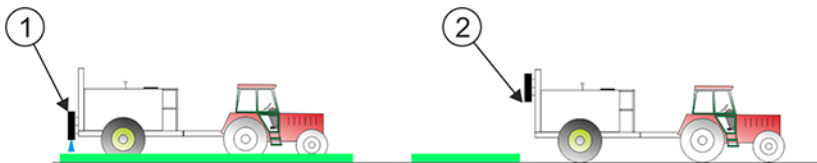

When spraying, the distance to the plants is too small

Item	Description
1	Working height Distance between the boom and the ground when at least one section is applying.
2	Boom raising height Distance by which the boom should be raised when turning. Is actuated when the sprayer is not applying.

System Overview

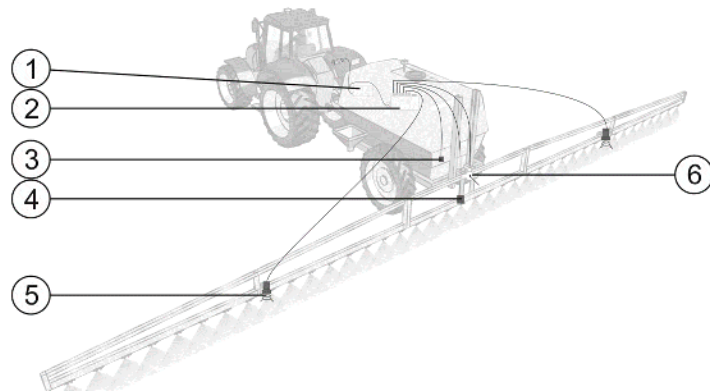

DISTANCE-Control - Overview of the components

Item	Description	Item	Description
1	ISOBUS ECU: SPRAYER-Controller MIDI	4	Boom slope sensor

Item	Description	Item	Description
2	Junction box	5	Ultrasonic sensor (2 pieces)
3	Sprayer slope sensor	6	Angle sensor (boom potentiometer)

Mounting and Installation

Boom Requirements

The electronically supported height guidance of the boom involves the interaction of electrics, sensors, hydraulics, pneumatics and mechanics.

The centrifugal forces must also not be neglected, which are caused by the movement and weight transfer of the field sprayer. These forces can only be considered to a limited extent, as they are difficult to measure.

It is therefore important that the system is only installed on field sprayers with a boom that fulfills several minimum requirements.

In this section, we will introduce a series of tests that will assist you in checking a boom.

If the boom does not achieve the desired results in one of the tests, you must either revise the structure of the boom or make changes to the hydraulic system.

Hydraulic System Requirements

- The same oil pressure and the same oil volume must always be present at all hydraulic valves. This must also be ensured when the engine speed fluctuates and when other valves are opened.
- There may not be any throttles in the hydraulic system for adjusting the oil pressure. The oil pressure is automatically controlled by the ECU.
- For the "Sloping" and "Tilting" functions, the system must be equipped with proportional valves. Note that the oil requirements depend on the size of the hydraulic cylinder. In most cases, valves with an oil flow of 5 to 15 l/min are sufficient.
- The proportional valves must be individually controlled without influencing each other. For example, it must be possible to simultaneously tilt up one wing while the other wing is tilted down.
- If no proportional valve is activated, the wings must remain in their position. Note that the gravitational force pulls the wings downwards. For this reason, it may be necessary to install a braking valve.
- It is possible to use one bypass valve for a maximum of two of these functions.
- The hydraulic system may not have any leaks. The boom must be able to remain in each position for a long time. The hydraulic cylinders may not yield even with high oil pressure.

Mechanics Requirements

For the system to work, the mechanical construction of the boom must be such that it reacts the same on the left and on the right.

Preparation for the test:

- For testing the mechanics, an ISOBUS ECU does not need to be installed.
- For some of the tests, the field sprayer must be standing on level ground, and for others, on a hillside.

Same range on both sides

Requirements: The maximum angle must be the same on the left and on the right.

1. Unfold the boom two meters above the ground.
2. Compare the maximum range of the boom on the left and right sides. To do so, slope the boom manually as far as possible on the left and then on the right.
 - The boom must reach the ground on both sides.
 - If the boom is not wide enough to reach the ground at this height, measure the maximum deflection on each side. The minimum distance to the ground should be the same on both sides.
 - There may not be any physical obstacles or boundaries in the movement area of the boom.

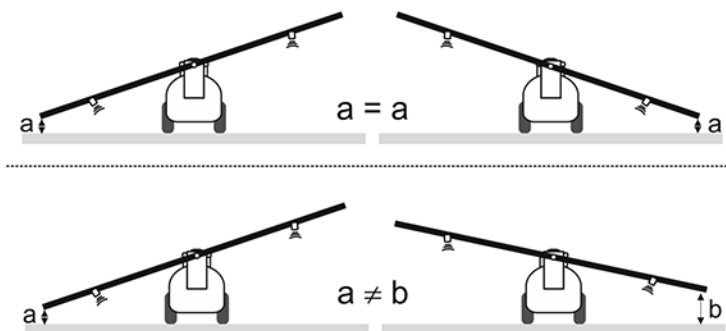

Top correct: Ranges on the left and right are equal. Bottom wrong: The maximum deflection on the left is bigger.

- The mechanical connection between the boom and the frame of the field sprayer must be the same on the left and right.
- When working on hillsides, the boom should preferably be able to reach the ground on each side and in every driving direction.

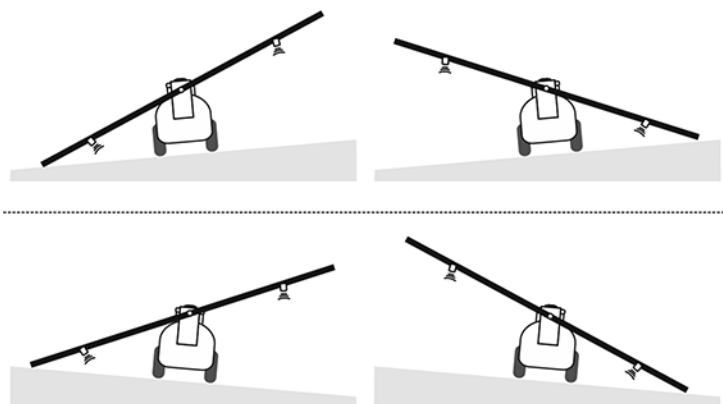

Correct: The boom can reach the ground even in extreme situations.

Swinging back

Requirements: The boom must swing back equally and evenly on both sides and regardless of the position of the field sprayer.

1. Unfold the boom two meters above the ground.
2. Position the boom horizontally using the hydraulic system (if available).
3. Press the boom manually as far as possible to one side.
4. Let the boom go from its maximum slope. Observe how it moves back on its own to the horizontal position.
5. Repeat the test for the other side.
6. Repeat the test on a hillside.
7. Compare the boom reaction:
 - The boom must move back to the horizontal position on its own.
 - Ideally, the boom should not overshoot when it reaches the horizontal position. It may only overshoot by a small distance.
 - Swinging back should look the same on the left and right.
 - Swinging back must look the same on level ground and on sloped terrain.

Steering Requirements

If the mechanics is OK, check how the boom position can be controlled using the ISOBUS ECU.



If the hydraulic system was only installed after the mechanical tests, repeat the mechanical tests. This way you can see right away if the newly installed hydraulic system changes anything with the mechanics.

For the following tests, a configured ISOBUS system provided by PTx Trimble must be installed on the field sprayer. You can control the boom using the terminal.

DISTANCE-Control is not required for these tests. If it is already activated, deactivate it or put it into manual mode.

Reliable and precise control



Requirements: The control of the boom position using the ISOBUS system must work precisely and reliably.

1. Unfold the boom two meters above the ground.
2. Move the boom using the function icons  and . Observe how precisely it can be moved under various conditions.
 - The boom must react to the actuation of the function icon within one second. Both when activating and when letting go of the function icon.
 - The boom must move evenly and with constant speed.
 - Check whether it can be moved reliably and precisely to a desired position.
 - The speed must be the same on the left and right.
 - Also on sloped terrain, it must be possible to slope the boom in every position that needs to be reached during operation. The hydraulic cylinders must also provide enough clearance to work on sloped terrain.

Precise length of the hydraulic cylinder when the boom is horizontal



Requirements: When the boom is horizontal, the sloping hydraulic cylinder must always have the same length – regardless of the direction from which the boom is moved.

1. Unfold the boom two meters above the ground.
2.  - Slope the boom as far as possible to the right.

3.  - Slope the boom back to the horizontal position. To avoid overshooting the horizontal position, move the boom in several short movements until it is exactly horizontal. If you overshoot the horizontal, repeat this test.
4. Check the position of the sloping hydraulic cylinder.
5.  - Slope the boom as far as possible to the left.
6.  - Slope the boom back to the horizontal position. To avoid overshooting the horizontal position, move the boom in several short movements until it is exactly horizontal. If you overshoot the horizontal, repeat this test.
7. Check the position of the sloping hydraulic cylinder.

In both cases, the hydraulic cylinder must be in the same position. The difference may not exceed 1% of the cylinder length.



Sloping speed

1. Unfold the boom two meters above the ground.
2.  - Slope the boom as far as possible to one side.
3.  - Measure the time required by the boom to reach the maximum slope on the other side. Also measure the time required by the hydraulic cylinder for the entire changeover.
4. Repeat the measurement for the other direction.

Optimal speed:

- Boom: 8 to 12 seconds

Optimal lifting speed

The lifting speed must be adjusted for the sloping speed. If you simultaneously lift the boom and slope it up on one side ( and ) , the end of the boom on the opposite side must remain exactly at one height.

Optimal speed when tilting

Requirement only applies for field sprayers with this function.

- The speed for tilting must be slower than for sloping, because otherwise the boom will oscillate.

Ultrasonic Sensors

Ultrasonic sensors measure the distance between the ultrasonic sensor and the ground below.

For proper functioning, the system requires two to four ultrasonic sensors. In certain cases, however, it is recommended to increase their number to five or six sensors.

Basic Installation Requirements

You should bear the following in mind when installing any ultrasonic sensor:

- The ultrasonic sensor's white membrane must face towards the ground.
- Ultrasonic sensors must be mounted on the front side of the boom in the direction of travel.
- Each ultrasonic sensor must have a clear view of the ground below. Only the ground below must be visible along its entire range of vision. Ensure that there are no machine components or spray cones between the ultrasonic sensor and the ground below.
- The ultrasonic sensors have a range of 3 meters. Mount the sensors such that they are not displaced further from the ground even in extreme boom positions.
- The sound must have a free path to the ground. Ensure that there are no machine components or spray cones between the ultrasonic sensor and the ground below.
- Ultrasonic sensors must be installed at least 35 cm above the nozzles. This is the size of the sensor's blind zone. The precise distance can differ on each model and must be determined and specified by the field sprayer manufacturer.

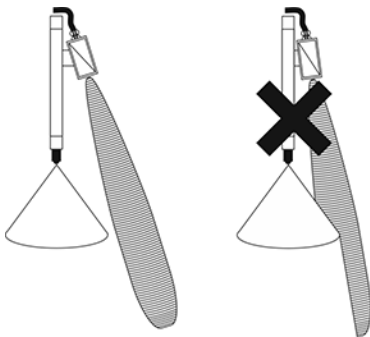

Left: The angle is big enough. Right: The angle is too small. The spray agent spray cone blocks the sound.

Installing the Ultrasonic Sensors on the Wings

Take note of the following when selecting the installation location:

- Install at least one ultrasonic sensor on each wing.

Position on the boom:

- The ultrasonic sensors on the left and right must be mounted as far out on the boom as possible. However, the distance to the outer end must be at least 2 meters.
- The maximum range of the ultrasonic sensors is 3 meters. Mount the sensors such that this distance to the ground is not exceeded during operation.
- The distance from the ultrasonic sensor to the center of the boom must be the same on each side.

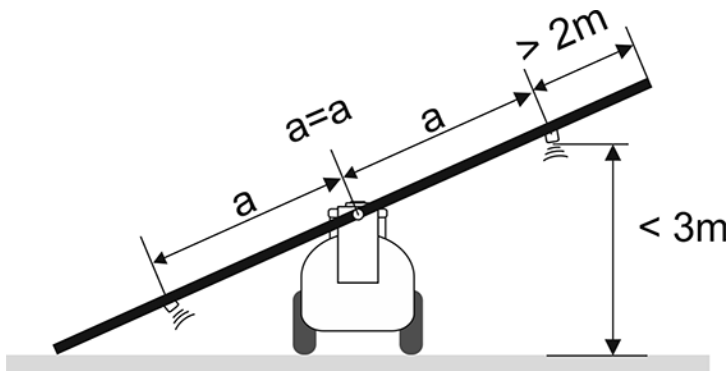

Angle:

- The ultrasonic sensor must face approx. 10° to 15° forward in the direction of travel and 10° to 15° towards the center of the boom.

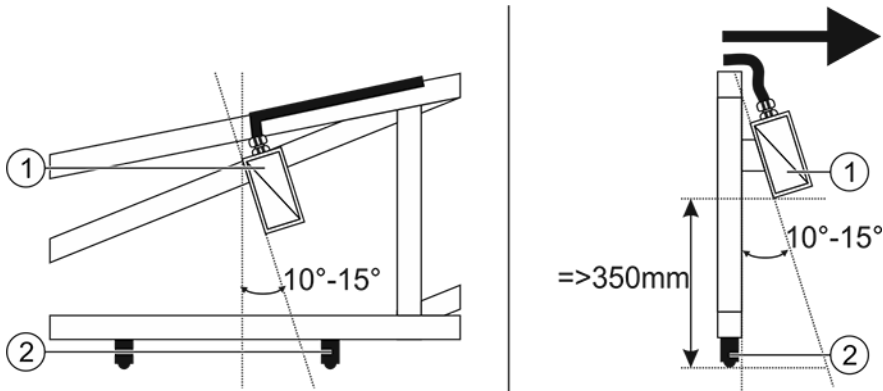

Ultrasonic sensor on the boom as seen from the front. The arrow indicates the direction of travel.

Item	Description	Item	Description
1	Ultrasonic sensor	2	Nozzle



Example: Ultrasonic sensor on the boom

Checking the Mounting Position

Using the ISOBUS ECU, you can check whether the ultrasonic sensors can exceed the maximum range.

Before you begin, make sure:

- The field sprayer is standing on a rough surface (gravel / grass surface etc.). Ground with a smooth surface, like asphalt or concrete, is unsuitable for this test.
- The boom is completely unfolded and horizontally aligned two meters above the ground.
- All sensors are connected.
- DISTANCE-Control has been calibrated.

1. Start the first calibration phase for DISTANCE-Control.

In the first phase, the distance from the ground measured on the left and on the right appears on the terminal.

2. Do not continue beyond the first calibration step.



3. - Slope the boom as far as possible on one side until it touches the ground.

The distance from each ultrasonic sensor to the ground is shown on the terminal. It keeps getting bigger on one side, and smaller on the other.

4. As soon as the boom touches the ground, check the distance shown on the screen for the upper sensor from the ground. The distance may not exceed 3 meters. Greater distances would cause frequent malfunctions during operation. If the distance is greater than three meters, mount the sensor more towards the center of the boom.
5. If an alarm message appears, continue reading further below about the possible causes.
6. Press ESC to exit the calibration window. If you exit the calibration window in a different way, the DISTANCE-Control system cannot be activated.

If the alarm message “No left ultrasonic signal” or “No right ultrasonic signal” appears before the boom touches the ground on one side, it can be due to the following reasons:

1. The upper ultrasonic sensor is outside of its range. In this case, you must check if you can change the mounting angle, and if this does not help, move the sensor more towards the center of the boom. In doing so, observe the specifications in these instructions.
2. While sloping the boom, the ultrasound was directed towards a smooth surface. For example, this can be a toolbox or a manhole cover.
3. Parts of the boom are obstructing the optimal path of the ultrasound. This reduces the maximum range of the sensor. The sensor seems to be working normally, it only loses the signal prematurely in certain positions.
4. The spray agent cone can also cause faults with the sensors. Especially if there is a tailwind.

Angle Sensors

Angle sensors measure the distance moved by a hydraulic cylinder. This enables DISTANCE-Control II to calculate the position of the boom.

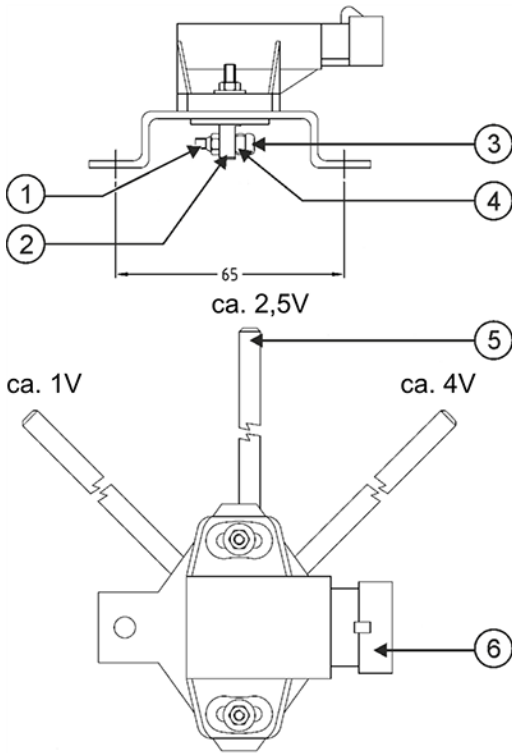

Item	Description	Item	Description
1	Lock nut	4	Sensor bar
2	Potentiometer shaft	5	Bar round material Ø6 (V2A)
3	4 screws	6	Sensor plug, always on the right side of the sensor bar

Angle sensors consist of a potentiometer (aka: poti) and a sensor bar. The movement of the bar causes the potentiometer shaft to rotate on its own axle. This changes the voltage in the potentiometer and the sensor can calculate the change in the angle.

Please find the angle sensor data on the data sheet which you will have received with the angle sensor.

As an alternative to angle sensors: Some field sprayer manufacturers replace angle sensors with special motion sensors which are integrated into the hydraulic cylinders. If you have hydraulic cylinders with integrated motion sensors, you do not need to install angle sensors.

There is no change to the operation of the software in this case.

Installing the Angle Sensors

Installation location

Install an angle sensor on each hydraulic cylinder which affects the following controls:

- Sloping the boom
- Tilting the boom upward or downward

You should note the following:

- The angle sensor must be installed such that it is not damaged by the movements of the boom.

Installation position

During installation, ensure that the angle sensor must measure the entire path of the hydraulic cylinder. In doing so, the path between maximum left and maximum right should be as big as possible.

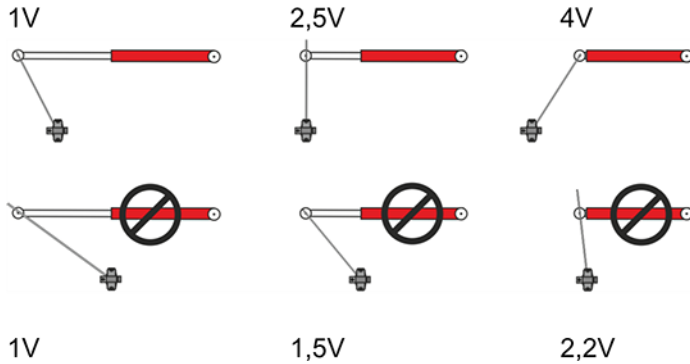

Top correct: There is a big difference in voltage when a hydraulic cylinder is completely extended and completely retracted. Bottom wrong: There is a very small difference in voltage between the extreme positions of the hydraulic cylinder.

- When the hydraulic cylinder is extended or retracted, the sensor bar of the angle sensor must also be moved.
- The bar must be attached such that the flat side of the potentiometer shaft (under the sensor) faces towards the sensor plug.
- The bar must be firmly installed without play.
- When the boom is horizontal, the potentiometer must be in the center position.
- Do not reuse loosened lock nuts.

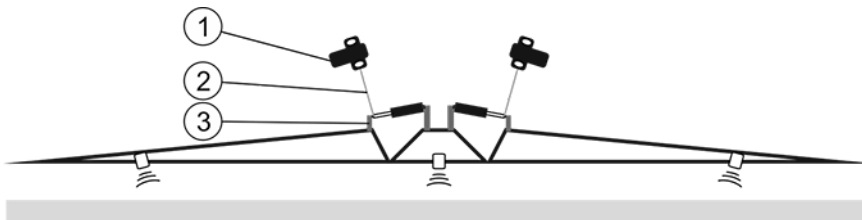

Angle sensors on the boom determine the angle when the boom is tilted upward or downward

Item	Description
1	Angle sensor (tilting)
2	Sensor bar of the angle sensor
3	Hydraulic cylinder which tilts the boom

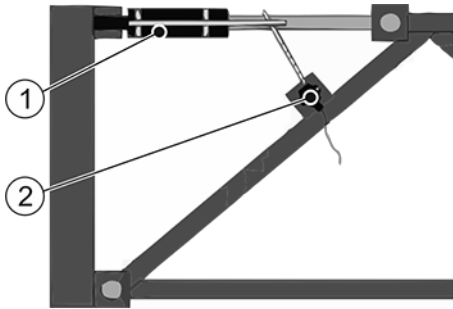

Angle sensor on hydraulic cylinder for DISTANCE-Control II

Item	Description
1	Hydraulic cylinder
2	Angle sensor

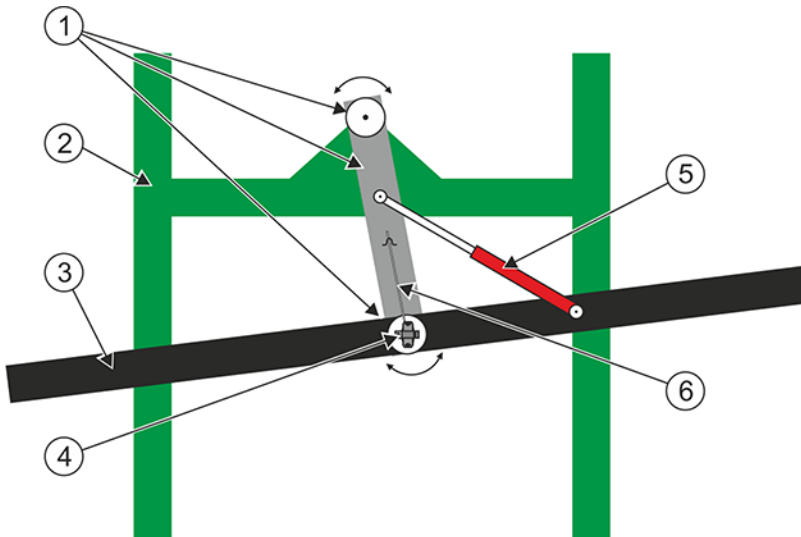

Boom potentiometer: The potentiometer of the angle sensor is only rotated when the hydraulic cylinder is extended or retracted.

Item	Description	Item	Description
1	Pendulum suspension	4	Angle sensor
2	Field sprayer frame	5	Hydraulic cylinder that is responsible for the sloping of the boom.
3	Boom	6	Sensor bar of the angle sensor

When extending and retracting the sloping hydraulic cylinder, the bar should rotate the potentiometer shaft. The sensor must therefore be installed such that the potentiometer only rotates when the hydraulic cylinder moves. The angle sensor must not be affected when other parts of the boom suspension move or oscillate.

During installation, ensure that when the boom is horizontal, the potentiometer must be in the centre position. The voltage must be ca. 2.5 V.

Calibration after installation

After each installation, the entire DISTANCE-Control system must be recalibrated.

Slope Sensors



Slope sensor

You must install up to two slope sensors:

- “Boom slope sensor”

This sensor determines the slope of the boom. Install it on the boom.

- “Sprayer slope sensor”

This sensor determines the slope of the entire field sprayer regardless of the boom position. Install it on the field sprayer frame.

This sensor is optional for field sprayers where the boom is set into motion when the field sprayer oscillates.

Installation Position

When determining the correct position, observe that:

- The sensor must be installed such that it does not vibrate during operation.
- After installation, the side with the sticker must be facing in or opposite to the driving direction.
- The cable must be facing downwards.

Basic Control Principles

Initial Start-up



Perform the following procedure during initial commissioning:

1. Start the terminal and the ECU.
2. Calibrate DISTANCE-Control.
3. Define the parameters “Working height” and “Boom raising height”.
4. Select the work mode.

Activating DISTANCE-Control and Switching to Manual Mode

The work screen of the ECU tells you what mode DISTANCE-Control is working in.

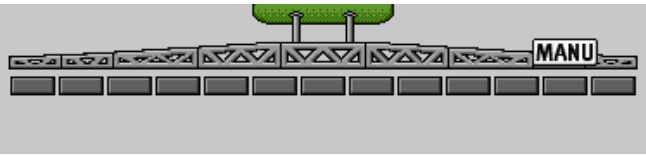
DISTANCE-Control working modes

Mode	Display in the work screen	Behavior
Manual mode		No automatic control
Automatic mode		The boom position is controlled automatically.

DANGER!

SERIOUS PHYSICAL INJURY OR DEATH DUE TO LOWERING THE BOOM

WHEN THE ECU CONTROLS THE POSITION OF THE BOOM AUTOMATICALLY, THIS CAN HIT ADJACENT PERSONS AND OBJECTS.

BEFORE ACTIVATING AUTOMATIC MODE:

- CHECK THAT NO ONE IS WITHIN RANGE OF THE BOOM!
- ENSURE THAT THERE ARE NO OBJECTS, POWER LINES OR TREES WITHIN RANGE OF THE BOOM!



Before you activate and deactivate the system, make sure the boom is unfolded.

1. Start the ECU.

After restarting, the system is always in manual mode.

2.  - On the work screen, press to activate automatic mode.

The icon **MANU** disappears:



DISTANCE-Control is activated in automatic mode.

Operating DISTANCE-Control While Working

CAUTION -

Damage due to boom lowering

If the DISTANCE-Control sensors are positioned outside of the crop, the boom will be lowered and sloped.

Before you exit the crop, stop the application:



The boom will be raised to the boom raised height.

Mode of Operation

During work, DISTANCE-Control works as follows:

- If at least one section is applying, the boom will be set to work height.
- If no section is applying, the boom will be set to the height saved in the parameter "Sprayer off height".

Requirements

You must fulfill the following preconditions before using DISTANCE-Control during work:

- DISTANCE-Control is calibrated.
- Working height is configured.
- Boom raising height is configured.

Configuring DISTANCE-Control

Activating DISTANCE-Control

To be able to use the system, it must first be activated and configured in the password-protected area.

Calibrating DISTANCE-Control

For each boom type unique data were determined. They are saved as master data in the ECU and cannot be changed by you.

You must however carry out an optimization by means of calibration.

The calibration records all parameters that vary according to production conditions or can change in the course of the field sprayer's operating time.

DISTANCE-Control can only function correctly when all of these points have been considered carefully and the calibration has been fully carried out.

NOTE –

For it to function correctly over the long term, regular maintenance of the moving parts is absolutely necessary. Changes in the mobility of the boom suspension can have serious negative effects on the regular behavior. Furthermore, it may not necessarily be corrected through recalibration.

Maintain the boom suspension regularly in accordance with the manufacturer's guidelines.

Calibration has the following purpose:

- Increasing the precision of DISTANCE-Control.
- Adjustment of the parameters to the user's field sprayer.
- Compensating for changes in boom behavior.

When should you calibrate?

You must perform the calibration in the following instances:

- During initial commissioning
- At the start of each season.
- When inaccuracies occur.
- When you have replaced or repaired the DISTANCE-Control components.

Mode of Operation

The calibration takes place in three phases:

- Phase 1: Prepare the height and slope of the boom for the calibration.
- Phase 2: Sloping the boom.
- Phase 3: Automatic calibration.

Although the individual phases are clearly separated from one another, they must be carried out after one another in a single run.

The machine may not be moved from its position in the interim.

If there are problems or the operator makes an error, the calibration will be broken off automatically and the old parameters restored.

DANGER!

ELECTRICAL SHOCK FROM CONTACT WITH HIGH-VOLTAGE LINES

DURING CALIBRATION, LONG BOOMS MAY TOUCH HIGH-VOLTAGE LINES.

ONLY CALIBRATE DISTANCE-CONTROL AT A SAFE DISTANCE FROM POWER LINES.

NOTE -

Distortion of counters

If anyone approaches the ultrasonic sensors during calibration, the values read by the counters will be distorted.

To calibrate DISTANCE-Control:

Phase 1: Prepare the Height and Slope of the Boom for the Calibration

Before you begin, make sure:

- The field sprayer is standing on level ground, without slopes.
- The spray liquid lines have the same weight on both sides of the boom. They either have to be empty or completely filled with water.
- There are no depressions in the ground under the ultrasonic sensors.
- The ground is not too smooth (no asphalt or concrete). The ultrasonic signal gets lost when the ground is too smooth.

- All moving parts of the boom suspension are sufficiently lubricated.
- The parameters of the field sprayer are correctly entered.

1. Switch to the "DISTANCE-Control" screen:

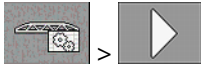

2.  >  - Start calibration.

The calibration procedure will be started.

3. Position the boom horizontally at a height of approx. 2m.

The distances between the left and right sensors and the ground are shown on the "DISTANCE Control" screen.

Depending on the boom status, the following messages can appear:

a. "Boom is now horizontal"

or

b. "Boom is not horizontal"

4.  - Press when the message "Boom is now horizontal" appears. Both distances are equal.

5. The setting will be saved.

Phase 1 of calibration has been completed.

Phase 2: Sloping the Boom

1.  - Start phase 2 of the calibration.

The following message appears:

"Push down the left boom and hold for 5s."

2. Manually press down the left end of the boom (seen in the driving direction) until the end of the boom is about 20 cm over the ground.

3. Hold the boom down in the position for about five to ten seconds. During this time, the ECU records the maximum slope.

- As soon as the ECU has recorded the maximum slope, the following message appears:

"Release the boom to horizontal position"

- If the message "Release the boom to horizontal position." does not appear, it means that the slope angle was too small at the beginning of calibration. Repeat the calibration as of phase 1. Raise the boom a little bit more so that the slope angle is bigger.
- If the message "Release the boom to horizontal position." does not appear, even though you performed all steps strictly according to the instructions, it can mean that the boom is still not sloped enough. In this case, cancel the calibration and then raise the boom a little bit higher. Then repeat the calibration.

4. Release the boom and let it swing back to the horizontal position. The boom may not swing back and forth for a long time. If it swings back and forth for a long time, it is too unstable and regulation using DISTANCE-Control is not possible.

The following message appears:

"Boom is now horizontal"



5.  - Press when the message "Boom is now horizontal" appears.

Phase 2 of calibration has been completed.

Phase 3: Automatic Calibration

DANGER!

AUTOMATICALLY MOVED BOOM

THE BOOM IS MOVED AUTOMATICALLY AND CAN CAUSE SERIOUS PERSONAL INJURY OR EVEN DEATH. IT CAN ALSO CAUSE MATERIAL DAMAGE OR DAMAGE ITSELF IF IT COLLIDES WITH SOMETHING.

THE FIELD SPRAYER MUST BE STANDING FAR ENOUGH FROM OTHER OBJECTS.

NOBODY MAY APPROACH THE FIELD SPRAYER DURING CALIBRATION.



- ABORT THE CALIBRATION IMMEDIATELY AS SOON AS SOMEONE APPROACHES THE FIELD SPRAYER.



1.  - Start phase 3 of the calibration.

The following message appears:

"Automatic calibration: Please wait..."

- The ECU begins with the automatic calibration of DISTANCE-Control.
- The boom will first be sloped to the left, and then to the right. Then it is moved to the horizontal position.
- The boom may not touch the ground in the process.
- If the boom is not properly set to the horizontal position at the end, it does not mean that the calibration has failed.

2. Observe the boom movements.

3. If something is not OK, then abort the procedure with .

All three steps then have to be repeated.

The calibration is successfully completed when the following message appears:

"Calibration finished. Please press OK."



4.  - Adopt the new calibration values.

5.  - Discard the calibration.

If the calibration was properly completed, DISTANCE-Control is ready for operation and can be activated

by pressing the  button on additional screen 1.

Configuring Working Height

Working height – the distance between the boom and the plants when at least one section is applying.

You can configure the working height in the following situations:

- When the field sprayer is standing still - before starting operation.
- When the field sprayer is moving - during operation.

Configuring the Working Height When the Field Sprayer is Standing Still

To adjust the working height when the field sprayer is standing still:

Before you begin, make sure:

- DISTANCE-Control is deactivated.
- The field sprayer is standing on the field. The boom is positioned over the plants.
- The field sprayer is not applying.

1. Adjust the boom to the desired working height.
2. Switch to the “DISTANCE-Control” screen:



3.  - Save the working height.

The working height will be saved.

Adjusting the Working Height During Operation

To adjust the working height during operation:

Before you begin, make sure:

- DISTANCE-Control is activated.
- All the ultrasonic sensors are positioned over the plants.
- At least one section is applying.

1. Switch to the “DISTANCE-Control” screen:



2. Use the function keys to set the boom to the desired height above the plants.
 - Each time the function key is pressed, the boom is moved.
 - The working height is saved as soon as you stop regulating the height.
 - The saved distance will be maintained by DISTANCE-Control during the application.

Configuring Boom Raising Height

Boom raised height - The distance between the boom and the plants when no sections are applying.

The set boom raising height appears as the "Sprayer off height" parameter.

When turning, the boom can become unbalanced and be sloped/slanted by centrifugal forces. In doing so, it can be damaged through ground contact and can damage the plants.

To prevent the boom from touching the ground or the plants when turning on the headland, the boom is raised as soon as the application is interrupted. The boom raising height determines how high it is raised.

You can configure the boom raising height in the following situations:

- When the field sprayer is standing still - before starting operation.
- When the field sprayer is moving - during operation.

Configuring the Boom Raised Height When the Field Sprayer is Standing Still

To adjust the boom raised height when the field sprayer is standing still:

Before you begin, make sure:

- DISTANCE-Control is deactivated.
- All the ultrasonic sensors are positioned over the plants.
- The field sprayer is not applying.

1. Adjust the boom to the desired boom raised height.
2. Switch to the "DISTANCE-Control" screen:



3.  - Save the boom raised height.

The boom raised height will be saved.

Adjusting the Boom Raised Height During Operation

To change the boom raised height during operation:

Before you begin, make sure:

- DISTANCE-Control is activated.
- The field sprayer is on the field. The boom is positioned over the plants.
- The field sprayer is not applying.

1. Switch to the "DISTANCE-Control" screen:



2. Use the function keys to set the boom to the desired height above the plants.
 - Each time the function key is pressed, the boom is moved.
 - The boom raised height is saved as soon as you stop regulating the height.

- The saved distance will be maintained by DISTANCE-Control as soon as you stop the application.

Selecting the Work Mode

The parameter “Work mode” allows you to set what DISTANCE-Control should regulate automatically.

To set the desired work mode:

1. Switch to the “DISTANCE-Control” screen:

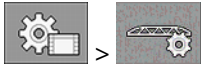

2.  - Press to set the desired work mode.

On the “Work mode” line, you can see the currently set work mode.

3.  - Deactivate DISTANCE-Control.

4.  - Activate DISTANCE-Control.

5. Restart the ECU.

The new work mode is activated and the boom will be regulated according to the new specifications.

Configuring the Chassis/Boom Factor

With the “Chassis/Boom factor”, you can set the friction value between the chassis of the vehicle and the boom.

To set the value:

1. Switch to the “DISTANCE-Control” screen:



2. Enter the desired value in the “Current setting” parameter. The higher the set value, the more movements are transmitted from the vehicle to the boom.

Configuring the Regulation Speed

As of software version 6.4p, the system offers the option of accelerating or decelerating the regulation.

“Regulation Factor” Parameter

With this parameter, you can set how fast the system should react to changes in the distance from the ground. The parameter may not be used to compensate for structural flaws.

Possible values:

- 3.0 – Minimum and default value – All background parameters that are determined during calibration are saved along with this value. This value gives the boom enough time to oscillate by itself into a stable position. In doing so, only gravity and the installed dampers are used.

Starting with this value, you can start optimizing the boom reaction and increase the regulation factor in small steps:

- The smaller and lighter the boom, the higher the regulation factor can be set.
- With large and heavy booms, you should not increase the regulation factor.
- 24.0 – maximum value – the system starts reacting very early to minimal changes in the boom position. It actuates the hydraulic valves right away. This can cause the movement of the boom to become turbulent. It starts “oscillating”.

With this setting, the entire system is subject to many great forces. This can reduce the service life of the boom suspension.

To use the regulation factor in the installation phase:

1. Set the “Regulation factor” parameter to 3.
2. Configure and calibrate all system components until boom operation is very stable.
3. If you want to increase the reaction speed, increase the regulation factor incrementally.
4. If you make changes to the construction, set the regulation factor back to 3 and repeat the last three steps of these instructions.

To set the regulation factor:

Before you begin, make sure the system has already been calibrated.

1. Switch to the “DISTANCE-Control” screen:



2. Set the “Regulation factor” parameter.

The value is adopted directly after entry and without restarting the system.

Configuring the (Minimum) Safety Height

On some field sprayer models, the “Safety height” parameter can help to prevent collisions of the boom with the ground.

Each time an ultrasonic sensor (left or right) goes below this height, the boom is automatically raised. This is especially helpful when one side of the boom swings down in an oscillating motion and cannot be set parallel to the ground in time.

Possible values:

- **OFF** – Function is deactivated.
- **Auto** – The ECU automatically calculates the optimum safety height for the boom.
- **Height in cm** – You can also manually enter a safety height between 40cm and 150cm – in increments of 10.

Troubleshooting DISTANCE-Control

Frequent Issues

Problem description	Measure
The control system is too slow.	<ul style="list-style-type: none"> • Calibrate the system • Adjust the reaction speeds in automatic mode.
The speed is too slow in manual mode.	<ul style="list-style-type: none"> • Adjusting reaction speed for manual operation
The control system oscillates.	<ul style="list-style-type: none"> • Check the control system tolerances. • Adjust the reaction speeds in automatic mode. • If slope centering is active, try switching this off to assess which control system is the cause.
Hydraulic valve/bypass valve does not actuate	<ul style="list-style-type: none"> • Check which ECU the valve is connected to. • Check the configuration of this ECU. • If necessary, redo the configuration with the PTx Trimble Configurator. • Sprayer configuration conditions are transferred from the DCII.
Automatic mode cannot be switched on	<ul style="list-style-type: none"> • A sensor is faulty. The corresponding error message with alarm screen should appear. • A sensor prevents automatic mode (folding sensor, work position sensor).
Automatic mode is suddenly exited (hand appears on the terminal)	<ul style="list-style-type: none"> • Check to see if the maximum speed has been exceeded. • Check to see if the user has attempted to fold or unfold the boom.
The control system regulates in reverse.	<ul style="list-style-type: none"> • Check that all hydraulic functions are connected in the right order. • Check whether the angle sensors are functioning correctly.
Certain control modes are not available.	<ul style="list-style-type: none"> • Faulty configuration. Repeat the configuration.
The joystick cannot be used during calibration.	<ul style="list-style-type: none"> • This is not a fault. The joystick is always deactivated during calibration.
The horizontal position can no longer be established during calibration. Calibration cannot be fully completed.	<ul style="list-style-type: none"> • Check the hydraulic system for leaks.

Alarm Messages

Alarm Messages During Operation

Text of Alarm Message	Cause
Defective angle sensor.	Defective angle sensor The signal voltage is outside of the valid range. Valid range: 0.5 V to 4.5 V
Sprayer Defective slope sensor.	The slope sensor installed on the frame of the field sprayer is defective or was not configured. The signal voltage is outside of the valid range. Valid range: 0.5 V to 4.5 V
Boom Defective slope sensor.	The slope sensor installed on the boom of the field sprayer is defective or was not configured. The signal voltage is outside of the valid range. Valid range: 0.5 V to 4.5 V
Defective right ultrasonic sensor.	The first echo of the ultrasonic sensor is not coming back. Sensor or cable is defective.
Defective left ultrasonic sensor.	The first echo of the ultrasonic sensor is not coming back. Sensor or cable is defective.
Error in the ultrasonic sensor cabling.	The cabling of the ultrasonic sensor is faulty.
Sensors are disturbed.	Short signal interruption with all sensors. An actuator might be connected to the sensor ground (GNDE) in the junction box.
Defective height angle sensor.	Angle sensor that measures the height of the lift pole is defective. This error message only appears on a few field sprayers that have manufacturer-specific configuration.
The speed is too high.	Appears when the forward speed is higher than the maximum permitted speed for the field sprayer model. The TRAIL-Control and DISTANCE-Control systems will then automatically be set to manual mode.

Alarm Messages During Calibration

Text of Alarm Message	Cause
No right ultrasonic signal.	There is no echo coming back for more than 50% of the trigger impulses.
No left ultrasonic signal.	There is no echo coming back for more than 50% of the trigger impulses.
The slope angle sensor is not correctly installed.	The signal voltage is outside of the valid range. Valid range: 0.5 V to 4.5 V
The drawbar angle sensor is not correctly installed.	The signal voltage is outside of the valid range. Valid range: 0.5 V to 4.5 V
The ultrasonic sensors are not correctly installed.	The sensors are connected inversely. (Left and right were inverted in the junction box)

Text of Alarm Message	Cause
No slope sensor signal.	In the second calibration step, the slope sensor did not detect a change in the signal.
No angle sensor signal.	In the third calibration step, the angle sensor did not detect a change in the signal.
Outputs are swapped.	The hydraulic valves were connected wrong.
Sensors are disturbed.	Short signal interruption with all sensors

System Troubleshooting

If the system is not working satisfactorily, you can try to find the cause systematically. Check for the following causes successively.

System	Troubleshooting
Boom	Ensure that the boom fulfills all of the requirements.
Installation and status of the ultrasonic sensors	Ensure that the ultrasonic sensors are not damaged, and that they are installed correctly and firmly.
Mounting position of the slope sensors	Ensure that the both slope sensors are correctly mounted.
Connection of sensors	<p>Before you begin, make sure:</p> <ul style="list-style-type: none"> The ECU is switched on. DISTANCE-Control is in manual mode. <ol style="list-style-type: none"> Disconnect the individual sensors from the extension cable. An alarm message appears on the terminal, which is specific for each type of sensor. Check whether the correct alarm message appears for each sensor. If, for example, the alarm message "Defective right ultrasonic sensor" appears when disconnecting the slope sensor, both sensors might be connected wrong.
Status of the terminals in the junction box	<ol style="list-style-type: none"> Ensure that the junction box and the terminals inside are dry, clean and free of corrosion. Ensure that the connecting wires in the screw terminals (ultrasonic sensors) are always covered with cable wire end sleeves. Connecting wires in the green terminal block may not have wire end sleeves. Ensure that only sensors are connected to the 12VE and GNDE sensor voltage supply, and that only actuators are connected to the 12VL and GNDL power voltage supply. The sensors react very sensitively to fluctuations in the power supply. If an actuator is connected to the sensor power supply, there may be faults with the sensors when it is activated. For this reason, no exceptions are allowed. Ensure that the vehicle chassis was not used for the connection of the auxiliary ground. This can also cause faults with the sensors.

System	Troubleshooting
Measuring the signal voltage	<p>Before you begin, make sure:</p> <ul style="list-style-type: none"> The ECU is switched on. DISTANCE-Control is in manual mode. <ol style="list-style-type: none"> Position the boom horizontally. Both the slope sensor and the angle sensor are in centre position. In the junction box, measure the signal voltage of the slope sensor and of the angle sensor. Measure between white (ws) = 0VE (GNDE) and green (gn) = signal. The voltage must be 2.5V. In doing so, do not use the vehicle chassis as a ground.
Recalibrate the boom	<ol style="list-style-type: none"> Recalibrate the system. NOTICE! You must absolutely ensure that the boom is not moved back manually to the centre position during the second calibration step.

Finding the Source of a Short Circuit

If the ECU reports the failure of several sensors at the same time, it is an indication for a short circuit - for example, due to a crushed cable for a sensor.

As soon as a short circuit is detected, the ECU switches off the power supply. This is why all of the sensors that are connected to the switched-off power source fail at the same time.

When the short circuit has been fixed, it only takes a few seconds for the ECU to activate the power supply.

Angle and slope sensors are supplied by a power source, possibly together with other sensors, such as the wheel sensor, gyroscope, or flow meter (depending on the system).

Because of the higher power requirement, the ultrasonic sensors have a separate power supply. See section: Ultrasonic sensors

To find and fix the cause of a short circuit:

- Open the junction box.
- Disconnect all of the affected sensors successively from the power supply. Each time you disconnect a sensor, measure the power supply in the junction box with a multimeter. Measure between the terminals 0V and 12V.
- Disconnect the sensors successively until the power is back on. The sensor with which the power supply was reactivated when it was disconnected, is faulty.
- Replace the cable or the sensor.
- Reconnect the sensor in the junction box.

Extension: DISTANCE-Control II

- For Your Safety
- About DISTANCE-Control II
- Mounting and Installation
- Basic Control Principles
- Operating DISTANCE-Control II on the Field
- Configuring DISTANCE-Control II
- Using the Password-Protected Area for Configuration
- Troubleshooting DISTANCE-Control

For Your Safety

Read the following safety instructions carefully before using the product for the first time.

- No one should approach the ultrasonic sensors when DISTANCE-Control is operating in automatic mode. When someone is approaching the sensor, the system can start to control the position of the boom. The boom can then hit other people and objects.
- DISTANCE-Control should therefore only be used during field work and in compliance with safety distances. If you are outside of the field, or if you are unable to comply with safety distances from persons and objects, set the system to manual mode.
- When installing, maintaining or calibrating the DISTANCE-Control II system, you must take all safety-related measures which are applicable to your personnel and the field sprayer.

Safety Mechanisms

The ECU software is provided with multiple safety mechanisms, which automatically deactivate the DISTANCE-Control system.

Every user and every fitter must know these safety mechanisms.

DISTANCE-Control is deactivated and set to manual mode in the following events:

- If the user performs a function in connection with the boom:
 - Lifting or lowering the boom
 - Sloping or tilting the boom
 - Folding the boom
- If one of the following sensors on the field sprayer sends a signal:
 - "Boom locked" position sensor
 - "Boom unlocked" position sensor
 - Boom top height sensor
 - "Boom in transport position" position sensor
 - "Boom at folding height" position sensor
 - "Critical boom height" position sensor

Whether these sensors are installed on the field sprayer is dependent on the model of the field sprayer. These are not required for DISTANCE-Control.

- If the field sprayer is moving faster than the maximum speed. The maximum speed will be specified by the field sprayer manufacturer when configuring the ECU.
- After restarting the ECU.

Safety Distances

Obligations of the Field Sprayer Manufacturer

The safety distance must be specified by the field sprayer manufacturer and passed to the driver.

Obligations of the Driver

The field sprayer driver must always ensure that no person or object enters the hazard area. If this happens, the driver must set the DISTANCE-Control system to manual mode.

When DISTANCE-Control is automatically controlling the position and height of the boom, it only takes account of the distance of the ultrasonic sensors from the ground. Sloping can cause the outer end of the boom to be higher than the defined working height or boom raising height.

When working, ensure that you do not touch overhead power lines.

Always maintain a sufficient distance from power lines.

If working under power lines, set DISTANCE-Control to manual mode and control the position of the boom manually.

Intended Use

The DISTANCE-Control system serves to automatically guide the field sprayer boom. The purpose of the system is to support the operator of a field sprayer in maintaining an optimal distance from the plants.

DISTANCE-Control must only be installed on field sprayer booms. Do not use the system for any purposes other than those described here. Applications that are not expressly recommended by PTx Trimble will void any warranty claims.

About DISTANCE-Control II

System Functions

The DISTANCE-Control system supports the field sprayer driver in maintaining a constant distance of the boom to the ground.

The control types that the system can actuate are dependent on the type of field sprayer and on your configuration.

Possible Controls

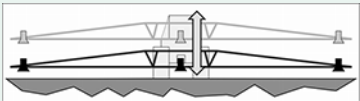
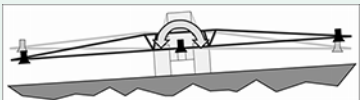
Type of Control	Purpose
 <p>Lifting and lowering the boom</p>	<ul style="list-style-type: none"> To maintain a constant distance from the ground. To raise the boom above the crops on headlands to protect the crops when turning around. To set the optimum height before folding the boom.
 <p>Sloping the boom</p>	<ul style="list-style-type: none"> To maintain a constant distance from the ground on slopes.

System Overview

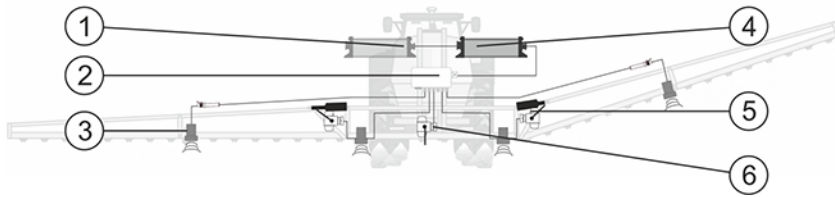

ECUs and sensors

Item	Description	Item	Description
1	ISOBUS ECU: SPRAYER-Controller MIDI	4	DISTANCE-Control II ECU
2	Junction box	5	Angle sensor for measuring the tilting
3	Ultrasonic sensor	6	Angle sensor for measuring the sloping of the boom (boom potentiometer)

Mounting and Installation

Boom Requirements

The electronically supported height guidance of the boom involves the interaction of electrics, sensorics, hydraulics, pneumatics and mechanics.

The centrifugal forces must also not be neglected, which are caused by the movement and weight transfer of the field sprayer. These forces can only be considered to a limited extent, as they are difficult to measure.

It is therefore important that the system is only installed on field sprayers with a boom that fulfills several minimum requirements.

In this section, we will introduce a series of tests that will assist you in checking a boom.

If the boom does not achieve the desired results in one of the tests, you must either revise the structure of the boom or make changes to the hydraulic system.

Hydraulic System Requirements

- The same oil pressure and the same oil volume must always be present at all hydraulic valves. This must also be ensured when the engine speed fluctuates and when other valves are opened.
- There may not be any throttles in the hydraulic system for adjusting the oil pressure. The oil pressure is automatically controlled by the ECU.
- For the "Sloping" and "Tilting" functions, the system must be equipped with proportional valves. Note that the oil requirements depend on the size of the hydraulic cylinder. In most cases, valves with an oil flow of 5 to 15 l/min are sufficient.
- The proportional valves must be individually controlled without influencing each other. For example, it must be possible to simultaneously tilt up one wing while the other wing is tilted down.

- If no proportional valve is activated, the wings must remain in their position. Note that the gravitational force pulls the wings downwards. For this reason, it may be necessary to install a braking valve.
- It is possible to use one bypass valve for a maximum of two of these functions.
- The hydraulic system may not have any leaks. The boom must be able to remain in each position for a long time. The hydraulic cylinders may not yield even with high oil pressure.

Mechanics Requirements

For the system to work, the mechanical construction of the boom must be such that it reacts the same on the left and on the right.

Preparation for the test:

- For testing the mechanics, an ISOBUS ECU does not need to be installed.
- For some of the tests, the field sprayer must be standing on level ground, and for others, on a hillside.

Same range on both sides

Requirements: The maximum angle must be the same on the left and on the right.

1. Unfold the boom two meters above the ground.
2. Compare the maximum range of the boom on the left and right sides. To do so, slope the boom manually as far as possible on the left and then on the right.
 - The boom must reach the ground on both sides.
 - If the boom is not wide enough to reach the ground at this height, measure the maximum deflection on each side. The minimum distance to the ground should be the same on both sides.
 - There may not be any physical obstacles or boundaries in the movement area of the boom.

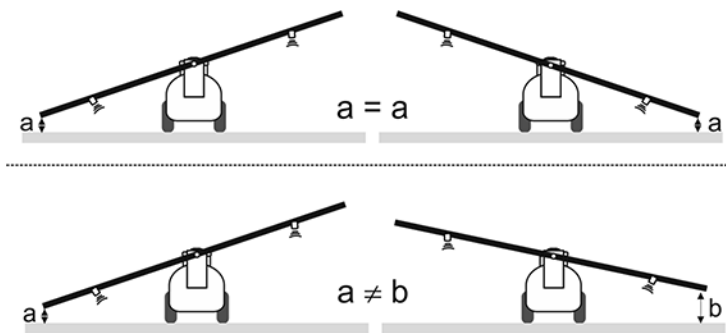

Top correct: Ranges on the left and right are equal. Bottom wrong: The maximum deflection on the left is bigger.

- The mechanical connection between the boom and the frame of the field sprayer must be the same on the left and right.
- When working on hillsides, the boom should preferably be able to reach the ground on each side and in every driving direction.

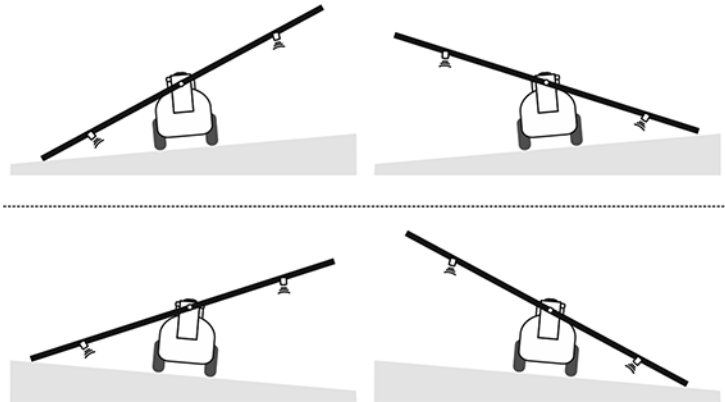

Correct: The boom can reach the ground even in extreme situations.

Swinging back

Requirements: The boom must swing back equally and evenly on both sides and regardless of the position of the field sprayer.

1. Unfold the boom two meters above the ground.
2. Position the boom horizontally using the hydraulic system (if available).
3. Press the boom manually as far as possible to one side.
4. Let the boom go from its maximum slope. Observe how it moves back on its own to the horizontal position.
5. Repeat the test for the other side.
6. Repeat the test on a hillside.
7. Compare the boom reaction:
 - The boom must move back to the horizontal position on its own.
 - Ideally, the boom should not overshoot when it reaches the horizontal position. It may only overshoot by a small distance.
 - Swinging back should look the same on the left and right.
 - Swinging back must look the same on level ground and on sloped terrain.

Steering Requirements

If the mechanics is OK, check how the boom position can be controlled using the ISOBUS ECU.



If the hydraulic system was only installed after the mechanical tests, repeat the mechanical tests. This way you can see right away if the newly installed hydraulic system changes anything with the mechanics.

For the following tests, a configured ISOBUS system provided by PTx Trimble must be installed on the field sprayer. You can control the boom using the terminal.

DISTANCE-Control is not required for these tests. If it is already activated, deactivate it or put it into manual mode.





Reliable and precise control

Requirements: The control of the boom position using the ISOBUS system must work precisely and reliably.

1. Unfold the boom two meters above the ground.
2. Move the boom using the function icons  and . Observe how precisely it can be moved under various conditions.
 - The boom must react to the actuation of the function icon within one second. Both when activating and when letting go of the function icon.
 - The boom must move evenly and with constant speed.
 - Check whether it can be moved reliably and precisely to a desired position.
 - The speed must be the same on the left and right.
 - Also on sloped terrain, it must be possible to slope the boom in every position that needs to be reached during operation. The hydraulic cylinders must also provide enough clearance to work on sloped terrain.

Precise length of the hydraulic cylinder when the boom is horizontal

Requirements: When the boom is horizontal, the sloping hydraulic cylinder must always have the same length – regardless of the direction from which the boom is moved.

1. Unfold the boom two meters above the ground.
2.  - Slope the boom as far as possible to the right.
3.  - Slope the boom back to the horizontal position. To avoid overshooting the horizontal position, move the boom in several short movements until it is exactly horizontal. If you overshoot the horizontal, repeat this test.
4. Check the position of the sloping hydraulic cylinder.
5.  - Slope the boom as far as possible to the left.
6.  - Slope the boom back to the horizontal position. To avoid overshooting the horizontal position, move the boom in several short movements until it is exactly horizontal. If you overshoot the horizontal, repeat this test.
7. Check the position of the sloping hydraulic cylinder.

In both cases, the hydraulic cylinder must be in the same position. The difference may not exceed 1% of the cylinder length.

Ultrasonic Sensors

Ultrasonic sensors measure the distance between the ultrasonic sensor and the ground below.

For proper functioning, the system requires two to four ultrasonic sensors. In certain cases, however, it is recommended to increase their number to five or six sensors.

Basic Installation Requirements

You should bear the following in mind when installing any ultrasonic sensor:

- The ultrasonic sensor's white membrane must face towards the ground.
- Ultrasonic sensors must be mounted on the front side of the boom in the direction of travel.

- Each ultrasonic sensor must have a clear view of the ground below. Only the ground below must be visible along its entire range of vision. Ensure that there are no machine components or spray cones between the ultrasonic sensor and the ground below.
- The ultrasonic sensors have a range of 3 metres. Mount the sensors such that they are not displaced further from the ground even in extreme boom positions.
- The sound must have a free path to the ground. Ensure that there are no machine components or spray cones between the ultrasonic sensor and the ground below.
- Ultrasonic sensors must be installed at least 35 cm above the nozzles. This is the size of the sensor's blind zone. The precise distance can differ on each model and must be determined and specified by the field sprayer manufacturer.

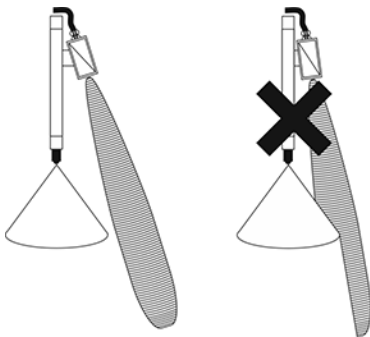

Left: The angle is big enough. Right: The angle is too small. The spray agent spray cone blocks the sound.

Installing the Ultrasonic Sensors on the Wings

Take note of the following when selecting the installation location:

- Install at least one ultrasonic sensor on each wing.

Position on the boom:

- The ultrasonic sensors on the left and right must be mounted as far out on the boom as possible. However, the distance to the outer end must be at least 2 meters.
- The maximum range of the ultrasonic sensors is 3 meters. Mount the sensors such that this distance to the ground is not exceeded during operation.
- The distance from the ultrasonic sensor to the center of the boom must be the same on each side.

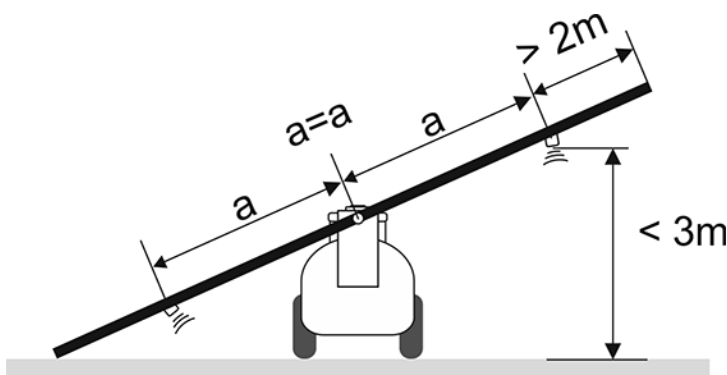

Angle:

- The ultrasonic sensor must face approx. 10° to 15° forward in the direction of travel and 10° to 15° towards the center of the boom.

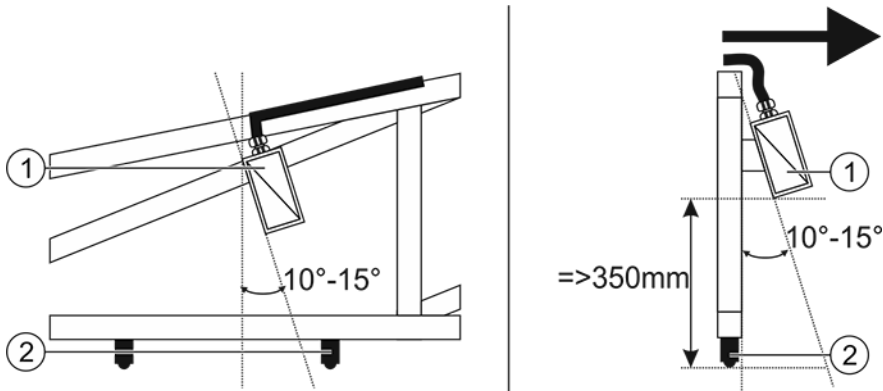

Ultrasonic sensor on the boom as seen from the front. The arrow indicates the direction of travel.

Item	Description	Item	Description
1	Ultrasonic sensor	2	Nozzle



Example: Ultrasonic sensor on the boom

Additional Sensors for the Wings

In some situations, one ultrasonic sensor is not enough to reliably measure the height of the wings:

- In crops planted on ridges (potato, asparagus);
- If the plants in row crops are still small;
- With certain tramline spacings;
- If the plants are growing very unevenly.

In these cases, you can install a second ultrasonic sensor on each wing. You have to use an adapted connector cable to make the connections.

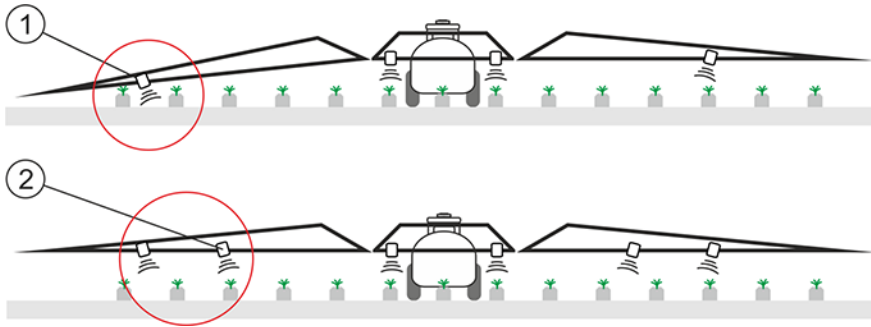

If the sensor regularly scans the ground between the plants, a second sensor must be installed.

Item	Description
1	One sensor is positioned between the potato rows.
2	The second sensor is installed so that one of the two sensors is always over the plants.

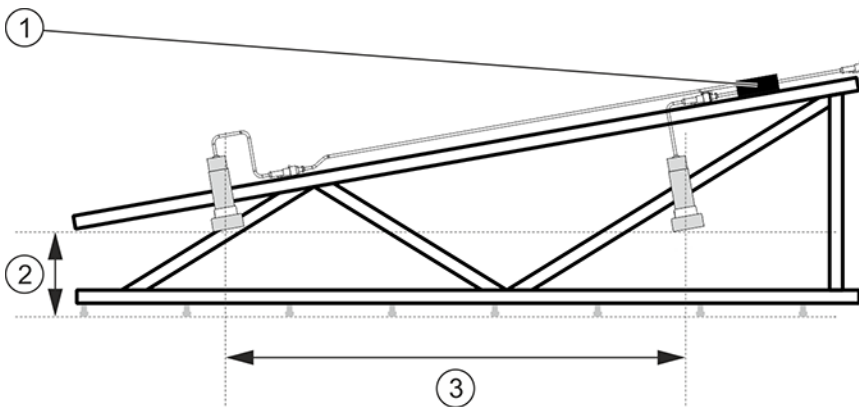

Two ultrasonic sensors on one wing

Item	Description
1	Y-cable to connect two ultrasonic sensors.
2	The distance to the ground (or nozzles) must be the same for both sensors.
3	Minimum distance between the sensors: 160 cm The maximum distance depends on the cable length. Available versions: 2 m - 31303052 4 m - 31303053 6 m - 3130305300

Installing Ultrasonic Sensors on the Center Section of the Boom

The ultrasonic sensors at the center of the boom measure the boom height, to be able to accurately reach the working height and the boom raising height.

You need at least one ultrasonic sensor on the center section of the boom. If it is very wide, you can install two ultrasonic sensors on the outer ends of the center section of the boom.

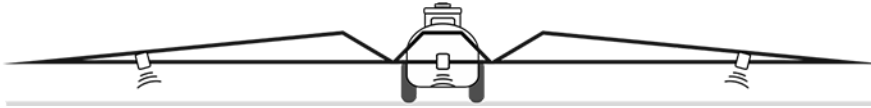

One ultrasonic sensor on the center section of the boom



Two ultrasonic sensors on the center section of the boom

Take note of the following when selecting the installation location:

- The ultrasonic sensor must face approximately 10° to 15° forward in the driving direction.
- The ultrasonic sensor should not face towards the side.
- The ultrasonic sensor may not scan the track. In the track, the distance to the sensor is much bigger than in the crops.

Checking the Ultrasonic Sensors

Check that the ultrasonic sensors are correctly connected as follows:

- The field sprayer is ready for use.
- The ultrasonic sensors are connected.
- DISTANCE-Control II is in manual mode.
- The tank is filled with clear water.

1. Open the “System Data” screen on DISTANCE-Control II:



The following screen appears:

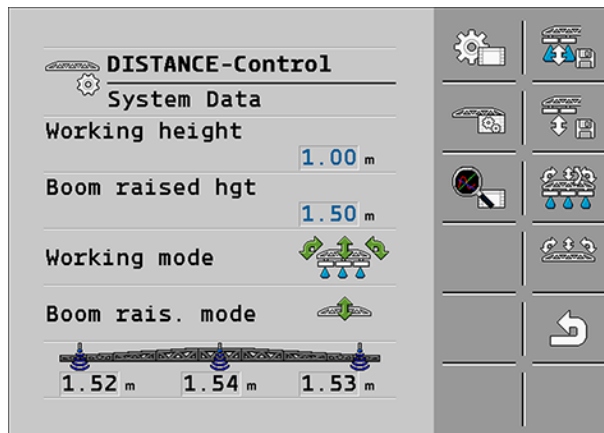

You can see the distance to the ground below, as read by the ultrasonic sensors, in the lower part of the screen.

2. Move the boom. Use the joystick to do this.
3. Check whether the distances on the display screen change after the movement. If they do, the sensors are functioning correctly.

4. Check whether the ultrasonic sensors are affected by the spray cones.
5. Start application.
6. Check whether the distances on the display screen change once the application has started. If they do, the ultrasonic sensors may be incorrectly installed and are being disturbed by the water spray.

Angle Sensors

Angle sensors measure the distance moved by a hydraulic cylinder. This enables DISTANCE-Control II to calculate the position of the boom.

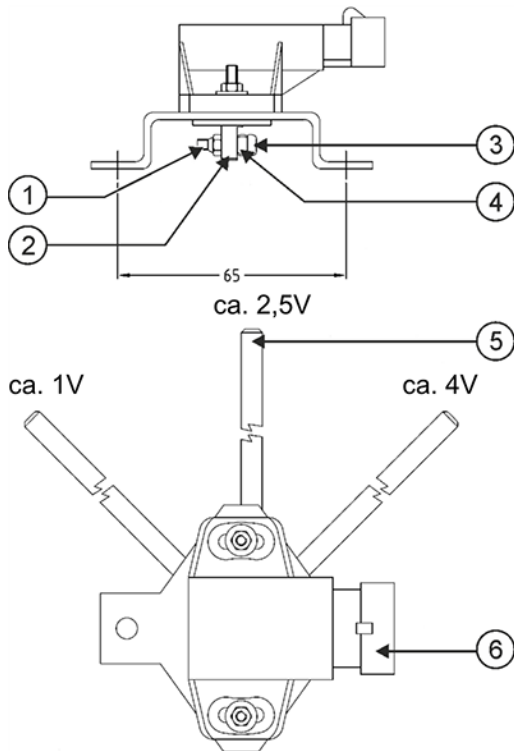

Item	Description	Item	Description
1	Lock nut	4	Sensor bar
2	Potentiometer shaft	5	Bar round material Ø6 (V2A)
3	4 screws	6	Sensor plug, always on the right side of the sensor bar

Angle sensors consist of a potentiometer (aka: poti) and a sensor bar. The movement of the bar causes the potentiometer shaft to rotate on its own axle. This changes the voltage in the potentiometer and the sensor can calculate the change in the angle.

Please find the angle sensor data on the data sheet which you will have received with the angle sensor.

As an alternative to angle sensors: Some field sprayer manufacturers replace angle sensors with special motion sensors which are integrated into the hydraulic cylinders. If you have hydraulic cylinders with integrated motion sensors, you do not need to install angle sensors.

There is no change to the operation of the software in this case.

Installing the Angle Sensors

Installation location

Install an angle sensor on each hydraulic cylinder which affects the following controls:

- Sloping the boom
- Tilting the boom upward or downward

You should note the following:

- The angle sensor must be installed such that it is not damaged by the movements of the boom.

Installation position

During installation, ensure that the angle sensor must measure the entire path of the hydraulic cylinder. In doing so, the path between maximum left and maximum right should be as big as possible.

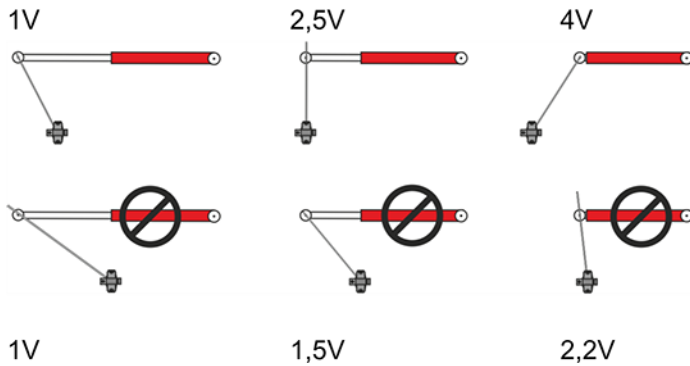

Top correct: There is a big difference in voltage when a hydraulic cylinder is completely extended and completely retracted. Bottom wrong: There is a very small difference in voltage between the extreme positions of the hydraulic cylinder.

- When the hydraulic cylinder is extended or retracted, the sensor bar of the angle sensor must also be moved.
- The bar must be attached such that the flat side of the potentiometer shaft (under the sensor) faces towards the sensor plug.
- The bar must be firmly installed without play.
- When the boom is horizontal, the potentiometer must be in the center position.
- Do not reuse loosened lock nuts.

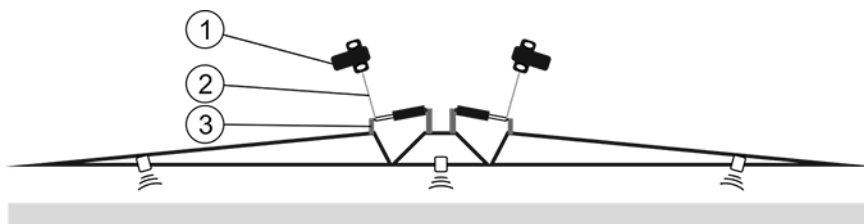

Angle sensors on the boom determine the angle when the boom is tilted upward or downward

Item	Description
1	Angle sensor (tilting)

Item	Description
2	Sensor bar of the angle sensor
3	Hydraulic cylinder which tilts the boom

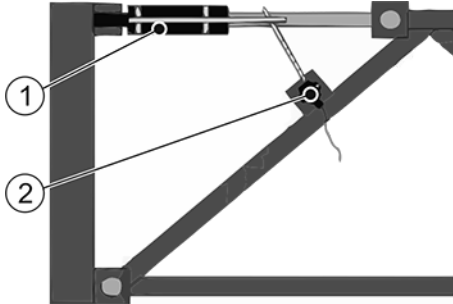

Angle sensor on hydraulic cylinder for DISTANCE-Control II

Item	Description
1	Hydraulic cylinder
2	Angle sensor

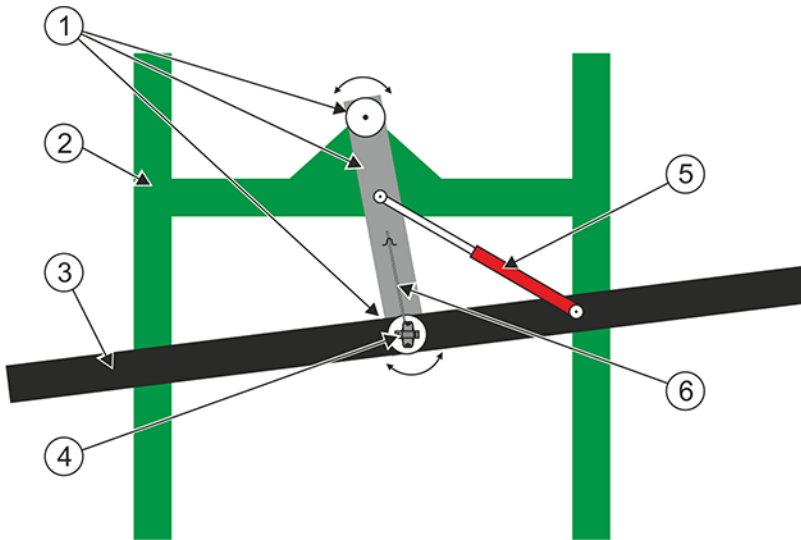

Boom potentiometer: The potentiometer of the angle sensor is only rotated when the hydraulic cylinder is extended or retracted.

Item	Description	Item	Description
1	Pendulum suspension	4	Angle sensor
2	Field sprayer frame	5	Hydraulic cylinder that is responsible for the sloping of the boom.
3	Boom	6	Sensor bar of the angle sensor

When extending and retracting the sloping hydraulic cylinder, the bar should rotate the potentiometer shaft. The sensor must therefore be installed such that the potentiometer only rotates when the hydraulic cylinder moves. The angle sensor must not be affected when other parts of the boom suspension move or oscillate.

During installation, ensure that when the boom is horizontal, the potentiometer must be in the center position. The voltage must be ca. 2.5 V.

Calibration after installation

After each installation, the entire DISTANCE-Control system must be recalibrated.

Checking the Angle Sensors

This is how you check if the angle sensors are functioning correctly:

1. Open the "Diagnostic" screen:



The following screen appears:

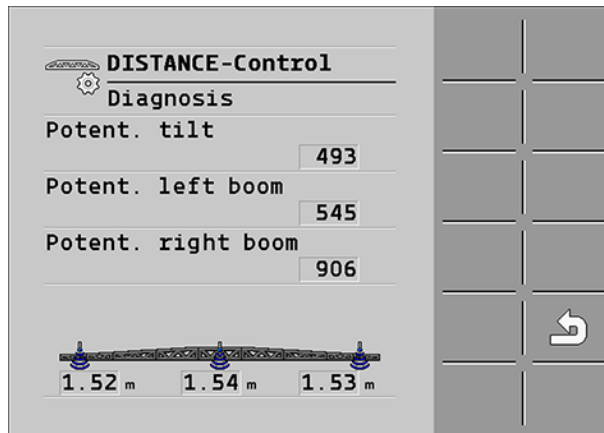



The screen shows values which are read by the potentiometers (Poti) of the connected angle sensors. These values must change when the wings are moved.

2.  or  - Slope the boom.

The "Potent. tilt" value must change.

3.  or  - Tilt the left wing up and down.

The value "Potent. left wing" must change. The value must increase when lifting, and decrease when lowering. Otherwise, the sensor is installed in the wrong direction.

4.  or  - Tilt the right wing up and down.

The value "Potent. right wing" must change. The value must increase when lifting, and decrease when lowering. Otherwise, the sensor is installed in the wrong direction.

Basic Control Principles

Initial Start-up

Perform the following procedure during initial commissioning:

1. Start the ECU.
2. Check if the ultrasonic sensors are functioning correctly.
3. Check if the angle sensors are functioning correctly.
4. Calibrate the DISTANCE-Control II system.
5. Define the "Working height" and "Boom raising height" parameters.
6. Define the "Working mode" and "Boom rais. mode" parameters.

Starting DISTANCE-Control II

You can the system in the following way:

1. In the selection menu, start the ECU-sprayer application. The screens of the DISTANCE-Control II system are integrated into this application.

The work screen of the PTx Trimble ECU sprayer appears.

The figure of the boom is overlaid with the following icon **MANU**:

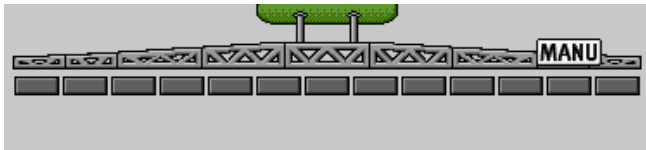

The icon indicates that DISTANCE-Control is running in manual mode and is not controlling anything.

- DISTANCE-Control II is in manual mode after every restart.
- If the icon does not appear immediately following a restart, DISTANCE-Control II is not installed on the ECU.
- You have started the ECU.

Screen Layout on the "System Data" Screen

All settings for DISTANCE-Control are made in the "System Data" screen.

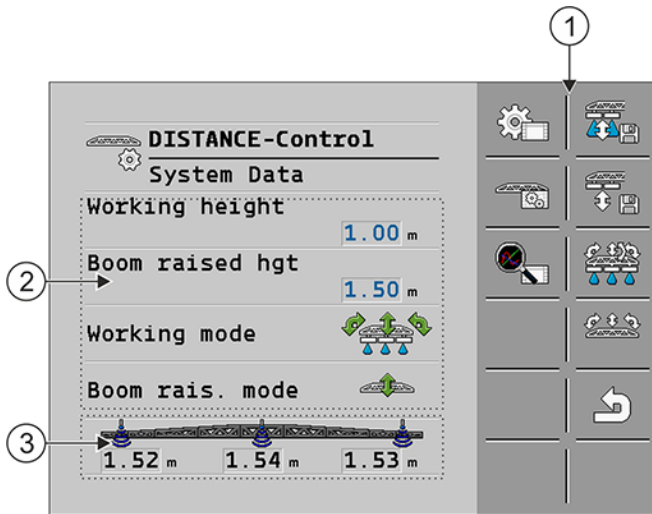

“System Data” screen

Item	Description
1	Function icons for operations
2	Parameter with current settings
3	Currently measured distance to the ground below

Operating DISTANCE-Control II on the Field

Activating DISTANCE-Control and Switching to Manual Mode

The work screen of the ECU tells you what mode DISTANCE-Control is working in.

DISTANCE-Control working modes

Mode	Display in the work screen	Behavior
Manual mode		No automatic control
Automatic mode		The boom position is controlled automatically.

DANGER!

SERIOUS PHYSICAL INJURY OR DEATH DUE TO LOWERING THE BOOM

WHEN THE ECU CONTROLS THE POSITION OF THE BOOM AUTOMATICALLY, THIS CAN HIT ADJACENT PERSONS AND OBJECTS.



BEFORE ACTIVATING AUTOMATIC MODE:

- **CHECK THAT NO ONE IS WITHIN RANGE OF THE BOOM!**
- **ENSURE THAT THERE ARE NO OBJECTS, POWER LINES OR TREES WITHIN RANGE OF THE BOOM!**

Before you activate and deactivate the system, make sure the boom is unfolded.

1. Start the ECU.

After restarting, the system is always in manual mode.



2. - On the work screen, press to activate automatic mode.

The icon **MANU** disappears:



DISTANCE-Control is activated in automatic mode.

Setting Working Mode and Boom rais. Mode



The “System Data” screen contains the following parameters:

- Working mode – defines what DISTANCE-Control should control during application.
- Boom rais. mode – defines what DISTANCE-Control should control following application. This parameter only appears when the system can tilt the boom.

Available Working Modes

Icon	This controls the system during spraying
	The system lifts and lowers the boom.
	The system slopes the boom - e.g. on hillsides.
	Tilting the boom – e.g. on ridges and in depressions
	Lifting, lowering and sloping the boom
	Lifting, lowering and tilting the boom

Available Boom rais. Modes

Icon	This controls the system in the event of closed sections
	The boom will be raised to the boom raising height.
	The boom will be tilted until the outer ultrasonic sensors reach the boom raising height.

To configure the mode:

1. Open the “System Data” screen on DISTANCE-Control II:



2.  - Press this key to select the working mode.

Arrows appear on the icon next to the “Working mode” parameter, indicating what the system will control.

3.  - Press this key to select the “Boom raising height” parameter. (No individual spray cones are visible under the boom icon in the icon.)

Arrows appear on the icon next to the “Boom rais. mode” parameter, indicating what the system will control.

Setting the Working Height and Boom Raising Height

You must define the distance between the boom and the plants so that the system can control this.

The “System Data” screen includes two parameters for setting these distances:

- Working height – the distance between the boom and the plants when at least one section is applying.
- Boom raising height - The distance between the boom and the plants when no sections are applying.



You can input a value for both parameters using the rotary knob, or configure these while working in the field.

To configure the “Working height” parameter when in the field:

1. Drive the field sprayer to the field.
2. Unfold the boom.
3. Ensure that the ultrasonic sensors are positioned above the plants.
4. Open the “System Data” screen on DISTANCE-Control II:



5. First configure the “Working height” parameter.
6. Move the boom to the height above the plants which the system should maintain during application. Use the PTx joystick to do this.

7.  - Save this height as the “Working height”.
The value of the “Working height” parameter will then change.
8. Now configure the “Boom raising height” parameter.
9. Move the boom to the height above the plants which the system should maintain immediately following application.
10.  - Save this height as the “Boom raising height”.
The value of the “Boom raising height” parameter will then change.

Configuring DISTANCE-Control II

“System Data” Screen

All settings for DISTANCE-Control are made in the “System Data” screen.

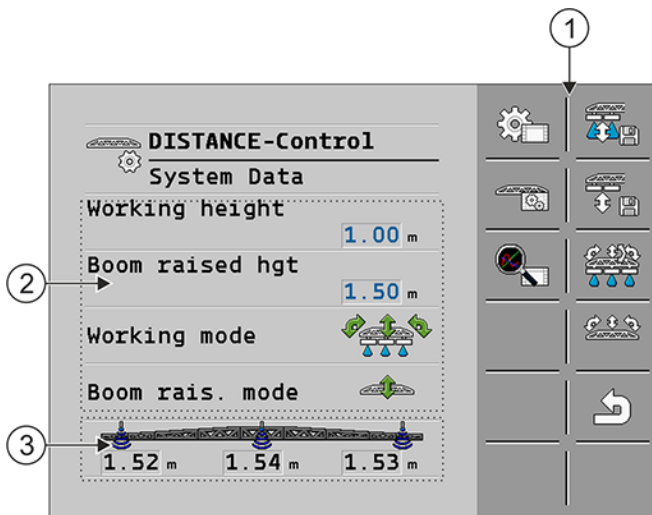

“System Data” screen

Item	Description
1	Function icons for operations
2	Parameter with current settings
3	Currently measured distance to the ground below

Calibrating DISTANCE-Control

You must calibrate the system in the following instances:

- During one of the initial start-ups.
- If an angle sensor or ultrasonic sensor is replaced or if its position is changed.

- If you detect that the control is not functioning correctly.

Calibration teaches the system the position of the sensors when the boom is in a specific position. The system can then calculate and recognize other positions of the boom.

Special case: 5 or 6 ultrasonic sensors

On field sprayers with 5 or 6 ultrasonic sensors, i.e. with two ultrasonic sensors on each wing, the sensor installed on the inside must be disconnected from the cable before performing the calibration. During the calibration procedure, there may only be one ultrasonic sensor on each wing.

The location where you calibrate the system must meet the following criteria:









- The ground must be flat and even over the entire width of the boom. The distance to the ground in the horizontal position must be the same on both sides.
- The ground below must be able to provide a proper reflection for the ultrasonic sensors. The following are unsuitable: Gravel, asphalt. The following are suitable: Soil.

When performing the calibration on a plant site, where the ground below provides weak ultrasonic signal reflection, you can place something which will properly reflect the ultrasonic signals on the ground under the ultrasonic sensors. For example, a carpet.

- This must provide sufficient space to move the boom to all extreme positions.
- There must be no power lines nearby which might be affected by the boom.

Controls

The joystick is deactivated during the entire calibration. You can only operate the field sprayer with the function keys which appear on the display screen.

Icon	Meaning	Icon	Meaning
	Lift boom		Tilt the left wing downward
	Lower boom		Tilt the right wing downward
	Tilt the left wing upward		Slope the boom – lift the left side
	Tilt the right wing upward		Slope the boom – raise the right side

To start calibration:

1. Drive the field sprayer to a location where the calibration can be performed.
2. Open the “System Data” screen on DISTANCE-Control II:



The following screen appears:

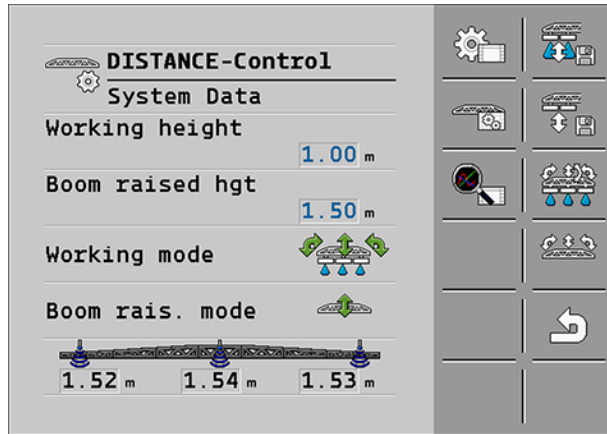

3.  - Open the "Calibration" screen.

The following screen appears:

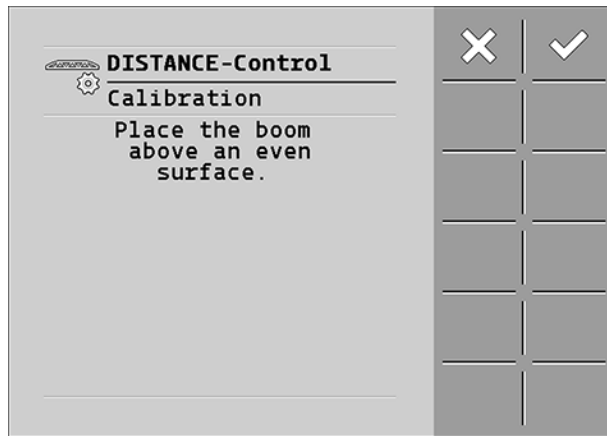

The display screen will show you what to do in the next step.

4. In this instance, place the unfolded boom above an even area.
5.  - When you have completed this task, acknowledge this.

Depending on the design of the field sprayer, one of the following screens appears:

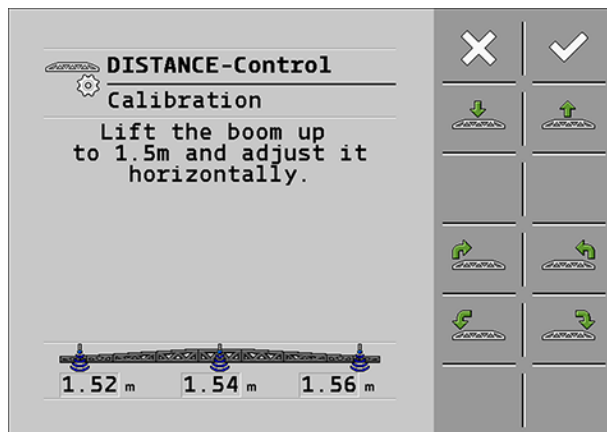

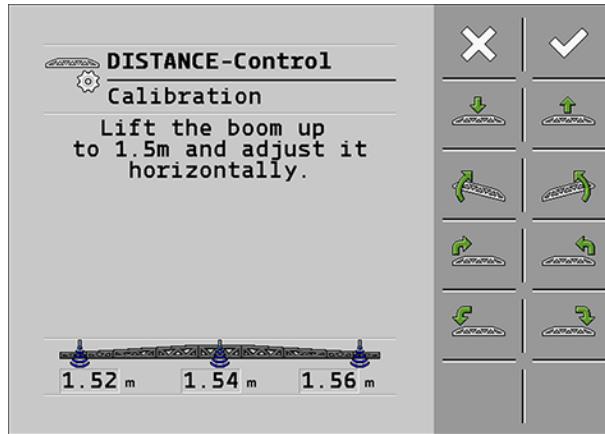



- Follow the instructions on the display screen. You will find additional information on each step of the calibration on the next pages.

Teaching the Horizontal Position

In this step, you will calibrate the horizontal position of the boom.

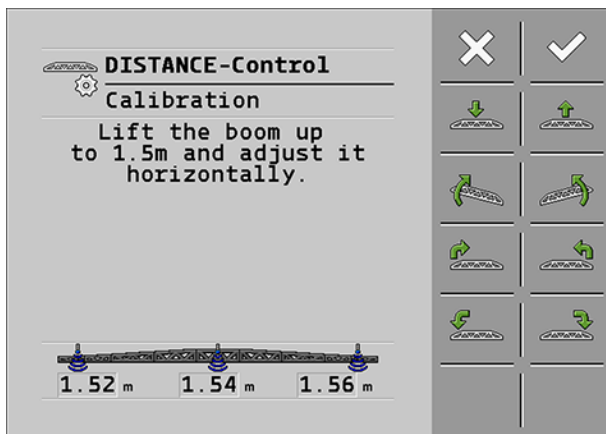
The following screen appears on the display screen:





- Position the boom horizontal and parallel to the ground at a height of approx. 1.50 m - 1.60 m.
The display screen will show you the distance of each ultrasonic sensor from the ground. This display is updated throughout the calibration.
- Check the alignment visually and on the basis of the sensor values on the display screen.
-  - Confirm.



Determining the Start Point of Sloping

In this step you will determine the opening of the hydraulic valve at which the boom starts to slope.

The following text appears on the display screen: "Raise PWM intensity until the system reports a movement."

1.  - Hold this key down until the following text appears: "Movement detected."
2.  - Confirm.



The following text appears on the display screen: "Raise PWM intensity until the system reports a movement."

3.  - Hold this key down until the following text appears: "Movement detected."
4.  - Confirm.



Calibrating the Maximum Slope Angle

In this step you will bring the system to a point where the boom reaches a maximum slope angle.

The following text appears on the display screen: "Turn boom clockwise down to the ground."

1.  - Slope the boom as far as possible to the right. The right end of the boom must remain a few centimeters above the ground and must not touch this. The right ultrasonic sensor must not be closer than 30cm to the ground.
2. Wait until the boom is no longer moving. If necessary, correct the position of the boom.
3.  - Confirm.

The following text appears: "Turn boom counter-clockwise down to the ground."

4.  - Slope the boom as far as possible to the left. The left end of the boom must remain a few centimeters above the ground and must not touch this. The left ultrasonic sensor must not be closer than 30 cm to the ground.
5. Wait until the boom is no longer moving. If necessary, correct the position of the boom.
6.  - Confirm.

Adjusting the Boom Horizontally





The following text appears on the display screen: "Adjust the boom horizontally again."

1. Use the keys to adjust the boom horizontally.
2.  - Confirm.

Determining the Start Point of a Tilting Movement

In this step you will determine the opening of the valve at which the left and right wing start to tilt upward.



The following text appears on the display screen: "Raise PWM intensity until the system reports a movement."

1.  - Hold this key down until the following text appears: "Movement detected."
2.  - Confirm.
3.  - Hold this key down until the following text appears: "Movement detected."
4.  - Confirm.
5. Repeat this step for the right wing.



Calibrating the Angle Sensors

In this step you will determine how the potentiometer of an angle sensor behaves when a boom is tilted upward or downward.

The following text appears on the display screen: "Raise left wing to approx. 2.5m of height."

1.  - Tilt the left wing upward until the left ultrasonic sensor is approx. 2.5m above the ground. (+/- 10cm).
2. Wait until the boom is no longer moving and stops swinging.
3.  - Confirm.

The following text appears: "Turn boom counter-clockwise down to the ground."

4.  - Tilt the left wing downward until the left ultrasonic sensor is approx. 0.5m above the ground.
5. Wait until the boom is no longer moving and stops swinging.
6.  - Confirm.
7. Adjust the boom horizontally.
8.  - Confirm.

The following text appears on the display screen: "Raise right wing to approx. 2.5m of height."

9. Repeat this procedure for the right wing.

Calibrating Maximum and Minimum Angles for Upward Tilt Movements

In this step you will calibrate:





- The maximum angle for upward tilt movements.
- The minimum angle for downward tilt movements.

The position of the wings will only be controlled only up to these angles during work.





When setting the maximum and minimum limit angles, note the following factors:

- The height of power lines and the length of the wing;
- Mechanical restrictions of the boom;
- The ultrasonic sensors may be moved a maximum of 3m above the ground.

The following text appears on the display screen: "Raise both wings to maximum working angle."

1.  - Lower the boom to its minimum height. This will increase the chance that the ultrasonic sensors will not move higher than 3m.
2.  and  - Tilt both parts of the boom upwards. Find the maximum angle which still allows safe, efficient working.
3.  - Confirm.



The following text appears: "Lower both wings to maximum working angle."

4. Adjust the boom horizontally.
5.  - Lift the boom to its maximum height.
6.  and  - Tilt both parts of the boom downwards. Find the minimum angle which still allows safe, efficient working.
7.  - Confirm.

Completing the Calibration

In this step you will decide whether to save or delete the values that you determined during the calibration.

The following text appears on the display screen: "DISTANCE-Control is now calibrated."

1. To accept the determined values, press: 
2. To delete the determined values, press: 

Using the Password-Protected Area for Configuration

Following installation and calibration, you have the option of defining all of the control parameters even more precisely.

You can make the following settings in the password-protected area:

1. Input the exact position of the ultrasonic sensors.
2. Adjust reaction speed for manual operation.
3. Adjust control speed in automatic mode.
4. Configure tolerances.
5. Set a maximum speed.
6. Configure special functions.

NOTE - Only make changes to parameters which are explained in this manual.

If you make changes to other parameters, it is possible that the system will no longer function properly.

Opening the Password-Protected Area

1. Open the "System Data" screen on DISTANCE-Control II:



2.  - Press this key.
3. A screen with a field for inputting the password appears.
4. Input the password **456123**.
5. The "Configuration" screen appears.

You can now perform the configuration.

Selecting the Configuration Method

You can configure the parameters in the password-protected area in two different ways:

- Configuration using the function icon and parameter name
- Configuration using the internal name





Note that for some parameters, only one of the two configuration methods can be used.

Configuration Using the Function Icon and Parameter Name

On the "Configuration" screen, the individual parameters are grouped under different icons. The respective parameters can be configured there.

Controls

Use the following function keys to operate the function:

Icon	Meaning
	Configure the raising height.
	Configure the slope.
	Configure the wings.
	Configure the offsets.
	Open the configuration using the internal name.

Configuration Using the Internal Name

Each parameter has an internal name, which you need for the configuration. When configuring using this name, you can configure all of the parameters on a screen.

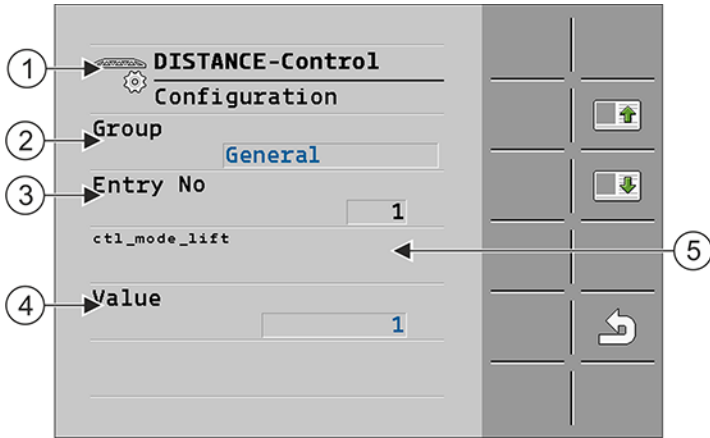

Information on the "Configuration" screen

Item	Description	Item	Description
1	Screen name	4	Current value of selected parameter
2	Activated group with parameters	5	Designation of the selected parameter
3	Number of selected parameter		

Before you begin, make sure:

- You have entered the password.
- The following screen is called up: "Configuration"



1. - Press.
2. Click the field in the "Group" line.

A list of available parameter groups appears:

3. Click on the desired group.
- The following screen appears: "Configuration"

The designation of the selected group appears in the "Group" line.



4. - Select the parameter you want to configure.
5. Click on the field in the "Value" line.

The data input screen appears.

6. Input a new value for the parameter.
7. Press "OK" to confirm.

The new value appears on the "Value" line on the "Configuration" screen.

You have changed the value of a parameter.

These changes will only take effect once the ECU is restarted.



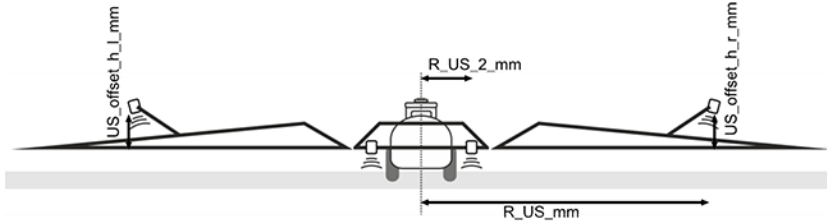

Inputting the Position of the Ultrasonic Sensors

The following illustration shows the distances that you must determine and the parameters to which they are assigned:



Parameter for determining the position of the ultrasonic sensors

Parameters in the “Sensorics” Group

Parameter	Description
 - Ultrasonic sensor - Distance from the centre Group: Sensors R_US_mm	Distance of the right outer ultrasonic sensor from the middle. Since the distance is only specified for the right side, please note that the sensors on the right and left must be installed at the same distance from the center of the boom.
Group: Sensors R_US_2_mm	Distance from the center of the field sprayer to the right ultrasonic sensor on the center section of the boom. Since the distance is only specified for the right side, please note that the sensors on the right and left must be installed at the same distance from the center of the boom.
 - Ultrasonic sensor offset, left Group: Sensors US_offset_h_l_mm	Distance of the left outer ultrasonic sensor from the nozzles. <ul style="list-style-type: none"> ▪ Sensor above the nozzles = positive value ▪ Sensor below the nozzles = negative value
 - Ultrasonic sensor offset, right Group: Sensors US_offset_h_r_mm	Distance of the right outer ultrasonic sensor from the nozzles.
 - Ultrasonic sensor offset, center Group: Sensors US_offset_h_r2_mm	Distance of the center ultrasonic sensor from the nozzles.





Parameter	Description
	Number of ultrasonic sensors
Group: Sensors Number_US_sensors	

Adjusting Reaction Speed for Manual Operation

In this step you will define how fast the system should react to a key press.

A parameter is provided for each direction of movement. The values are percentage values for the PWM within a range of 0 to 1 (0.01 = 1%) with 0.002 steps. It is however sufficient in most cases to change the values in steps of 0.01.





NOTE - The functions of Parameters 13 and 14 can be reversed if need be!

Parameter	Description
 - Manual slope CW	Speed at which the boom is sloped in manual mode (left side is raised).
Group: PWM slope_move_ext_dPWM_dn	
 - Manual slope CCW	Speed at which the boom is sloped in manual mode (right side is raised).
Group: PWM slope_move_ext_dPWM_up	
 - Wings manual down - L	Speed at which the left wing is tilted downward in manual mode.
Group: PWM l_wing_move_ext_dPWM_dn	
 - Wings manual up - L	Speed at which the left wing is tilted upward in manual mode.
Group: PWM l_wing_move_ext_dPWM_up	
 - Wings manual down - R	Speed at which the right wing is tilted downward in manual mode.
Group: PWM r_wing_move_ext_dPWM_dn	





Parameter	Description
 - Wings manual up - R Group: PWM r_wing_move_ext_dPWM_up	Speed at which the right wing is tilted upward in manual mode.

Adjusting the Control Speed in Automatic Mode





It is sometimes necessary to adjust the automatic control speeds during initial commissioning or in the event of a customer complaint. A parameter is also provided for each function and direction of movement. However, these are not percentages but factors, meaning that even a small change can already have an impact.

Parameter	Description
 - Slope P Group: Control sl_ctl_prop_factor	Amplification factor for the height deviation. Per default, this value should always be set to 1.0.
 - Slope D Group: Control sl_ctl_dif_factor	Differential factor for the height deviation. A positive value makes the control fast, but also more susceptible to faults. A negative value can be sensible to make the system run more smoothly.
 - Slope D2 Group: Control sl_ctl_ddif_factor	Factor that is used to improve the reactions of the controls. The higher the value, the higher the speed at which control begins. The target rate is then reached more slowly.
 - Slope factor CW Group: PWM slope_act_PWM_down_factor	Speed at which the slope to the right is controlled in automatic mode.
 - Slope factor CCW Group: PWM slope_act_PWM_up_factor	Speed at which the slope to the left is controlled in automatic mode.

Parameter	Description
 - Gyroscope factor Group: Control	Value that regulates the influence of the gyroscope on the controls when driving in curves.
Group: PWM slope_act_PWM_ dn_offset	Internal parameter that is determined during calibration. Please do not adjust.
Group: PWM slope_act_PWM_ up_offset	Internal parameter that is determined during calibration. Please do not adjust.
 - Wings P Group: Control wing_ctl_prop_ factor	Amplification factor for the height deviation. Per default, this value should always be set to 1.0.
 - Wings D Group: Control wing_ctl_dif_ factor	Differential factor for the height deviation. A positive values makes the control fast, but also more susceptible to faults. A negative value can be sensible to make the system run more smoothly.
 - Wings D2 Group: wing_ctl_ddif_ factor	Factor that is used to improve the behavior of the controls. The higher the value, the higher the speed at which control begins. The target rate is then reached more slowly.
 - Wings factor down - L Group: PWM l_wing_act_PWM_ dn_factor	Speed at which the downward tilt movement of the left wing is controlled in automatic mode.

Parameter	Description
 - Wings factor up - L	Speed at which the upward tilt movement of the left wing is controlled in automatic mode.
Group: PWM l_wing_act_PWM_up_factor	
 - Wings factor down - R	Speed at which the downward tilt movement of the right wing is controlled in automatic mode.
Group: PWM r_wing_act_PWM_dn_factor	
 - Wings factor up - R	Speed at which the upward tilt movement of the right wing is controlled in automatic mode.
Group: PWM r_wing_act_PWM_up_factor	
 - Wings factor cross	Factor that compensates the influence of one wing on the other respective wing.
Group: Control wing_cross_err_factor	

Sloping Control Speed

-  - Activate manual mode of DISTANCE-Control II.
- Set the following working mode: 
-  - Slope the boom down to the ground on the right side.
-  - Activate automatic mode.

The system will move the boom to the horizontal position.

- Observe the movement.

The boom must move gently to the horizontal position, without exceeding it.

- If the boom moves too slowly, increase the value of the "slope_act_PWM_up_factor" parameter (PWM group, parameter 8). Change the value in 0.001 steps.

7. If the boom moves too rapidly, reduce the value of the “slope_act_PWM_up_factor” parameter (PWM group, parameter 8). Change the value in 0.001 steps.
8. Repeat this test for the left side.
9. Adjust the “slope_act_PWM_down_factor” parameter. (Group PWM, parameter 6).

Upward Tilt Movement Control Speed

1.  - Activate manual mode of DISTANCE-Control II.

2. Set the following working mode: 

3.  - Tilt the left wing downward.

4.  - Activate automatic mode.

The wing moves to the horizontal position.

5. Observe the movement.

The boom must move gently to the horizontal position, without exceeding it.

6. If the boom moves too slowly, increase the value of the “l_wing_act_PWM_up_factor” parameter (PWM group, parameter 17). Change the value in 0.001 steps.
7. If the boom moves too rapidly, reduce the value of the “l_wing_act_PWM_up_factor” parameter (PWM group, parameter 17). Change the value in 0.001 steps.

8.  - Activate manual mode of DISTANCE-Control II.

9.  - Tilt the left wing upward.

10.  - Activate automatic mode.

The wing moves to the horizontal position.

11. Observe the movement.

The boom must move gently to the horizontal position, without exceeding the horizontal.

12. If the boom moves too slowly, increase the value of the “l_wing_act_PWM_dn_factor” parameter (PWM group, parameter 15). Change the value in 0.001 steps.
13. If the boom moves too rapidly, reduce the value of the “l_wing_act_PWM_dn_factor” parameter (PWM group, parameter 15). Change the value in 0.001 steps.
14. In most cases it is possible to directly transfer the values for the left wing to the right wing. “r_wing_act_PWM_up_factor” (group PWM, parameter 26) and “r_wing_act_PWM_dn_factor” (group PWM, parameter 24) are the corresponding parameters for the right wing. If the behavior is different, however, repeat the procedure for the right wing.



Configuring Tolerances

Tolerances are used to define an area within which the boom can move freely without control intervention.

If the tolerances are too narrow, the system will be controlled too often and too rapidly. This can lead to oscillation along the entire boom.

If the tolerances are too wide, the system will work imprecisely.

Parameters for configuring the tolerances

Parameter	Description
 - Lifting tolerance Group: General height_tolerance_lift_mm	Tolerance for height control of the entire boom in mm. Values between 150-200 mm are useful, as raising and lowering can shake the entire boom.
 - Wing tolerance Group: General height_tolerance_wings_mm	Tolerance for height control of the wing in mm. Values between 70-100 mm can be entered here.
 - Slope tolerance Group: General slope_tolerance_deg	Tolerance for slope control (in degrees). Values within a range of 0.2° to 0.4° make sense.

Setting the Maximum Speed

If the field sprayer moves faster than the maximum permitted speed, DISTANCE-Control II will switch to manual mode.

Parameter	Description
Group: General v_max_for_control	Maximum speed at which DISTANCE-Control II will function.

Special Functions

Automatic Slope Centering When Lifting the Boom and When Performing Tilt Movements

Some field sprayer manufacturers like an automatic function which ensures that the central section of the boom is moved to a horizontal position before performing another function.

This function is deactivated by default.

Parameter for automatic boom centering

Parameter	Description
	Automatic centering of the slope of the center boom segment - before another function is executed.
Group: General slope_centrage	0 – Switched off 1 – Switched on
	The value of the angle sensor in the horizontal position is saved here. You can adjust this manually if it is wrong. The value is determined during the calibration.
Group: General slope_poti_dest_position	
	This parameter determines from which angle sensor value the boom should be moved to the horizontal position. Values higher than 15 make sense, but are however dependent on the usage range of the angle sensor.
Group: General slope_poti_dest_position_tol	

Triggering a Control Stop with Sensors

The system offers the option to stop any control system as soon as a safety-relevant sensor sends a signal.

“Sensors can stop control” parameter - Possible sensors

Value	Sensor	This is what happens when the sensor sends a signal
1	Boom locking sensor	Terminates automatic mode and interrupts the control.
2	Boom unlocking sensor	Enables the activation of automatic mode.
4	Boom pole sensor	Terminates automatic mode and interrupts the control.
8	Boom in transport position	Terminates automatic mode and interrupts the control.
16	Boom height for folding	Terminates automatic mode and interrupts the control.
32	Critical boom height	Terminates automatic mode and interrupts the control.

Add the values for all of the sensors to be configured and enter the sum as the parameter value.

Extras

The system offers the option of deactivating some of the functions. Therefore, it is possible to observe e.g. only the tilting during start-up.

“Extras” parameter

Value	This is what happens when the sensor sends a signal
8	Deactivates the lifting / lowering function.
16	Deactivates the sloping function.
32	Deactivates the tilting function.
128	Activates an acoustic signal that indicates the change to manual mode.

Add the values for all of the sensors to be configured and enter the sum as the parameter value.

Troubleshooting DISTANCE-Control

Frequent Issues

Problem description	Measure
The control system is too slow.	<ul style="list-style-type: none"> • Calibrate the system • Adjust the reaction speeds in automatic mode.
The speed is too slow in manual mode.	<ul style="list-style-type: none"> • Adjusting reaction speed for manual operation
The control system oscillates.	<ul style="list-style-type: none"> • Check the control system tolerances. • Adjust the reaction speeds in automatic mode. • If slope centering is active, try switching this off to assess which control system is the cause.
Hydraulic valve/bypass valve does not actuate	<ul style="list-style-type: none"> • Check which ECU the valve is connected to. • Check the configuration of this ECU. • If necessary, redo the configuration with the PTx Trimble Configurator. • Sprayer configuration conditions are transferred from the DCII.
Automatic mode cannot be switched on	<ul style="list-style-type: none"> • A sensor is faulty. The corresponding error message with alarm screen should appear. • A sensor prevents automatic mode (folding sensor, work position sensor).
Automatic mode is suddenly exited (hand appears on the terminal)	<ul style="list-style-type: none"> • Check to see if the maximum speed has been exceeded. • Check to see if the user has attempted to fold or unfold the boom.
The control system regulates in reverse.	<ul style="list-style-type: none"> • Check that all hydraulic functions are connected in the right order. • Check whether the angle sensors are functioning correctly.
Certain control modes are not available.	<ul style="list-style-type: none"> • Faulty configuration. Repeat the configuration.
The joystick cannot be used during calibration.	<ul style="list-style-type: none"> • This is not a fault. The joystick is always deactivated during calibration.
The horizontal position can no longer be established during calibration. Calibration cannot be fully completed.	<ul style="list-style-type: none"> • Check the hydraulic system for leaks.

Finding the Source of a Short Circuit

If the ECU reports the failure of several sensors at the same time, it is an indication for a short circuit - for example, due to a crushed cable for a sensor.

As soon as a short circuit is detected, the ECU switches off the power supply. This is why all of the sensors that are connected to the switched-off power source fail at the same time.

When the short circuit has been fixed, it only takes a few seconds for the ECU to activate the power supply.

Angle and slope sensors are supplied by a power source, possibly together with other sensors, such as the wheel sensor, gyroscope, or flow meter (depending on the system).

Because of the higher power requirement, the ultrasonic sensors have a separate power supply. See section: Ultrasonic sensors

To find and fix the cause of a short circuit:

1. Open the junction box.
2. Disconnect all of the affected sensors successively from the power supply. Each time you disconnect a sensor, measure the power supply in the junction box with a multimeter. Measure between the terminals 0V and 12V.
3. Disconnect the sensors successively until the power is back on. The sensor with which the power supply was reactivated when it was disconnected, is faulty.
4. Replace the cable or the sensor.
5. Reconnect the sensor in the junction box.

Extension: EDS

- About EDS
- Mounting and Installation
- Operating Individual Nozzle Switching on the Field
- Configuring the Single Nozzle Switching
- Vario and Select Mode - Configuring Multiple Nozzle Holders
- Configuring CURVE-Control
- Troubleshooting EDS

About EDS

System Functions

The single nozzle switching system [also called EDS] is a system that serves to directly open and close each nozzle on a field sprayer.

This makes it possible to reduce the number of overlaps more effectively than with conventional systems, which can only open and close entire sections.

The system obtains all of the required information from the ECU of the sprayer and the SECTION-Control application. This gives the driver the ability to either control the nozzles manually, or allow them to be controlled by the software.

System Overview

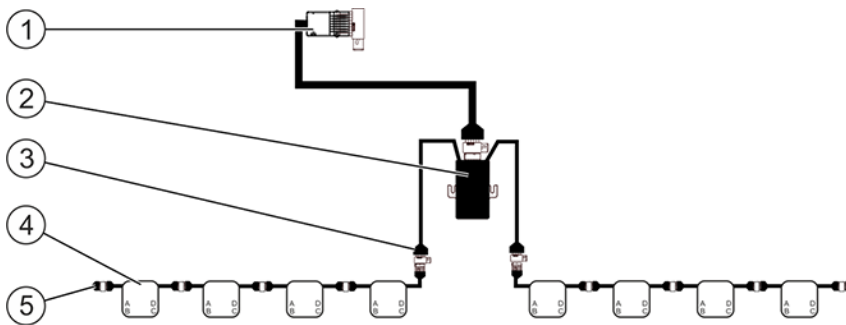

EDS

Item	Description	Item	Description
1	Connection to the main system or to a system add-on	4	EDS modules
2	EDS communication module	5	Termination plug
3	Connection to the EDS bus		

EDS Communication Module

The EDS communication module controls the EDS modules. It receives signals from the ISOBUS ECU and sends commands to the EDS modules.

EDS Bus

EDS Bus is a data line from the EDS communication module to all of the EDS modules.

The EDS communication module is connected with two EDS modules at the middle of the boom. Other modules are connected to this module in a chain.

EDS Module

An EDS module is a microprocessor that opens or closes the feed line to a nozzle.

The EDS modules described in these operating instructions work with air pressure. They are also called pneumatic EDS modules or EDS-P modules.

EDS modules differ in terms of:

- the diameter of the quick connectors
- the type of the multiple nozzle holders that they can control
- Item numbers

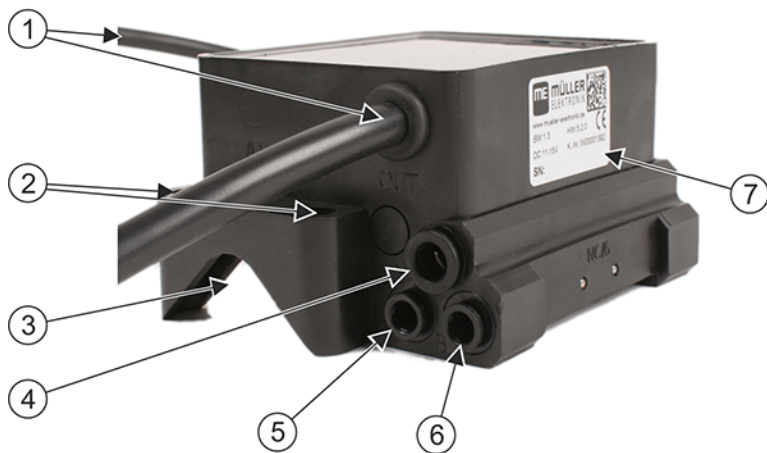

Pneumatic EDS module (EDS P Module) The following labels can be found on the module casing

Item	Description	Item	Description
1	Output (OUT) and input (IN) of the EDS Bus line	5	Quick connector for pneumatic output A Diameter: 4 mm or 6 mm, depending on the model
2	Openings for the U-bracket	6	Quick connector for pneumatic output B The pneumatic outputs C and D are located on the opposite side.
3	Slot for the spray agent pipe	7	Rating plate
4	Quick connector for the pneumatic line (main line) Diameter: 8 mm		

Nozzle Holders

The system can work with the following types of nozzle holders:

- Single nozzle holder
- Double nozzle holder - multiple nozzle holder with two nozzles.

Requirement: ISOBUS ECU manufactured by PTx Trimble with a license for VarioSelect nozzle holders.

The more nozzle holders are connected to an EDS module, the longer the required connection cables for the EDS modules. For this reason, there is a different EDS module for each type of nozzle holder.

You can see it by the item number on the rating plate. The various item numbers can be found in Section: Spare parts

Intended Uses

The EDS system can be installed on the field sprayer for different intended uses:

- Single-nozzle switching
- Pairwise nozzle switching
- Section control

Examples:

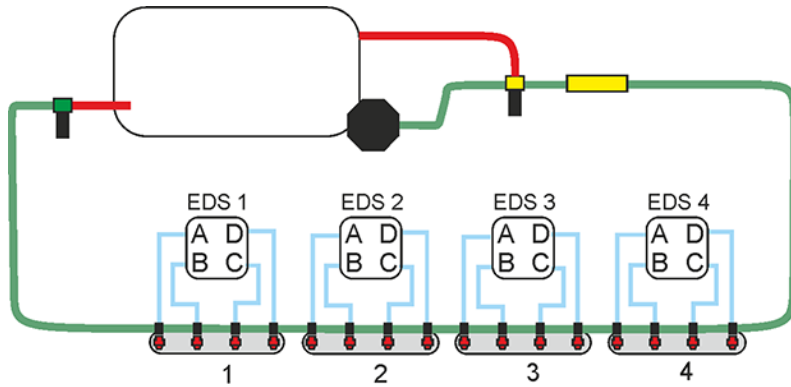

Individual nozzle switching with single nozzle holders and four sections

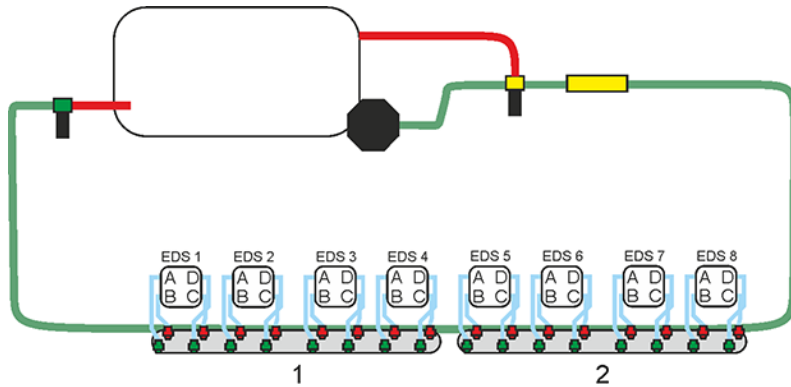

Individual nozzle switching with double nozzle holders and two sections

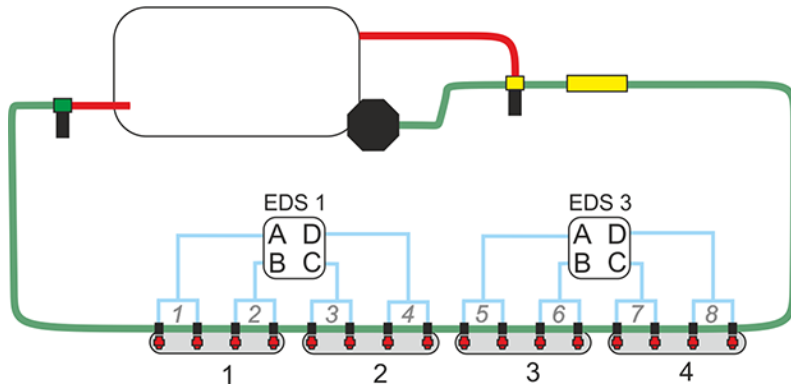

Pairwise nozzle switching with single nozzle holders and four sections

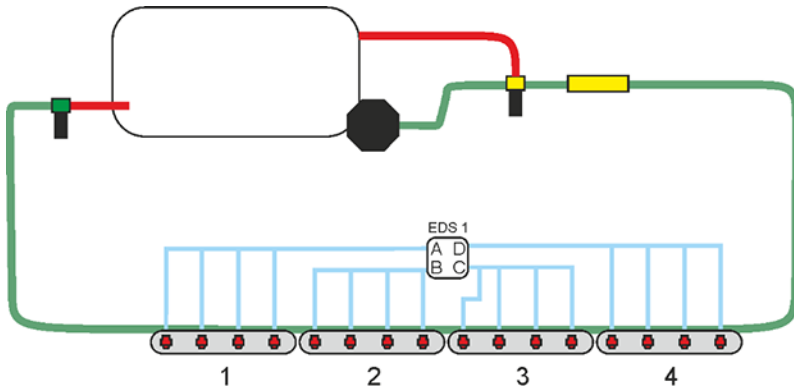

Section control with single nozzle holder

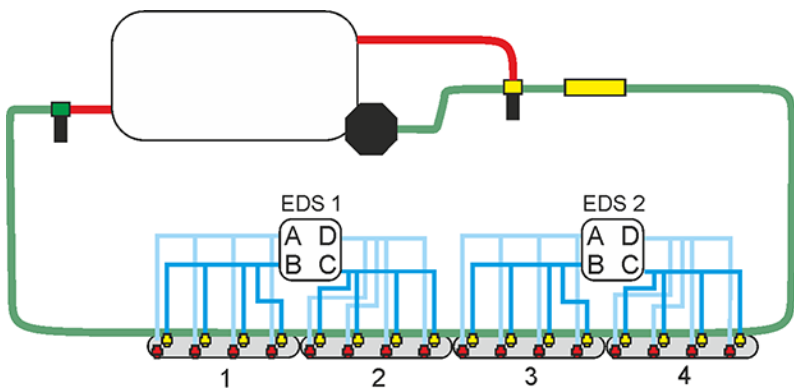

Section control with double nozzle holder.

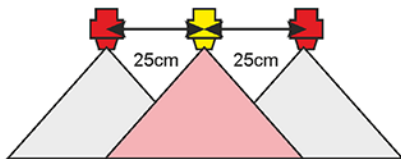
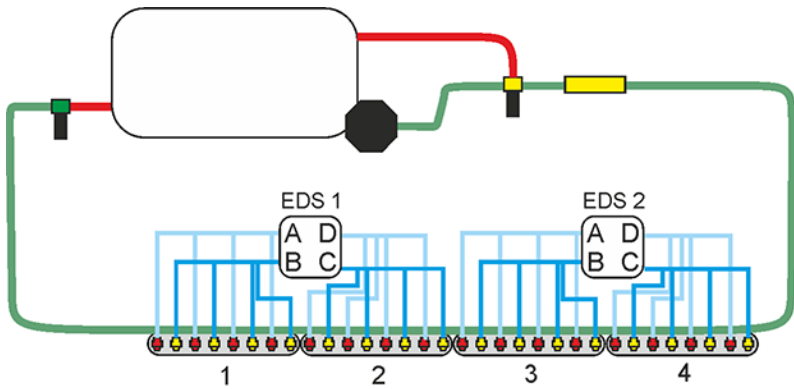

Section control with EDS modules. In this version single nozzle holders are installed every 25 cm.

Mounting and Installation

Install the EDS Communication Module

The EDS communication module must be firmly installed on the field sprayer.

The place of installation must be selected such that the ISOBUS ECU and the EDS modules can be connected later on.

Mounting EDS Modules

You should bear the following in mind when installing the EDS modules:

- Install the EDS modules on the field sprayer boom, close to the nozzle holders.
- To attach the EDS modules, you can use e.g. the universal bracket in the form of a U-bolt (M5).
- The position of the EDS module is irrelevant. It is only important that all of the nozzle holders can be easily reached with the hoses.
- Pneumatic valves must be connected to the nozzles in a specific sequence.
- The connectors must be connected to the nozzles in a specific sequence.
- On field sprayers with more than 72 EDS modules, additional power must be supplied to the outer half of the EDS modules on each wing. The following cable harnesses are used for this purpose: 3030308340 and 3030308341

Preventing Leaks

Observe the following instructions to prevent leaks in the system:

- Protect the pneumatic connections and plug contacts of the EDS modules from humidity and dust. The pneumatic connections must be clean both during installation and also during transport and storage. Dirty connections can cause leaks.
- Only use pneumatic hoses made of hard plastic like polyamide (PA). Soft hoses, e.g. made of polyurethane (PU) or polyethylene (PE), can cause leaks in the connection area of the EDS module.
- Do not paint the EDS modules.
- Use quick exhausts to prevent spray liquid from entering the EDS modules.

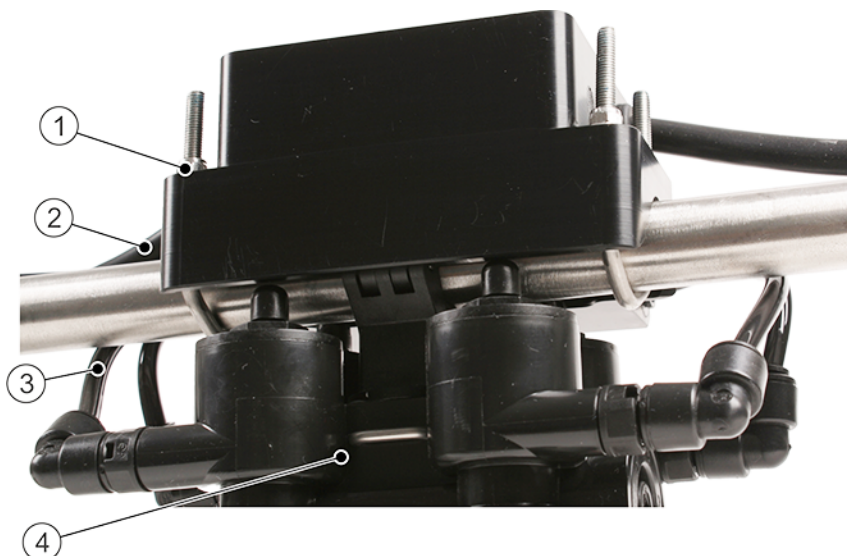

Installation example: EDS-P module installed directly over a quadruple nozzle holder

Item	Description
1	Universal bracket M5 for attachment to the pipe
2	Cable for the EDS line. The main pneumatic line cannot be seen on this photo.
3	Each pneumatic valve is connected with a hose to one nozzle.
4	The nozzle holder is located directly below the EDS module.

Connecting the Nozzle Holders to the EDS Modules

Planning the Sequence

The sequence in which you must connect the nozzles to the pneumatic valves depends on the nozzle holders that you are using:

- Single nozzle holders
 - One pneumatic valve per nozzle holder.
 - A, B, C, D from left to right.
 - If you cannot maintain the sequence on an EDS module and the nozzle holders are connected in the sequence D, C, B, A, you have to mark this EDS module as “rotated”. See: "EDS" tab
 - If the number of nozzles on each side of the boom cannot be divided by four, a few pneumatic valves are left over. These must always be the pneumatic valves located at the outer ends of the boom.

For example: If 22 nozzles are installed on the left side of the boom, two pneumatic valves are left over after the installation. They are located at the ends of the boom. On the left side, pneumatic valve A remains open, and on the right side, pneumatic valve D.

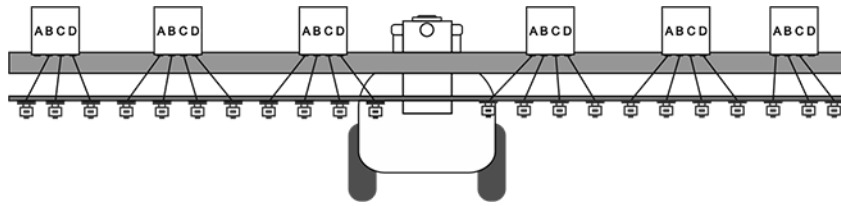

Arrangement of the pneumatic EDS modules on a boom with single nozzle holders

- Double nozzle holders
 - Connect pneumatic valves A, B with the first nozzle holder and pneumatic valves C, D with the second nozzle holder.
 - Pneumatic valve A and pneumatic valve C have to be connected to the same type of nozzle on all of the nozzle holders, because they are switched simultaneously.
- Quadruple nozzle holders
 - Use one EDS module per nozzle holder.
 - Each pneumatic valve must correspond to one nozzle type. This association must be maintained for all of the nozzle holders.

Connecting the Pneumatic Line to the EDS Modules

Before connecting the EDS modules to the air compressor, make sure that it fulfills the following requirements:

- The pneumatic system must include a central pressure regulator with filter and a water separator.
- Compressed air quality: Technical specifications of the EDS modules
- Operating pressure: Technical specifications of the EDS modules

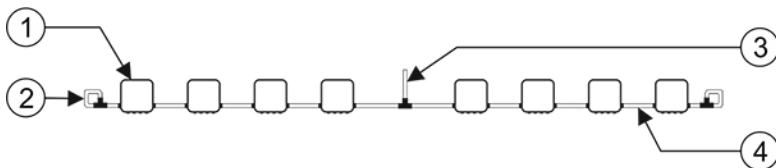

EDS modules and the pneumatic line

Item	Description	Item	Description
1	EDS module	3	Hose to the air compressor of the field sprayer
2	Loop or plug The hoses must be closed off at the ends.	4	Hose between the EDS modules Diameter: 8 mm

Inserting the Hose

1. Push the end of the hose into the opening of the quick connector.
The hose will be hooked onto the quick connector and cannot be pulled out.

Pulling Out the Hose

1. Press the quick connector towards the middle of the EDS module.
The locking mechanism releases the hose.

2. Pull the hose out. The hose can be pulled out very easily when the quick connector is properly pressed in.

Connecting the Cable

Every EDS module has two cables that can be used to connect to other modules and the communication module. The connected EDS modules thereby form a line. This line is called EDS BUS.

Connecting the Communication Module to the EDS Modules

The end of each cable from the communication module is marked with a letter:

- "L" - For connecting the EDS modules on the left side of the boom
- "R" - For connecting the EDS modules on the right side of the boom

Connecting the EDS Modules to Each Other

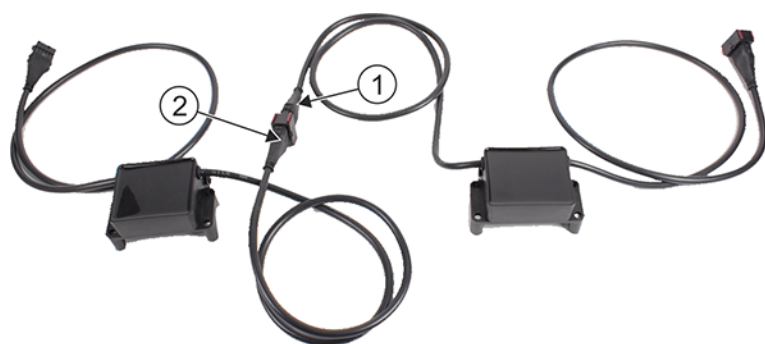

Connecting two EDS modules

Item	Description
1	EDS module input
2	EDS module output

Outer EDS Modules

There is one EDS module remaining on each side of the boom where the output cannot be connected to another EDS module. The outer outputs must be closed using the supplied terminating plugs.

Operating Individual Nozzle Switching on the Field

As soon as the EDS system is installed and configured, the work screen of the sprayer ECU application changes.

Nothing changes with the operation of the field sprayer.

On the following diagram, you can see how the single nozzle switching is shown on the work screen:

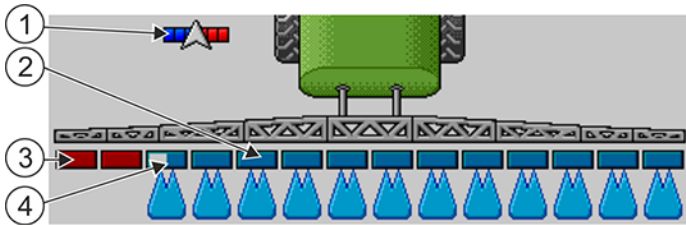

Representation of the switched EDS modules in the sprayer ECU application

Item	Description	Item	Description
1	Activated SECTION-Control	3	Switched-off nozzles These nozzles are not applying.
2	Switched-on nozzles These nozzles are applying.	4	Sections that are switched on and sections where at least one nozzle is switched on.

Configuring the Single Nozzle Switching

You must configure the individual nozzle switching in the application ECU SPRAYER-Controller 3.0 ECU.

Configuring the EDS Communication Module on the Terminal

Open the Application of the EDS Communication Module

Before you begin, make sure:

- You have properly connected all of the components.
- You have configured the SPRAYER-Controller 3.0 ECU.

1. Switch on the terminal.
2. Open the ECU application.
3. On the work screen, press:



The “EDS / Settings” screen appears. In this screen most settings are made.

Start Screen of the EDS Application

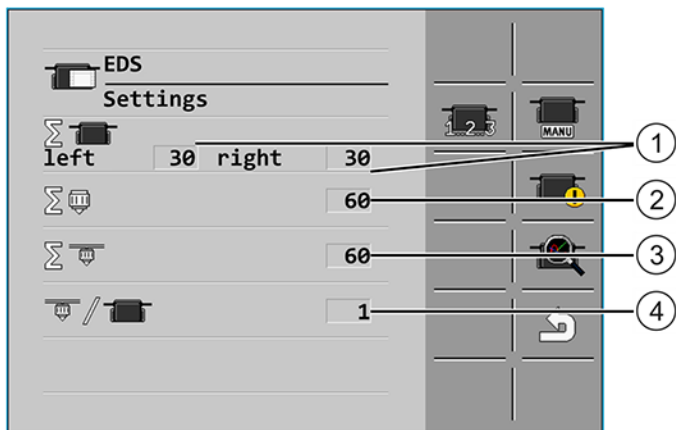

Start screen of the EDS application

Item	Description
1	Number of EDS modules on the left resp. right side of the boom. The system determines the numbers during the address allocation.
2	Sum of the nozzles.
3	Sum of the nozzle holders.
4	Number of nozzle holders on each EDS module.

Function Icon	Meaning
	Starts the address allocation.
	Opens the "EDS / Settings" screen.
	Enables manual switching of nozzles.
	Indicates the EDS modules on which errors were detected.
	Open the diagnostic screen of the EDS modules.

Allocating the Addresses for the EDS Modules

For the sprayer ECU to be able to properly switch the pneumatic valves, every EDS module must have a clear address.

You must allocate the addresses in the following cases:

- With the first configuration
- When replacing an EDS module

To allocate the addresses for the EDS modules:

Before you begin, make sure you have properly connected all of the components.

1. Open the start screen of the “EDS” application.

2.  - Start the address allocation.

The individual EDS modules are counted during the address allocation.

The EDS modules on the left side of the boom are counted first, then the EDS modules on the right side of the boom.

The address allocation is finished if there is no error message after it.

Testing the Configuration - “Demo” Function

Once you have allocated the addresses for the EDS modules, you can test whether all of the nozzles are switched properly and in the correct sequence.

You can test the nozzles automatically or manually.

To test the nozzles automatically:

1. Open the start screen of the “EDS” application.

2.  - Open the “EDS / Manual mode” screen.

The following screen appears:

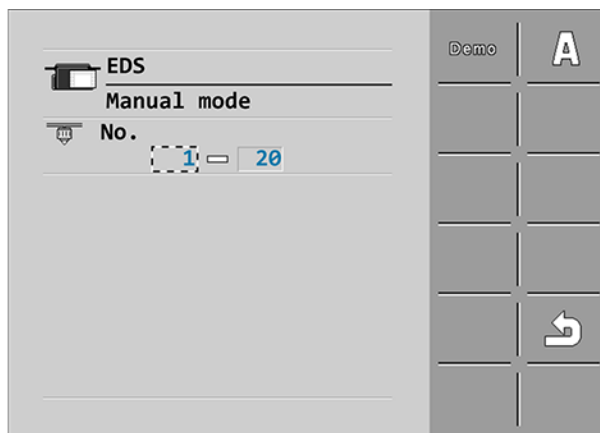

3.  - Activate the demo function.

The nozzles will be opened successively from left to right.

4. Check if the nozzles are opened in the correct sequence. If not, it is possible that valves were incorrectly rotated.
5. Or: Use A, B, C, D to switch the desired valves.

Configuring the Power Supply of the EDS Modules



If there are problems with the power supply, you can set the voltage with which the valves of the EDS modules are switched and operated.

The following parameters are used for this purpose:

- **Switch-on voltage** - The valves in each EDS module are switched on with this voltage.
- **Hold-on voltage** - After the switch-on time has expired, the valves will be supplied with this voltage.
- **Switch-on duration** - After this time following switching, the voltage changes from the “Switch-on Voltage” to the “Hold-on Voltage”.
- **Group delay** - This parameter describes the delay with which the valves are successively switched.
 - As a standard 0 ms
 - If the modules do not switch on reliably, you can increase this value to 10 or 20ms.
 - Booms with 72 modules (36 m working width) require 20 ms group delay.
 - For the voltage supply, the following default values as well as minimum and maximum values apply.

Parameter	Default value	Minimum value	Maximum value
Switch-on voltage	9 V	8 V	12 V
Hold-on voltage	3.4 V	3 V	12 V
Switch-on duration	20 ms	15 ms	100 ms
Group delay	0 ms	0 ms	100 ms

During start-up, the default values must be set as initial values by the master control unit of the field sprayer.

Function Icon	Meaning
	Saves the settings.
	Loads the factory default settings.

1. Open the ECU application.
2. On the work screen, press:



The following screen appears:

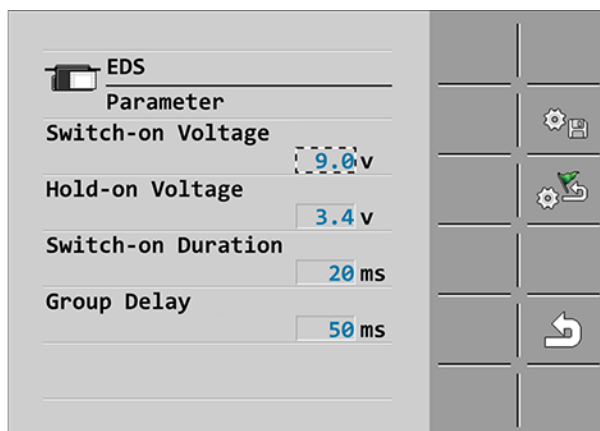

3. Set the parameters.

4.  - Optionally restore the standard values.

5.  - Transmit the settings to the EDS modules.

The following message appears: **“The parameters have been transmitted to the modules.”**

6. Confirm the alarm message.

You have configured the power supply of the EDS modules.

Configuring SECTION-Control for EDS

Configure the following parameter in the SECTION-Control application:

- **“Overlapping nozzles (EDS)”**

Activate parameter.

A description of this parameter can be found in the TRACK-Leader operating instructions.

Configure the following parameters in the geometry of the ECU application:

- **“Delay on start” and “Delay on stop”**

Because the field sprayer does not have any section valves and the nozzles cannot be directly controlled, the standard value is not current.

1. On the work screen, press:



2. The **“SECTION-Control”** screen appears:

3. Enter the determined delay times under **“Delay on start”** and **“Delay on stop”**.

Vario and Select Mode - Configuring Multiple Nozzle Holders

The ECU enables simultaneous use of several nozzles that are mounted on a multiple nozzle holder. This enables spraying with a constant drop size even when the speed changes.

Mode of operation

The faster the field sprayer is driving, the greater the pressure required in the nozzles to maintain the planned application rate. This makes the drops continuously smaller until the nozzles must be changed. The driver of a field sprayer without Vario-Select must therefore maintain the optimal speed for the mounted nozzles.

The Vario and Select operating modes allow the driver to change the nozzles without interrupting work.

- “Select” is used to manually activate the desired nozzles.

- “Vario” changes the nozzles automatically as soon as the speed makes it necessary. In doing so, this version can even activate several nozzles simultaneously to ensure optimum pressure and drop size at any speed.

Licenses

The mode is defined by the field sprayer manufacturer.

- Systems that only have Select activated can only control double nozzle holders.
- Systems with a Vario license can control double and quadruple nozzle holders. Furthermore, these systems also enable manual switching in Select mode. A Vario license can be purchased.

Path

Multiple nozzle holders are configured on the “MULTI NOZZLES” screen. To reach this screen:



Controls

Function icon	Function
	Manual activation of nozzles 1-4
	Serves to exclude nozzles 1-4 from the Vario mode.
	Activates the nozzle properties. Enables the calculation of possible application rates and working speeds.
	Changes the view between the application rate calculation and the working speed calculation.
	Activates the display of the flow rates of selected nozzles.
	Activates Vario mode when Select mode is active.
	Activates and deactivates nozzle cleaning.

Before You Buy Nozzles - Check the Possible Application Rates

To ensure that infinitely variable nozzle switching in Vario mode is possible, the flow rates of the mounted nozzles must overlap. This means that it must be possible to select the fitting nozzle for any pressure. At the



same time, the nozzles must be selected such that they allow for all of the application rates that should be sprayed with the field sprayer.

When selecting the nozzles, observe the following:

- In Vario mode, the ECU must be capable of activating each individual nozzle and each nozzle combination.
- The nozzle selection influences the possible application rates and working speeds. These three parameters must be coordinated to be able to use the Vario function.
- In Vario mode, all application rates in the following range must be possible: from the lowest application rate when using the smallest nozzle at the lowest pressure, up to the highest application rate when simultaneously switching all nozzles at the highest pressure.

There is a graph in the application of the ECU to help you with the nozzle selection. The graph shows the flow rates of selected nozzles. You can therefore check every nozzle combination before ordering the nozzles.

To find out whether the planned nozzle combination is correct:

1. Activate Vario mode.
2. Set the desired nozzles on the "MULTI NOZZLES" screen.
3.  - Activate the nozzle assistant.
4. Enter the intended pressure range and working speed in the nozzle assistant.
5.  - Display possible application rates. You will find explanations on the display in the images under this instruction.
6. Only install nozzles that have been successfully tested by the ECU and for which there have been no error messages during the configuration.

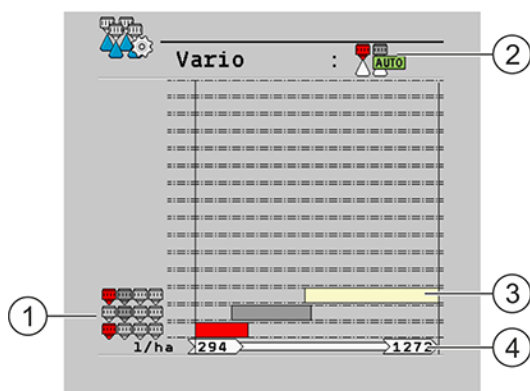

Possible nozzle ranges for nozzles are red and grey, in the pressure range from 2 bar to 6 bar

Item	Description	Item	Description
1	Here, you can see the nozzle combination for which the bar applies.	3	Bar with the desired application rate. The bar always begins at the lowest pressure and ends at the highest.
2	Current status of the function. Here: Vario mode is activated.	4	Minimum and maximum target rate for all nozzle combinations.

If some application rates are not possible for a nozzle combination, the display flashes red/yellow:

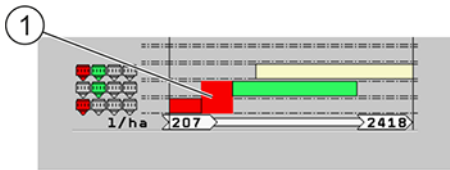

Possible nozzle ranges for nozzles are red and green, in the pressure range from 1 bar to 6 bar

Item	Description
1	The display flashes yellow/red. Application rates in the flashing range cannot be achieved with the selected nozzles.

In many cases, 3 nozzles are used for crop protection in Vario mode, the fourth nozzle is excluded from the Vario mode and is only activated manually for liquid fertilizer application.

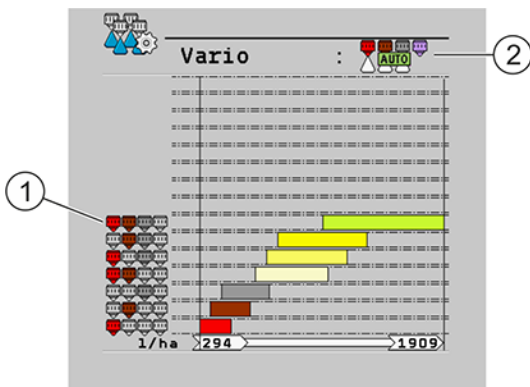

Vario with a quadruple nozzle holder. The purple nozzle is excluded.

Item	Description
1	Application rates are calculated without taking account of the purple nozzle.
2	Purple nozzle is excluded from the Vario.

In Select mode, the possible application rates are also displayed, but it is not necessary to use a combination without overlap.

Vario Mode - Automatic Nozzle Selection

In Vario mode, the system automatically activates one or several of the installed nozzles to achieve the defined drop size.

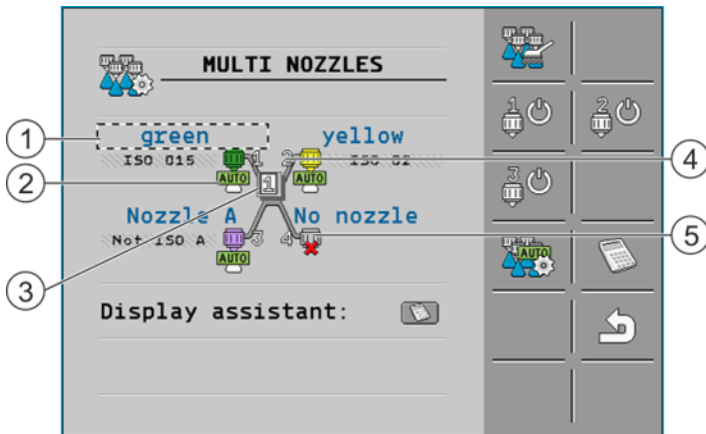

“MULTI NOZZLES” screen in Vario mode

Item	Description	Item	Description
1	Nozzle designation Most nozzles in the list are configured. Non-standard nozzles A, B, C, D can be calibrated.	4	Position of the nozzles on the nozzle holder. Make sure that the nozzles are mounted in the right position on each nozzle holder.
2	Nozzle status See the table below	5	Nozzle carrier without nozzles
3	Currently selected nozzle set Two nozzle sets are possible, each with up to 4 nozzles.		

Possible nozzle status - multi-nozzles screen

Icon	Description	Icon	Description
	Nozzle is automatically switched		Vario mode is deactivated. This nozzle is activated.
	No nozzle mounted on the nozzle carrier		Vario mode is deactivated. This nozzle is deactivated.
	Nozzle excluded from Vario mode		

A group of icons appears on the work screen, showing the status of each individual nozzle on the nozzle holder.

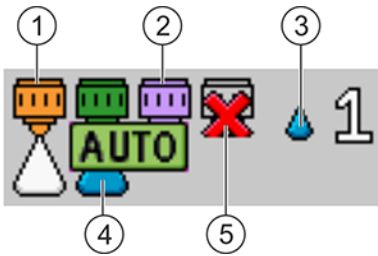

Nozzle status on the work screen

Item	Description	Item	Description
1	Orange nozzle is not applying.	4	Green nozzle is applying.
2	Nozzle excluded from Vario mode	5	No nozzle mounted on carrier no. 4.
3	Desired drop size		

To activate Vario mode:

1. Open the "MULTI NOZZLES" screen.



2. - Activate Vario mode.

"AUTO" appears underneath the nozzles.

The "Vario strategy, number of combinations" parameter appears. You can set the possible nozzle combinations with this parameter.

Select Mode - Manual Nozzle Selection

In Select mode, you can select the nozzles manually. The nozzles remain active until they are either manually deactivated or until Vario mode is activated.

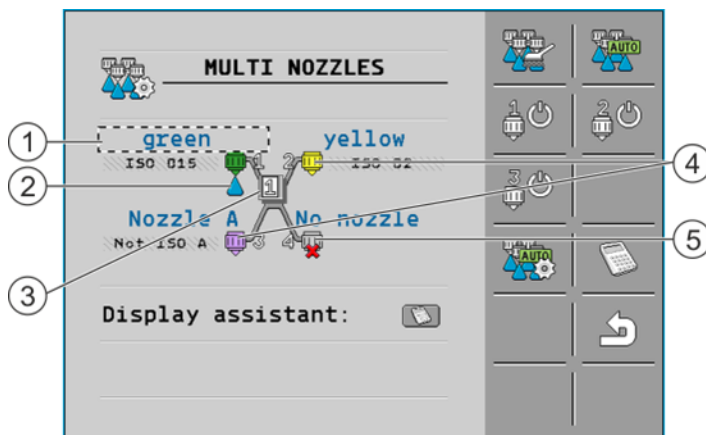

"MULTI NOZZLES" screen in Select mode

Item	Description	Item	Description
1	Cursor	4	Nozzles 2 and 3 are not activated during application.
2	Spray cone under the nozzle selected for the application	5	No nozzle mounted on carrier no. 4.

Item	Description	Item	Description
3	Currently selected nozzle set Two nozzle sets are possible, each with up to 4 nozzles.		

To activate and deactivate the nozzles manually:

1.  to  - Activate the desired nozzle.

A spray cone appears under the icon for the nozzle in the middle of the screen. This nozzle is now activated.

Select mode will be activated. The nozzles will no longer be automatically selected.

The  function icon appears.

The Select mode will be terminated as soon as you activate Vario mode or deactivate the nozzles manually.

Configuring the Nozzles on the Multiple Nozzle Holder

You can individually configure each nozzle on the multiple nozzle holder.

In doing so, you can:

- Select mounted nozzles from a list
- Calibrate the nozzles

Selecting the Type of Nozzle

You can select among 14 ISO-compliant nozzles and four non-ISO-compliant nozzles. If you use nozzles that do not fulfil ISO standard 10625, you can select nozzles A, B, C or D from the list. However, these nozzles must be calibrated.

Nozzles, colors and flow rate according to ISO 10625

Nozzle color in accordance with ISO 10625	ISO identifier	Output in l/min. at 3 bar
light violet	0050	0.2
Light pink	0075	0.3
Orange	01	0.4
Green	015	0.6
Yellow	02	0.8
violet	025	1.0
Blue	03	1.2
purple	035	1.4
Red	04	1.6
Brown	05	2.0
Gray	06	2.4

Nozzle color in accordance with ISO 10625	ISO identifier	Output in l/min. at 3 bar
White	08	3.2
Light blue	10	4.0
Light green	15	6.0
Nozzle A	-	Specific
Nozzle B	-	Specific
Nozzle C	-	Specific
Nozzle D	-	Specific

Before you begin, make sure the “MULTI NOZZLES” screen is called up.

1. Select the nozzle on the screen.
A list of nozzle colors appears.
2. Select installed nozzle.
The selected nozzle appears on the “MULTI NOZZLES” screen.

Calibrate the Nozzles

If you install a non-ISO-compliant nozzle, or if you notice that your nozzles perform differently than stipulated under ISO norms, you can re-calibrate the nozzles.

Before you begin, make sure you have selected the nozzle to be calibrated.



1.  - Call up the nozzle configuration
2. Enter the nozzle parameter. You can read these parameters either in the documentation from the nozzle manufacturer, or determine them yourself.

The calibration procedure is similar to systems without multiple nozzle holders.

Setting the Drop Size

In Vario mode, you can adjust the drop size. Depending on the field sprayer model, there can be 4 to 9 adjustable drop sizes.

Mode of operation

In Vario mode, the drop size is controlled through the pressure range that is set on the MULTI NOZZLES screen. The software tries to constantly maintain the system in a narrow pressure range that is in the middle of the pressure range defined for the nozzles.

- To increase the size of the drops, the pressure is reduced or the next possible nozzle is activated, which produces larger drops at the given pressure.
- To produce smaller drops, the pressure is increased on a nozzle or a smaller nozzle is activated, which produces smaller drops at the given pressure.

Before you begin, make sure:

- The pressure must remain constant.
- You have configured the nozzles.
- The sprayer is moving and applying.

To change the drop size in Vario mode:

1. Call up additional function icons:



2.  - Set the desired drop size.

The set drop size appears on the work screen.

The system selects the appropriate nozzle combination.

Deactivating Nozzles

You can only deactivate nozzles on a quadruple nozzle holder.

The following options are available to you:

- You can deactivate a nozzle globally.
- You can also exclude a nozzle in Vario mode.

Deactivating Nozzles Globally

Deactivate nozzles in this way if you are using a nozzle holder that is not fully equipped.

Before you begin, make sure:

- The nozzle is installed on a quadruple nozzle holder.
- The "MULTI NOZZLES" screen is called up.

1. Use the cursor to select the nozzle to be deactivated.

A list of nozzle colors appears.

2. Select "No nozzle".





Excluding Nozzles from Vario Mode

You can also exclude a nozzle from Vario mode. The excluded nozzles can only be activated in Select mode or in cleaning mode.

In this way, for example, you can use the nozzle deactivated in Vario mode for the application of liquid fertilizer in Select mode. The remaining 3 nozzles remain available for normal spraying in Vario mode.

Before you begin, make sure:

- The nozzle is installed on a quadruple nozzle holder.
- The "MULTI NOZZLES" screen is called up.

1.  - Press.
2.  to  - Select the nozzle to be excluded.
3. The excluded nozzle will be marked as follows: 

Configuring CURVE-Control

If you are using an implement with double or quadruple nozzle holders, you can use CURVE-Control to adapt the lateral distribution when driving in curves. This compensates for different speeds across the boom.

Before you begin, make sure you have configured the nozzles.

1. Switch to the "SECTION RATE CONTR." screen:



2. Activate the "Rate compensation in curve active" parameter.
3. Enter the maximum curve radius for your implement.

You have activated CURVE-Control.

On the work screen, the following icon will now be shown:





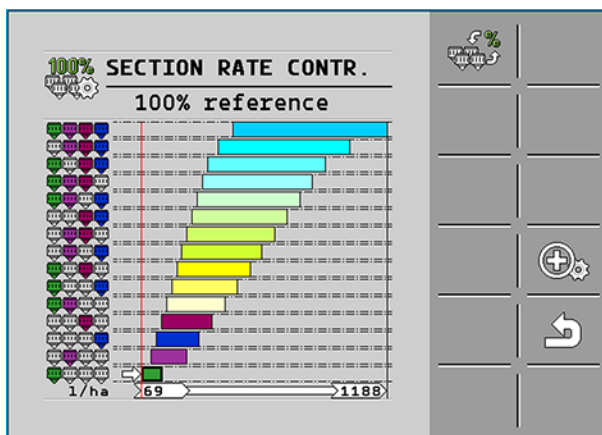

4.  - View the current application rate for the individual nozzles.

The following screen appears:



You can see the application rate for the individual nozzles.

5.  - View optional percent values.

6.  - View target rate and current speed.
7. Change the optional target rate.
8.  - Return to the display of the current application rate.
9.  - Return to the configuration screen.
10.  - Optionally view the target rate deviation for each individual section.

Parameter	Description
Rate compensation in curve active	Activate this parameter to activate CURVE-Control.
Max. Curve Radius	Enter the maximum curve radius for your implement.
Nozzle Control by Sensors	Activate this parameter if your implement is equipped with nozzles that are controlled by sensors.
Nozzle Control by 'TC-GEO	Activate this parameter if your implement is equipped with nozzles that are controlled by TC-GEO.



Troubleshooting EDS

The communication module can check the status of the EDS modules and make it easier to diagnose errors.

You can perform the following actions to search for errors:

- View system detected errors
- View different information about individual EDS modules

Controls

Function icon	Meaning
	Indicates the EDS modules on which errors were detected.
	Open the diagnostic screen of the EDS modules.

Search for Faulty EDS Modules

To search for faulty EDS modules.

1. Open the start screen of the “**EDS**” application.

2.  - Open the error display screen.

You see which modules have reported which errors.

3.  - Optionally delete the displayed error list.

Using the Diagnostic Function of the EDS Modules

You can use a diagnostic function for the individual EDS modules.

1. Open the start screen of the “**EDS**” application.



2. - Open the diagnostic screen.

The “EDS / Diagnostics” screen appears.

3. Use the parameter “No.” to select for which EDS module you want to see the diagnostic values.

The diagnostic values for the selected module are shown.

The following diagnostic values are available:

- **Voltage Electronic (VE)** - The currently measured voltage.
- **Voltage Power (VL)** - The currently measured voltage.
- **Outputs** - Is the respective output is switched on or off.
- **Software version** - The current software version on the EDS modules.

After a Module Change

After replacing an EDS module, reallocate the addresses for the EDS modules.

Troubleshooting

- Checking the Software Version
- Diagnostic
- Checking the Measured Values for the Connection Pin
- Importing and Exporting Files
- Managing the Error Memory
- Displaying the ECU Information
- Configuring the Factory Parameters

Checking the Software Version

To find out the software version:

1. Switch to the “Parameters” screen:



The software version will be shown.

Diagnostic

Menus and diagnostic options

Function Icon	Meaning
	Hardware diagnostics Shows the configuration and status of all pins of the ECU. This makes it possible to detect faulty sensors and actuators.
	Managing the configuration data Makes it possible to export or import entire implement configurations.
	Error memory Makes it possible to view and export software errors and error protocols.
	Job computer information Shows various information about the ECU.
	Factory parameters Make it possible to change the factory parameters through the terminal.

Before you begin, make sure you have entered the user and service password.

1. Change to the “Diagnostics” screen:









The “Diagnostic” screen appears.

2. Now select what you want to do next.

Checking the Measured Values for the Connection Pin

On the “Connections” screen, you can:

- Check the configuration of a pin.
- Check the voltage of a pin.
- Read the voltage and evaluate it in terms of the configuration and software application.

Function Icon	Function
	Shows the previous pins.
	Shows the next pins.
	Filters the displayed pins.
	Deactivates the filter.
	Changes to the function view. The function that is assigned to the respective pin is shown.
	Changes to the measured values view. The measured values on the respective pin are shown.

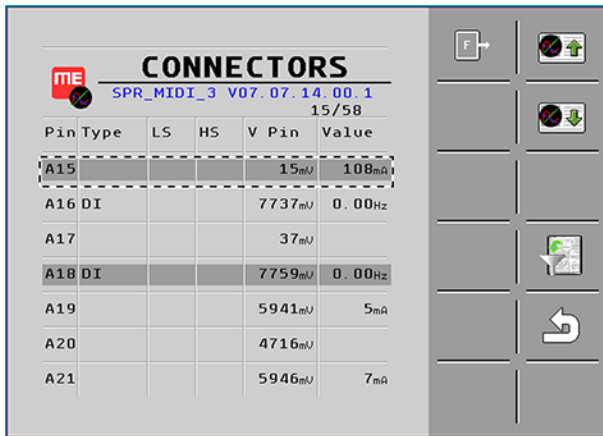

"Connections" screen

On the "Connections" screen, you can view the following values:

Column	Explanation
Pin	Pin number
Type	Configured output or input type.
LS and HS	Both columns serve to see the status of specific outputs (LS, HS, bridge).
U pin	Current voltage on the pin.
Value	Result of a pin measurement with units.

1. On the "Diagnostics" screen, press:





The "Connections" screen appears.

2. Check the measured values.

To reduce the number of displayed pins:

Before you begin, make sure the "Connections" screen has been called up.





1. Touch the line in the table.
2. The line will be marked in grey.
3. Mark multiple lines. You can select up to seven lines.
4.  - Press to hide all of the lines that are not marked.
5.  - Press to deactivate the filter.

Importing and Exporting Files

You can export or import files from the ECU. There are three different ways to do this:

- Importing the configuration from the FILE-Server
- Exporting the configuration to the FILE-Server
- Loading the configuration from the internal memory of the ECU



Sub-menus on the "Configuration file" screen

Function Icon	Function
	Exports the configuration to the FILE server of the terminal.
	Imports a configuration from the FILE server of the terminal.
	Creates a copy of the current configuration on the FILE server as a cfg file.
	Imports a configuration from the internal memory of the ECU.

Importing a Configuration File from the FILE-Server

If the configuration saved on the FILE server has the correct manufacturer ID, it can be imported.

Operating elements on the "FILES" screen

Function Icon	Function
	Imports the marked configuration from the FILE server of the terminal.
	Updates the list.
	Previous page.

Function Icon	Function
	Next page.

File Types

Based on the file name, you can see the purpose and age of the file.

The date and time of saving of the configuration can be seen under the file name.

The file with "save_01" in its name is rewritten every day when the system is started for the first time. It contains the current configuration of the day.

To import a configuration:

1. On the "Diagnostics" screen, press:



The "Configuration file" screen appears.

2.  - Press to import a configuration.

The "Files" screen appears.

All of the configuration files saved on the FILE server will be shown:





3. Select and mark a file.

4.  - Import the file.

The system checks whether the configuration file to be loaded meets the minimum requirements of the system.

5. **NOTICE! When you import the configuration, all of the previous settings will be overwritten by the new configuration.**

6.  - Import the configuration.

7.  - Cancel import.

The configuration will be imported or canceled.

If the import is not possible, an error message appears.

Exporting a Configuration File to the FILE-Server

If you connect a terminal with the "FILE server" plug-in to the ISOBUS, you can save the current configuration to the FILE server.

Configurations are saved in the following cases:

- Daily, when the system is started for the first time. Automatic saving.
- When you export the configuration manually.

To export a configuration:

1. On the "Diagnostics" screen, press:



The "Configuration file" screen appears.

2.  - Press.

The current configuration will be saved to the FILE-Server.

The further procedure depends on your terminal. On PTx terminals, you can move the files from the FILE server to a USB memory device. Read the terminal instructions for more information.

Loading the Configuration from the Internal Memory of the ECU

The ECU has a small internal memory, in which copies of configurations are saved. This is always done when a configuration is written to the ECU via the FILE server or the SPRAYER-Configurator.

This allows old configurations (e.g. with factory settings) to be restored on terminals without a FILE server.

With this method, changes made by the user are not saved.

To restore a configuration:

1. On the "Diagnostics" screen, press:



The "Save config." screen appears.

2. A list with saved configurations and with their date of creation appears.

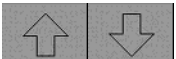
3.  - Select a configuration.

-  - Load the configuration shown on the screen.

You will be asked whether you want to load the file.







-  - Import the configuration.

-  - Cancel import.

The configuration will be imported or canceled.

Managing the Error Memory

The ECU records all crashes and errors that it discovers since its initial operation.

Function Icon	Function
	Exports the error protocol to the FILE server.
	Shows the error memory.
	Exports the selected error protocol to the FILE server.
	When pressed longer, clears the error memory.
	Previous page.
	Next page.

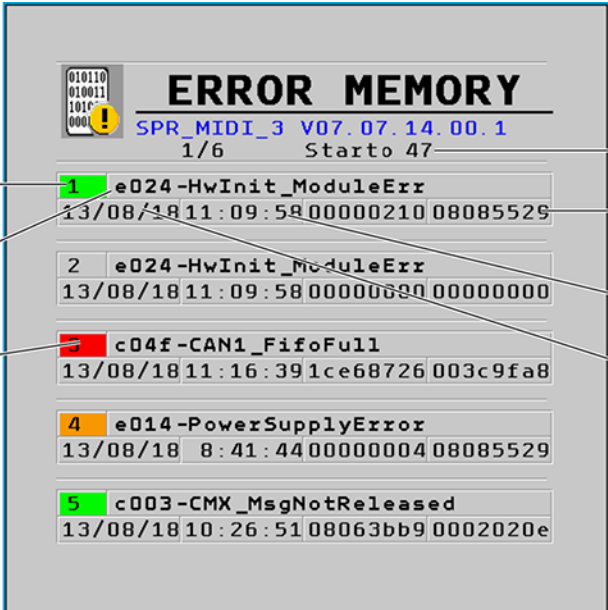





The screenshot shows the 'ERROR MEMORY' screen with the following details:

- 1**: Points to the error ID '1'.
- 2**: Points to the error description 'e024-HwInit_ModuleErr'.
- 3**: Points to the error description 'c04f-CAN1_FifoFull'.
- 4**: Points to the error ID '4'.
- 5**: Points to the timestamp '13/08/18 11:09:58'.
- 6**: Points to the error description 'e014-PowerSupplyError'.
- 7**: Points to the error description 'c003-CMX_MsgNotReleased'.

Additional screen content includes: '010110 010011 101010 0001' with a warning icon, 'SPR_MIDI_3 V07.07.14.00.1', '1/6 Starto 47', and a list of error entries with their respective IDs, descriptions, and timestamps.

The "Error memory" screen appears.

Item	Description	Item	Description
1	Error number	4	Start number of the application
2	Error description	5	Memory information
3	Status:  - The error occurred for the first time in the current session. If you fix the error, it will be marked in orange after a restart.  - The error occurred for the first time before the last restart of the system, and still has not been fixed.  - Error fixed.  - The error was detected in the past. However, it is currently not possible to determine its status.	6	Time at the first occurrence
		7	Date at the first occurrence

When you select an error, detailed information will be shown:

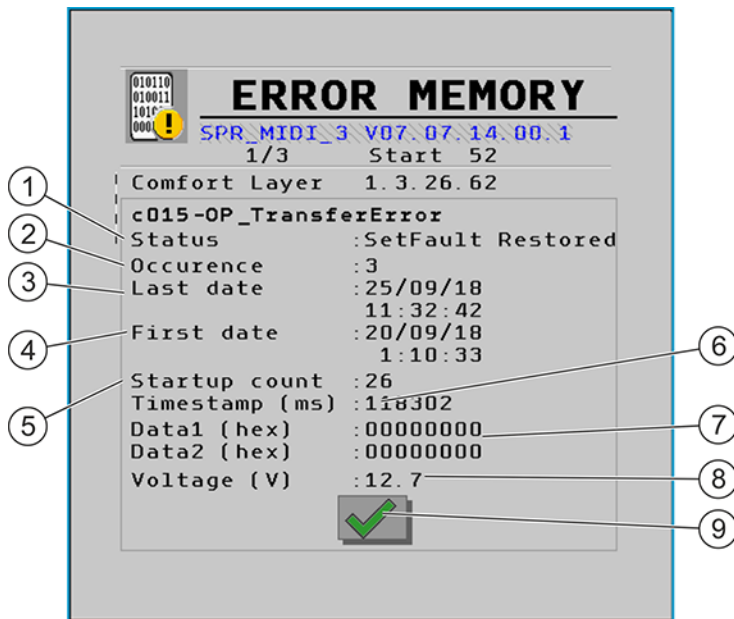

Error description

Item	Description	Item	Description
1	Error status	6	Time from the system start until the error
2	Frequency	7	Memory data
3	Last occurrence	8	Voltage
4	First occurrence	9	Function icon for confirmation
5	With system start number...		

To access the "Error memory" screen:

1. On the "Diagnostics" screen, press:



The "Error memory" screen appears.

2.  - Show error.

All recorded errors will be shown.

Displaying the ECU Information

You can display various information about your ECU.

1. On the "Diagnostics" screen, press:



Various information about the ECU will be displayed.

Configuring the Factory Parameters

You can change the factory parameters through the terminal. You can also change the configuration without the Configurator.

Only make changes here if you have professional knowledge of the configuration and functioning of the implement.

1. On the "Diagnostics" screen, press:



2. Select the desired function.
3. Make the desired change.

Technical Specifications

- ECU-MIDI 3.0 Technical Specifications
- 42-Pin General Information
- 42-Pin Connector Assignment
- 16-Pin IN Connector Pin Assignment
- 16-Pin OUT Connector Pin Assignment
- Junction Box
- DISTANCE-Control
- DISTANCE-Control II
- EDS Module
- Available Languages

ECU-MIDI 3.0 Technical Specifications

Specification	Description
1. processor:	32-bit ARM Cortex™-M4 CPU 168 MHz, 2048 KB flash; 256 KB RAM
2. processor:	32-bit ARM Cortex™-M4 CPU 168 MHz, 2048 KB flash; 256 KB RAM
External memory:	SPI-Flash 16 MB; SDRAM 16 MB; FRAM 16 kByte
Connections:	<ul style="list-style-type: none"> ▪ 42-pin connector for connecting actuators/sensors ▪ 2x 16-pin connector for power supply and CAN The connectors can be locked and equipped with single conductor insulation.
Interfaces:	up to 3xCAN*
Power supply:	12 V electrical system (9-16 V), maximum current consumption 30 A
Current consumption (IN):	500 mA (at 14.4 V without power output, without supply to external sensors)
Standby current (OFF):	70 µA (typ.)
Temperature range:	-40 ... +70 °C
Housing:	Anodized aluminum continuous cast casing, plastic lid with seal and pressure compensation element, stainless steel screws
Protection rating:	IP6K6K (with installed connectors)
Environmental tests:	Vibration and shock testing in accordance with DIN EN 60068-2 Temperature testing in accordance with IEC68-2-14-Nb, IEC68-2-30 and IEC68-2-14Na Protection testing in accordance with DIN EN 60529 Electromagnetic compatibility according to DIN EN ISO 14982: 2009-12
Dimensions:	Approx. 262 mm x 148 mm x 62 mm (L x W x H, without connector)
Weight:	ca. 1 kg

42-Pin General Information

Detail	Description
Outputs	<ul style="list-style-type: none"> • 2x Trigger output (Lowside up to 25 mA) • 14x High- and/or Lowside 4 A* (Highsides are PWM capable, thereof max. 6 with current measurement), the maximum PWM frequency of the 4 A outputs is 500 Hz • 2x Highside 4 A* • 1x Highside for sensor supply up to 4 A* • 2x Half bridge* for 12 A* servo motors or PWM operation of DC motors • 2x Half bridge* for 10 A* servo motors or PWM operation of DC motors • PWM up to 16 kHz at d= 10% - 90% @resistive load

Detail	Description
Inputs:	Up to 23 universal inputs in total, configurable as: <ul style="list-style-type: none"> • 17x Analog 0 – 5 V • 23x Analog 0 – 10 V • 23x NPN sensors (of which max. 17x rotational speed) • 23x PNP sensors (of which max. 8x rotational speed) • 14x 4 – 20 mA power input (of which max. 8x rotational speed / max. 4 with a burden < 50 Ohm) • 12x Namur sensors
Interfaces:	Upon request: CAN, LIN

The values are based on $T_u = 25^\circ \text{C}$. At higher temperatures the load capacity is reduced.

42-Pin Connector Assignment

Pin	Analog 0-5 V	Analog 0-10 V	Analog 4 – 20 mA	Namur	Digital static pull-up	Digital static pull-down	Digital rotational speed pull-up	Digital rotational speed pull-down	rotational speed 4 – 20 mA	type of output	Max. continuous current	PWM (with 4 A outputs only HS)	Capable for diagnosis	Special functions
1	12 VL									-	12 A	-	x	-
2	x	x	x	-	x	-	x	-	-	OC	25 mA	-	x	-
3	x	x	x	-	x	-	x	-	-	OC	25 mA	-	x	(LIN)
4	x	x	x	-	x	-	x	-	-	-	-	-	x	(5V_S)
5	-	-	-	-	-	-	-	-	-	HS+LS	10 A*	16 kHz, 10-90 %	x	(cs_ext.)
6	-	(x)	-	-	(x)	-	-	-	-	HS+LS	4 A*	500 Hz, 10-90 %	x	-
7	-	-	-	-	-	-	-	-	-	HS+LS	10 A*	16 kHz, 10-90 %	x	(cs_ext.)
8	-	-	-	-	-	-	-	-	-	HS+LS	4 A*	500 Hz, 10-90 %	x	cs_ext.
9	-	-	-	-	-	-	-	-	-	HS+LS	4 A*	500 Hz, 10-90 %	x	cs_ext.
10	-	-	-	-	-	-	-	-	-	HS+LS	4 A*	500 Hz, 10-90 %	x	cs_ext.
11	-	-	-	-	-	-	-	-	-	HS+LS	4 A*	500 Hz, 10-90 %	x	-
12	-	-	-	-	-	-	-	-	-	HS+LS	4 A*	500 Hz, 10-90 %	x	-
13	-	(x)	-	-	(x)	-	-	-	-	HS	4A*	-	x	-
14	x	x	-	x	x	-	x	-	-	-	-	-	x	-
15	-	-	-	-	-	-	-	-	-	HS+LS	12 A*	16 kHz, 10-90 %	x	cs_ext.
16	x	x	-	x	x	-	x	-	-	-	-	-	x	(LIN)
17	x	x	x	-	x	-	x	-	-	-	-	LOW_R	x	(CAN2_L)
18	x	x	x	-	x	-	x	-	-	-	-	LOW_R	x	(CAN2_H)
19	-	-	-	-	-	-	-	-	-	HS+LS	4 A*	500 Hz, 10-90 %	x	cs_ext.
20	-	(x)	-	-	(x)	-	-	-	-	HS+LS	4 A*	500 Hz, 10-90 %	x	-
21	-	-	-	-	-	-	-	-	-	HS+LS	4 A*	500 Hz, 10-90 %	x	cs_ext.
22	-	-	-	-	-	-	-	-	-	HS+LS	4 A*	500 Hz, 10-90 %	x	cs_ext.
23	-	(x)	-	-	(x)	-	-	-	-	HS+LS	4 A*	500 Hz, 10-90 %	x	-

Pin	Analog 0-5 V	Analog 0-10 V	Analog 4 – 20 mA	Namur	Digital static pull-up	Digital static pull-down	Digital rotational speed pull-up	Digital rotational speed pull-down	rotational speed 4 – 20 mA	type of output	Max. continuous current	PWM (with 4 A outputs only HS)	Capable for diagnosis	Special functions
24	-	(x)	-	-	(x)	-	-	-	-	HS+LS	4 A*	500 Hz, 10-90 %	x	-
25	-	-	-	-	-	-	-	-	-	HS+LS	4 A*	500 Hz, 10-90 %	x	-
26	-	-	-	-	-	-	-	-	-	HS+LS	4 A*	500 Hz, 10-90 %	x	-
27	-	(x)	-	-	(x)	-	-	-	-	HS	4 A*	-	x	(8V2_S)
28	-	-	-	-	-	-	-	-	-	HS+LS	12 A*	16 kHz, 10-90 %	x	cs_ext., GNDL
29	12 VL									-	12 A	-	x	-
30	x	x	-	x	x	-	x	-	-	-	-	-	x	-
31	x	x	x	x	x	-	x	-	-	-	-	-	x	-
32	12 V Sensor									-	4 A*	-	x	-
33	GND Logic									-	10 A*	-	-	-
34	x	x	x	x	x	x	x	x	x	-	-	-	x	-
35	x	x	x	x	x	x	x	x	x	-	-	-	x	-
36	x	x	x	x	x	x	x	x	x	-	-	-	x	-
37	x	x	x	x	x	x	x	x	x	-	-	-	x	-
38	x	x	x	(x)	x	x	x	x	x	-	-	-	x	-
39	x	x	x	(x)	x	x	x	x	x	-	-	-	x	-
40	x	x	x	(x)	x	x	x	x	x	-	-	LOW_R	x	-
41	x	x	x	(x)	x	x	x	x	x	-	-	LOW_R	x	-
42	GND Power									-	12 A	-	-	-

x = provided, (x) = optional or limited available, cs = current sense, OC = open collector; LOW_R = Input with low load

* The values are based on Tu = 25 °C. At higher temperatures the load capacity is reduced.

** Diagnostics

The inputs and outputs of the 42-pin connector are short circuit-proof against supply voltage and ground, except for GND electronics (GNDE) and GND power (GNDL) against supply voltage and 12 VL (pin 1 and 29) against ground.

16-Pin IN Connector Pin Assignment

Pin	Analog 0-5 V	Analog 0-10 V	Analog 4 – 20 mA	Namur	Digital static pull-up	Digital static pull-down	Digital rotational speed pull-up	Digital rotational speed pull-down	rotational speed 0 – 20 mA	type of output	Max. continuous current	special function	Capable for diagnosis
1	x	-	-	-	x	-	x	-	-	-	-	connected to 16-pin OUT	x
2	CAN0_L									-	-	Active terminator can be actuated via the software	-
3	CAN_GND									-	-	TBC_RTN	-
4	GND Electronic									-	12 A*	connected to 16-pin OUT	-
5	GND Power									-	30 A	Internally bridged and connected to 16-pin OUT	-
6													
7													
8													
9	x	-	-	-	x	-	x	-	-	-	-	connected to 16-pin OUT	x
10	CAN0_H									-	-	Active terminator can be actuated via the software	-
11	CAN_EN									-	-	TBC_PWR	-
12	12 V electronics									-	12 A*	connected to 16-pin OUT	x
13	12 V power									-	30 A	Internally bridged and connected to 16-pin OUT	x
14													
15													
16													

* When connecting multiple ECUs in series, it must be considered that on the system level, the current conducted to the OUT connector is included in total load on the IN connector.

It must be ensured that the individual pins of the IN connector are not overloaded (e.g. due to insufficient fuses in the cable harness).

* The values are based on $T_u = 25^\circ \text{C}$. At higher temperatures the load capacity is reduced.

16-Pin OUT Connector Pin Assignment

Pin	Analog 0-5 V	Analog 0-10 V	Analog 4 – 20 mA	Namur	Digital static pull-up	Digital static pull-down	Digital rotational speed pull-up	Digital rotational speed pull-down	rotational speed 0 – 20 mA	type of output	Max. continuous current	special function	Capable for diagnosis
1	-	-	-	-	-	-	x	-	-	-	-	connected to 16-pin IN	x
2	CAN0_L or CAN1_L									-	-	Can be actuated via the software	-
3	CAN_GND									-	-	connected to GND	-
4	GND Electronic									-	12 A*	connected to 16-pin IN	-
5	GND Power									-	30 A	Internally bridged and connected to 16-pin IN	-
6													
7													
8													
9	-	-	-	-	-	-	x	-	-	-	-	connected to 16-pin IN	x
10	CAN0_H or CAN1_H									-	-	Can be actuated via the software	-
11	CAN_EN									-	50 mA	-	-
12	12 V electronics									-	12 A*	connected to 16-pin IN	x
13	12 V power									-	30 A	Internally bridged and connected to 16-pin IN	x
14													
15													
16													

* When connecting multiple ECUs in series, it must be considered that on the system level, the current conducted to the OUT connector is included in total load on the IN connector.

It must be ensured that the individual pins of the OUT connector are not overloaded (e.g. due to insufficient fuses in the cable harness).

* The values are based on $T_u = 25\text{ °C}$. At higher temperatures the load capacity is reduced.

Junction Box

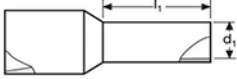
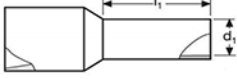
Specification	Description	
Dimensions (W x H x D):	220 mm x 81 mm x 120 mm	
Cable grommet:	20x M12 Skintop® connectors: Cable diameter 3.5 to 7 mm 16x M16 Skintop® connectors: Cable diameter 4.5 to 10 mm	
Connections:	42-pin AMP connector	
Actuator terminals*:	<p><i>Without wire end ferrule:</i></p> <p>Wire cross-section max. 2.5 mm², min. 0.2 mm²</p>	<p><i>With wire end ferrule:</i></p>  <p>$l_1=10\text{ mm}, d_1=2.5\text{ mm}^2$</p>
Sensor terminals*:	<p><i>With wire end ferrule:</i></p> <p>Wire cross-section max. 1 mm², min. 0.2 mm²</p>	<p><i>With wire end ferrule:</i></p>  <p>$l_1=8\text{ mm}, d_1=1\text{ mm}^2$</p>
Temperature range:	-20 ... +70 °C	
Protection class:	IP65	

* Release of the cable using the supplied tool to avoid damage to the terminals

DISTANCE-Control

Ultrasonic Sensors

Ultrasonic Sensor wms-340/RT/K1/MUE

Specification	Description
Power supply	9V - 30V DC
Blind zone	350mm
Maximum range	3400mm (in the system 3000mm)
Protection class according to EN 6052	IP67
Operating temperature	-20°C - +70°C

Ultrasonic Sensor 4-Pin Connector

Pin	Signal	Sensor Cable Colors	Explanation
1	12VE	brown	Power supply
2	Trigger	yellow	Control line impulse
3	GNDE	white	Ground
4	Echo	green	Control line echo

Angle Sensors

Angle Sensor Technical Specifications

Specification	Description
Power supply	10V - 30V DC
Measurement range	+/- 45°

Angle Sensor 3-Pin Connector

Pin	Designation
1	GNDE
2	12VE
3	Signal

Slope Sensor

Slope Sensor Technical Specifications

Specification	Description
Power supply	9V - 30V DC
Current consumption	50mA
Operating temperature	-40°C - +80°C
Protection class	IP65 IP67
Measurement range	+/- 45°
Output voltage	0,5V - 4,5V Lower limit: 0.48 V / Upper limit: 4.52V
Connection	1m cable, Superseal AMP connector

Slope Sensor 3-Pin AMP Connector

Pin	Cable color	Designation
1	blue	0 VE
2	brown	12 VE
3	white	Signal

DISTANCE-Control II

Ultrasonic Sensors

Ultrasonic Sensor wms-340/RT/K1/MUE

Specification	Description
Power supply	9V - 30V DC
Blind zone	350mm
Maximum range	3400mm (in the system 3000mm)
Protection class according to EN 6052	IP67
Operating temperature	-20°C - +70°C

Ultrasonic Sensor 4-Pin Connector

Pin	Signal	Sensor Cable Colors	Explanation
1	12VE	brown	Power supply
2	Trigger	yellow	Control line impulse
3	GNDE	white	Ground
4	Echo	green	Control line echo

Angle Sensors

Angle Sensor Technical Specifications

Specification	Description
Power supply	10V - 30V DC
Measurement range	+/- 45°

Angle Sensor 3-Pin Connector

Pin	Designation
1	GNDE
2	12VE
3	Signal

EDS Module

Technical Specifications of the EDS Modules

Specification	Description
Power supply	12 V DC electrical system (9...16 V)
Current consumption 12 VE	23 mA (with 12 V & listen only mode) 54 mA (with 12 V & CAN transmit)
Standby current consumption 12 VL	Typically 30 µA; max. 70 µA (with 12 VE = 0)
Current consumption 12 VL	2.6 mA (when outputs are switched off) Each of the 4 pneumatic valves (9 V coil with 66 Ω internal resistance) in the module requires a switch-on current of approx. 136 mA. In hold-on mode (PWM operation, for which the hold-on voltage is defined through the settings), the current consumption can be reduced to a minimum of approx. 23 mA with 3.4 V hold-on voltage and with 12 V electrical system. The maximum current consumption is approx. 540 mA, when all four valves are actuated and the „hold-on voltage“ parameter is configured at 9 V.
Protection class	IP66 (after installation)
Compressed air quality	According to ISO 8573-1:2010 [7:4:4], filtered at 40 µm, free of aggressive constituents
Compressed air temperature	-5°C - +50°C
Operating pressure	The air pressure must be adjusted to 5...8 bar. The maximum permitted pressure is 10 bar.
Pneumatic valves	3/2-way valve, 9 V DC / 1 W 100% ED Nominal width 0.8 mm (20 NI/min) FKM seal, 30 million switch cycles
Pneumatic connections	John Guest quick connector with an O-ring made of NBR 2x supply „1“: Plastic cartridge for 8 mm hose Outputs „A-D“: Plastic cartridge for 4 mm or 6 mm The pneumatic connections must be protected from direct water jets.
Other information	The pneumatic system must include a central pressure regulator with filter and a water separator.

Cable Harness Pin Assignment

Legend:

- **VL** – Power voltage. Voltage for supplying the actuators.
- **VE** – Electronics voltage. Voltage for supplying the electronics.

EDS Module Cable Pin Assignment

Pin	Signal	Pin	Signal	Pin	Signal
1	12VL	5	Address allocation	8	0 VL
2	0 VL	6	0 VE	9	12VL
3	CAN_H EDS-BUS	7	12VE	10	0 VL
4	CAN_L EDS-BUS				

Communication Module Pin Assignment

Pin	Signal	Pin	Signal	Pin	Signal	Pin	Signal
1		5	0 VL	9		13	12VL
2	CAN_L	6	0 VL	10	CAN_H	14	12VL
3	CAN_0 V	7	0 VL	11	CAN_EN	15	12VL
4	0 VE	8	0 VL	12	12VE	16	12VL

Available Languages

You can set the following languages in the software for the operation of the implement:

Bulgarian, Croatian, Czech, Danish, Dutch, English, Estonian, Finnish, French, German, Greek, Hungarian, Italian, Latvian, Lithuanian, Norwegian, Portuguese, Polish, Romanian, Russian, Serbian, Slovak, Slovenian, Spanish, Swedish, Turkish

Item Overview

- SPRAYER-Controller MIDI 3.0
- TRAIL-Control
- DISTANCE-Control
- DISTANCE-Control II
- SPRAYER-Controller MIDI 3.0
- EDS Module

SPRAYER-Controller MIDI 3.0

ISOBUS ECU with Expansion ECU for Sprayers

Designation	Item number
ISOBUS Sprayer Controller MIDI 3.0	3032245501
ECU-MIDI 3.0 sprayer ISOBUS ECU add-in ECU	3032245601
VARIO-Select activation for automatic nozzle selection	30303080
AIRTEC activation for droplet size control	30303075
AIRTEC II activation for droplet size control	30303078
Connector cable, ISOBUS ECU, 1 m	3030314303
Connector cable, ISOBUS ECU, 2.5 m	3030314603
Connector cable, ISOBUS ECU, 4 m	3030314403
Connector cable, ISOBUS ECU, 5.5 m	3030314803
Connector cable, ISOBUS ECU, 6.5 m	3030314003
Connector cable, ISOBUS ECU, 8.5 m	3030314203
Connector cable, ISOBUS ECU, 11 m	3030314103
Connector cable, ISOBUS ECU, 14 m	3030314703
Universal junction box for ECU-MIDI 3.0 , 0.6 m cable	3032247001
Universal junction box for ECU-MIDI 3.0 , 1.5 m cable	3032247501
Universal junction box for ECU-MIDI 3.0 , 2 m cable	3032247101
Universal junction box for ECU-MIDI 3.0 , 4 m cable	3032247201
Universal junction box for ECU-MIDI 3.0 , 6 m cable	3032247301

Accessories

Designation	Item number
Connector cable, main to expansion ECU, 0.3 m	30322355
Connector cable, main to expansion ECU, 1.5 m	30322359
Connector cable, main to expansion ECU, 3.2 m	30322358
Connector cable, main to expansion ECU, 6.5 m	30322357
Connector cable, main to expansion ECU, 10 m	30322356
Sensor X (speed), trailed sprayer, 1 m cable with AMP connector, 12 magnets	30303621
GPS speed sensor	30258330
Anemometer for sprayers, 3 m cable with 3-pin AMP connector	30303705

Designation	Item number
2 m connector cable for sensors, with 3-pin AMP socket to junction box	30303294

Flow Meter

Designation	Item number
Flow meter (Bürkert), Inline DN 20, 10 bar, 7 m cable without connector, 8 - 140 l/min	30244510
Flow meter (Bürkert), Inline DN 25, 10 bar, 7 m cable without connector, 14 - 220 l/min	30244710
Flow meter Polmac 1" Turbo-Flow 30 bar, 7 m cable without connector, 6 - 140 l/min	30244910

Pressure Sensor

Designation	Item number
Pressure sensor 0 - 16 bar, 1 m cable with AMP connector	30303591
8 m connector cable for sensors, with 3-pin AMP socket to junction box	30303297
Pressure sensor accessories bag	31243210

TRAIL-Control

Optional for ECU MIDI 3.0

Designation	Item number
Gyroscope with 2x bracket, with AMP connector	30303685
Angle sensor with AMP connector, without cable, with boom	30303015

Optional

Designation	Item number
Electronic slope sensor with 1 m cable and AMP connector	30303690
Proportional valve	302923

Connector Cable for Sensors and Gyroscope

Designation	Item number
Connector cable for sensors, 2 m with 3-pin AMP socket to junction box	30303294
Connector cable for sensors, 4 m with 3-pin AMP socket to junction box	30303296
Connector cable for sensors, 6 m with 3-pin AMP socket to junction box	30303295
Connector cable for sensors, 8 m with 3-pin AMP socket to junction box	30303297

DISTANCE-Control

ISOBUS DISTANCE-Control with 2 Ultrasonic Sensors, with 1 Slope Sensor

Designation	Item number
2 ultrasonic sensors	30303058
Connector cable, ultrasonic sensor, 20 m	
Accessory bag for DISTANCE-Control	
Angle sensor with AMP connector, without cable, with boom	
Electronic slope sensor with 1 m cable and AMP connector	

ISOBUS DISTANCE-Control with 2 Ultrasonic Sensors, with 2 Slope Sensors

Designation	Item number
2 ultrasonic sensors	30303059
Connector cable, ultrasonic sensor, 20 m	
Accessories bag for boom control	
Angle sensor with AMP connector, without cable, with boom	
Electronic slope sensor with 1 m cable and AMP connector	

DISTANCE-Control II

Designation	Item number
DISTANCE-Control II ECU	3030316501
Connector cable, main to expansion ECU, 0.3 m	30322355
Connector cable, main to expansion ECU, 1.5 m	30322359
Connector cable, main to expansion ECU, 3.2 m	30322358
Connector cable, main to expansion ECU, 6.5 m	30322357
Connector cable, main to expansion ECU, 10 m	30322356
Ultrasonic sensor for boom control	30217518
Connector cable, ultrasonic sensor, 20 m	31303050
Angle sensor 30° with AMP connector, without cable, with boom	30303672/ 3030367201
Angle sensor 60° with AMP connector, without cable, with boom	30303673/ 3030367301
Angle sensor 120° with AMP connector, without cable, with boom	30303675/ 3030367501
Connector cable for sensors, 2 m with 3-pin AMP socket to junction box	30303294
Connector cable for sensors, 4 m with 3-pin AMP socket to junction box	30303296
Connector cable for sensors, 6 m with 3-pin AMP socket to junction box	30303295
Connector cable for sensors, 8 m with 3-pin AMP socket to junction box	30303297

EDS Module

ECU EDS

Designation	Item number
EDS communication module	3030308530

EDS Equipment

Designation	Item number
EDS module, quadruple, 6 mm Luft Single, for single nozzle holder, cable length 2x 1.1 m	3030308303
EDS module, quadruple , 6 mm air Twin, for double nozzle holder, cable length 2x 0.6 m	3030308304
EDS module, quadruple , 6 mm air Quattro, for quadruple nozzle holder, cable length 2x 0.35 m	3030308305
Extension cable, 0.85 m , with 10-pin socket / 10-pin connector	3030308320
Extension cable, 1.35 m , with 10-pin socket / 10-pin connector	3030308321
Extension cable, 2.35 m , with 10-pin socket / 10-pin connector	3030308322
Quick exhaust valves for EDS module, 6 mm, 100-piece packaging unit	3030308335

Optional for Gyroscope

Designation	Item number
Gyroscope with 2x bracket, with AMP connector	30303685
VARIO-Select activation for automatic nozzle selection	30303080

Connector Cable for Sensors and Gyroscope

Designation	Item number
Connector cable for sensors, 2 m with 3-pin AMP socket to junction box	30303294
Connector cable for sensors, 4 m with 3-pin AMP socket to junction box	30303296
Connector cable for sensors, 6 m with 3-pin AMP socket to junction box	30303295
Connector cable for sensors, 8 m with 3-pin AMP socket to junction box	30303297

EDS Electric ECU

Designation	Item number
Communication module for HYPRO-EDS	3030308533
Communication module for LECHLER ESV	3030308532

