

NAVIGATOR TITANIUM DELTA FORCE 4000/5000/6000



Original

Operator's manual

67001104-100, version 1.00

GB - 04.2026



www.hardi.com.au

We congratulate you for choosing a HARDI plant protection product. The reliability and efficiency of this product depends upon your use and care.

The first step is to carefully read this Operator's manual, as it contains essential information. This will help you avoid dangers, reduce repair costs and downtimes, and increase the reliability and lifetime of your machine.

Sprayer Use

The HARDI sprayer is for the application of crop protection chemicals and liquid fertilizers, and it is designed only for that purpose.

If the sprayer is to be used for any other purposes than the ones described in this Operator's manual, a new risk assessment and a workplace assessment must be completed for this use. This obligation lies with the owner and operator of the sprayer.



Your HARDI sprayer is a machine [A] without drive system in accordance with directive 2006/42/EC, article 2.

It must be connected to a tractor [B], which is a driving machine subject to its own directive.

Together they make one machine [C] as defined in the directive 2006/42/EC, article 2.

Any person assigned to operate the machines (including connection to tractor, operation, preparation, maintenance and transportation) must read and apply the instructions, as the operator is sole responsible for safety and health when using the machines.

Before commissioning the sprayer, the owner and operator must therefore take note of the following obligations to avoid safety risks and unnecessary wear and tear:

- Workplace assessment
- Operator instructions
- Use of work equipment
- Statutory inspection
- Restricted use
- Maintenance regulations
- Health issues

For further details, please see the chapter "2 - General Safety and Responsibility" as well as the section "Intended use" in chapter "5 - Operations".

Operator's manual Formalities

The original Operator's manual is approved and published in English. All other languages are translations of the original manual. In the event of any conflicts, inaccuracies or deviations between the English manual and other languages, the English version shall prevail.

Illustrations, technical information and data in this manual are assumed to be correct at the time of printing.

As this Operator's manual covers more models and features or equipment, which are available in certain countries only, please pay attention to paragraphs dealing precisely with your model.

2 - General Safety and Responsibility

Reading this Instruction Book	9
Introduction	9
Obligations and Liability	10
Comply with the Operator's Manual	10
Before First Use of the Sprayer	10
Obligations of the Operator	11
Risks in Handling the Sprayer	12
Disclaimer	12
Organisational Measures	13
Personal Protective Equipment	13
Representation of Safety Symbols	14
Explanation of Symbols	14
Warning Signs On The Sprayer	15
Explanation of Labels	15
Safety and Protection Equipment	17
Safety at Start up	17
Faulty Safety Equipment	17
Informal Safety Measures	18
Additional Safety Instructions	18
Operator Training	19
Authorised Persons	19
Safety Measures Under Normal Operation	20
Protection Equipment	20
Residual Energy	21
Possible Dangers	21
Service and Maintenance Work	22
Preventive Measures	22
Design Changes	23
Operator Limitations	23
Spare Parts, Wear Parts and Aids	23
Cleaning and Disposal	24
Environmental Protection	24
Disposal of the Sprayer	24
Disposal of Cleaning Water	24
Workstation	25
Intended Place for Operator	25
Airborne Noise Emission	25
Risks of Non-Compliance	25
If the Safety Information is Ignored	26
Possible Risks and Dangers	26
Safety Information For Operators	27
General Safety and Accident Prevention	27
Coupling and Uncoupling the Sprayer	28
Use of The Sprayer	29
Road Transport	30
Hydraulic System	32
Electrical System	33
Universal Joint Shaft	34
Working Area of the Sprayer	35
Field Sprayer Operation	36
Environmental Precautions	36
Environmental Info	37
Service Work Precautions	37

Table of Contents

Cleaning	37
Service and Maintenance	38

3 - Technical Description

Important Info	39
Intended Use	39
Lifetime	40
Operating Limits	41
Liquid Fertilizer	42
Product Description	43
Front View	43
View	44
Platform	45
Right Side Cover	46
Dimensions and Specifications	47
General Info	47
Overall Dimensions and Specifications	47
Temperature and Pressure Ranges	48
Transmission Shaft	48
Hydraulic Couplings	48
CE Vehicle Rating Plates	49
Spray pump	50
Pump	50
Ace Centrifugal pump (Optional)	50
Pump Capacity	50
Liquid System	51
Tank Volume Sensor	51
TurboFiller	52
DynamicFluid4 Pressure Regulation	53
Valves and Symbols	54
Agitation Valve (Green symbols)	55
Filters	56
EasyCleanFilter (For 364 pump)	57
CycloneFilter	58
RinseTank	59
Clean water tank	59
ActivAir (Optional)	60
Air compressor	60
Air tank	60
Unloader valve	60
Air filter assembly	61
Spray Boom	62
General Info	62
Terminology	62
Standard Boom Features	62
Available Working Widths	63
Electrical Connections	64
Power Supply	64
Hydraulic System	65
Hydraulic Blocks	65
Hydraulic Motor for Liquid Pump (Optional)	67
Equipment	68
Operating the Grip (Optional)	68
SetBox Controls (Optional)	68
Drawbars	69
Nozzle Pressure Gauge	69
SafetyLocker	70

Filling Systems	71
Optional Filling systems and equipment	71
Filtered Fill	71
Hydraulic Filtered Fill (Optional)	72
 4 - Sprayer Setup	
General info	73
Before Putting the Sprayer into Operation	73
Jack Stand	73
Jack Up the Sprayer	74
ParaLift Lock Brackets	74
Tractor Requirements and Suitability	75
Tractor Selection	75
Tractor Requirements	76
Transmission Shaft	78
Operator Safety	78
PTO Installation	78
Mechanical Connections	79
Fixed Drawbars	79
Hose Rack	79
Hydraulic Systems	80
General Info	80
Requirements for Tractor	80
Adjusting Oil Flow for Hydraulic motor	81
Tractors with Dedicated Oil Flow Priority	82
Tractors with Flow Control for each Tractor Outlet	83
Tractors without Flow Control and Priority	83
Open and Closed Centre Hydraulics	84
Adjustment of Boom Folding Speed	85
Adjustment of Pendulum Damping	86
Electrical Connections	88
Road Safety Kit	88
Speed Sensor for Sprayer	89
Liquid System	90
Water Sensitive Paper	90
Track Width, Axles and Wheels	91
Turning the Wheel Rim	91
Altering the track width	91
Transport	92
Transport lock boom DDZ	92
Counter Weight	93
 5 - Operation	
Operating the Spray Boom	95
Safety Info	95
Manoeuvring of the Boom (Z-versions)	96
Applicable for SmartCom controllers	96
With Grip and SetBox (optional)	97
Single-side Half Boom Wing (Option for 2-fold booms)	98
Single-side 2/3 Boom Wing (Option for 3-fold booms)	98
Night Spraying Light (Optional)	99
Liquid System	100
General Info	100
Quick Reference - Operation	100

Table of Contents

Filling/Washing Location Requirements	101
Valves and Symbols	102
Manual Agitation Valve (Green symbols)	103
Filling of Tanks	104
Filling the CleanWaterTank	104
Filling of Water	104
Filling the RinseTank (Filtered - External pump)	105
Filtered Fill system (Filtered - External pump)	106
Hydraulic Filtered Fill System (with high capacity Banjo Pump) (Optional)	107
Filling of Chemicals	108
Safety Precautions - Crop Protection Chemicals	108
TurboFiller	109
Operating the TurboFiller	109
Filling Liquid Chemicals Using the TurboFiller	111
Filling Powder Chemicals Using the TurboFiller	112
TurboFiller Rinsing	114
Filling chemicals through chemical probe	115
In-field Operation	116
Operating the Control Units While Spraying	116
Agitation Before Resuming a Spray Job	117
Before Returning to Refill the Sprayer	117
Parking the Sprayer	117
Cleaning	118
General Info	118
Quick Reference - Cleaning	119
Standard Cleaning using On-screen Functions	120
General Cleaning of MainTank and Liquid System	121
Cleaning and Maintenance of Filters	122
Use of RinseTank and Rinsing Nozzles	123
Rinsing When MainTank Is Not Empty	124
Use of Cleaning Agents	124
Using the Drain Valve	125
BoomFlush - Manual Cleaning	126
Full Internal Cleaning (Soak Wash)	127
Technical Residue	128

6 - Maintenance

Lubrication	131
General Info	131
Recommended Lubricants	131
Grease Nipple	132
Grease Gun Calibration	132
Lubrication Plan - Boom Centre	132
Lubrication and Oiling Plan - Boom Wings	133
Lubrication Plan - Pump Greasing	133
Brakes	134
General Info	134
Brakes	134
Scheduled Maintenance	135
General Info	135
Warranty	135
Service Intervals	135
Daily Service - Air tank	136
10 Hours Service - Nozzle Filters (If fitted)	136
10 Hours Service - Spraying Circuit	136
10 Hours Service - Brakes	136

Table of Contents

10 Hours Service - EasyCleanFilter	137
10 Hours Service - CycloneFilter	138
10 Hours Service - In-Line Filter	139
10 Hours Service - Suction Filter for Ace pump (Optional)	140
10 Hours Service - Air compressor	141
10 Hours Service - Pre cleaner	141
10 Hours Service - Ace Pump	142
10 Hours Service - Ace pump	142
10 Hours Service - Spraying Circuit	142
10 Hours Service - Brakes	142
50 Hours First Service ONLY - Hydraulic Filter	143
50 Hours First Service ONLY - PWM Filter (for ACE pump)	143
50 Hours Service - Air compressor	143
50 Hours First Service ONLY - Air compressor	143
50 Hours Service - Ace pump	144
50 Hours Service - Greasing the Pump	145
50 Hours Service - Transmission Shaft (PTO)	146
50 Hours Service - Wheel Nuts	147
50 Hours Service - Tyre Pressure	147
100 Hours Service - Air Filter/Lubricator	148
100 Hours Service - Re-tightening the Spray Boom	149
100 Hours Service - Hydraulic Motor for Pump	150
250 Hours Service - Hydraulic Circuit	151
250 Hours Service - Hoses and Tubes	151
250 Hours Service - Adjustment of Wheel Brakes	152
250 Hours Service - Wheel Bearings	153
250 Hours Service - Parking Brake	153
250 Hours Service - Hydraulic Brakes	153
250 Hours Service - Air compressor	154
250 Hours Service - Hydraulic Filter	154
250 Hours Service - PWM Filter (for ACE pump)	154
250 Hours Service - Retightening the Chassis	155
500 Hours Service - Replacing the Filter Element in the Air Filter/Lubricator	156
1000 Hours Service - Wheel Bearings and Brakes	157
1000 Hours Service - Ace pump	159
1000 Hours Service - Air compressor	159
Occasional Maintenance	160
General Info	160
Lifting and Removing the Pump	160
Speed Transducer for the Pump	161
Pump Valves and Diaphragms Renewal	162
Symbols for Valves	164
Safety Valve Activation	164
Cone Check/Renewal for the Pressure Regulation Valve	165
Drain Valve Seal Replacement	165
3-Way Valve Adjustment	166
Feed Pipe Clamp Assembly	167
Feed Pipe Snap-Lock Assembly	167
Nozzle Holder Assembly	168
Nozzle Pipe Assembly	170
Wear Bushing Replacement on ParaLift	171
Suspension Rubber Dampers	172
Replacement of the Transmission Shaft Shield	172
Replacement of Transmission Shaft Cross Journals	172
Light Bulb Change	172
Tyre Change	173
Venting the Boom Hydraulics	174
Venting the Steering Hydraulics	175
Readjustment of Boom	176

Table of Contents

General Info	176
Boom Adjustment Order	176
Adjustment of Boom Tilt	177
Horizontal Alignment of Inner Sections	178
Horizontal Alignment of Breakaway Section	179
Vertical Alignment of Outer Sections 1 and 2	180
Adjustment of Boom Lock	181
Vertical Alignment of Breakaway Section	181
Adjustment of Folding Cylinder	182
Spring Load for Breakaway Section	183
Yaw Damping	183
Alignment of Rubber Pads on Spray Boom	185
Adjustment Procedure for MK IV LGM Load Genies	186
Off-Season Storage	187
General Info	187
Before Storage	187
After Storage	188
7 - Fault Finding	
Operational Problems	189
General Info	189
Liquid System	190
Pump	191
Hydraulic System, Z-version	192
Overview of Fuses	193
Mechanical Problems	196
Emergency Operation - Liquid System	196
Emergency Operation - Hydraulics	196
Emergency Operation - EasyCleanFilter	196
8 - Diagrams	
Hydraulic Diagrams	197
Hydraulics for Boom of 24 Meters (Z-version)	197
Hydraulics for Boom of 24-30 Meters (Z-version)	198
Hydraulics for Boom of 27-30 Meters (Z-version)	199
Hydraulics for Boom of 36 Meters (Z-version)	200
Hydraulics for Boom of 36 Meters (Z-version)	201
Liquid System	202
Diagram - Basic Liquid System	202
Other Specifications	203
Tightening Bolts and Nuts	203
Tightening Hydraulic Hoses	204
Tyre Pressure	205
Electrical Connections	206
Rear Lights	206
Boom and Work Light	206

Index

Reading this Instruction Book

Introduction

Before commissioning the machine, read and strictly comply with this instruction book. In doing so, you will avoid accidents, reduce repair costs and downtime and increase the reliability and service life of your machine. Especially pay attention to safety notes!

HARDI will not assume liability for any damage or malfunctions resulting from failure of complying with the operating instructions. These operating instructions will assist you in getting to know your machine and using it correctly for its intended purposes.

The instruction book must be read and strictly adhered to by any person commissioned to performing tasks on or with the machine, including:

- Daily operation (including preparation, fault rectification during work, care work)
- Maintenance or inspection work
- Transportation

Trained personnel of our service and sales partners will instruct you in the operation and care of your machine. By submitting the warranty documentation, you have confirmed proper acceptance of the machine.

For Operators Who Do Not Typically Read Instruction Manuals

1. You have purchased a field sprayer that requires proper understanding of its operation and maintenance. Many components demand practice and careful handling—always begin cautiously.
2. Improper use of the sprayer can be hazardous. In the best case, misuse may result only in damage to the equipment.
3. Please read this instruction manual before contacting your local HARDI dealer.
4. Aggressive driving or operating the machine irresponsibly in rough terrain—whether in the field or during transport—will adversely affect its performance and longevity.
5. Operators who are not attentive risk causing harm to themselves and to others nearby.
6. Lack of attention may also lead to incorrectly attributing operational failures to the machine rather than to improper handling.
7. Damage resulting from incorrect use or insufficient maintenance may lead to denial of warranty claims.

For Operators Who Always Read Instruction Manuals

1. It is good that you read the instruction book. Thereby you can be sure to get the best possible start with your new sprayer!
2. You are a concerned person who realises that even the sprayer is good to buy, it will not just work by itself.
3. You ensure a good success when making yourself familiar with every part of the machine and to get acquainted with its handling.
4. You will be satisfied both with the machine as also with yourself, which is the purpose of this instruction book.
5. If in doubt about anything in this instruction book, contact the local HARDI dealer for further advice.
6. If accident occurs, do not despair - the sprayer can be repaired.

2 - General Safety and Responsibility

Obligations and Liability

Comply with the Operator's Manual

Knowledge of the basic safety information and safety regulations is a fundamental requirement for safe handling and fault-free sprayer operation.

Lack of knowledge or non-compliance of the safety regulations can lead to injuries and fatal accidents as well as damage to the sprayer and its surroundings.

Follow the safety instructions in this operator's manual.



Before First Use of the Sprayer

The owner of the sprayer must take note of the following obligations before using the sprayer. These obligations also apply to the employer or the supervisor of the sprayer operators.

Workplace Assessment

This must be completed to start with. Check your local regulations regarding:

- The content of the workplace assessment.
- The frequency of repeating the workplace assessment.

Worker / Operator Instructions

Only let those people work with, or on the sprayer, who:

- Are aware of the basic workplace safety information and accident prevention regulations.
- Have been instructed in working with/on the tractor and sprayer and hereby achieving appropriate qualifications.
- Have read and understood this Operator's Manual.

If you still have queries after reading the Operator's Manual, or if something remains unclear after reading it, please contact the manufacturer or your HARDI dealer.

A worker is hereinafter called an operator. An operator is a person who installs, operates, configures, adjusts, maintains, cleans, repairs, transports or moves the sprayer.

Use of Work Equipment

Throughout the lifetime of the sprayer, the owner shall take every measure to ensure the safety of the sprayer and its equipment made available to operators.

In this directive, the "minimum safety and health requirements for the use of work equipment by workers at work" are described in full. To guide you in this matter, the issues concerning your work with the sprayer are listed below. However, HARDI do not accept liability that the issues listed cover the requirements in the directive fully. This responsibility lies with the owner of the sprayer to ensure the safety of the operator in accordance with all of the relevant act (s).

Restricted Use

As the use of the sprayer is likely to involve a specific risk, the owner shall ensure restricted access to its use as needed, and any modification of the restrictions is to be allowed to specialized persons only.

Maintenance Regulations

Throughout its working life, the owner shall keep the sprayer compatible with the current safety regulations by means of adequate maintenance.

The owner shall ensure that the sprayer is installed and set up correctly and is operating properly by inspection/testing of the sprayer (initial, after assembly, periodic and special) by authorized persons. The results of inspection/testing shall be recorded and kept.

Health Issues

Ergonomics and occupational health aspects shall be taken fully into account by the owner.

2 - General Safety and Responsibility

Obligations of the Operator

Before starting work, the operator or anyone in charge of working with/on the sprayer is obliged to:

- Comply with the basic workplace safety acts and accident prevention regulations.
- Read and follow the safety instructions as described in this Operator's Manual.
- Read the section "Representation of Safety Symbols" in this Operator's Manual and to follow the safety instructions represented by the danger, warning and attention symbols, when operating the sprayer.
- Get to know the sprayer.
- Connect the sprayer securely and correctly to a tractor, which has passed the test for driving the sprayer.
- Read the sections of this Operator's Manual that are important for carrying out the work.
- Read the manufacturer's information regarding safety and use of chemical products for crop care, such as spray chemicals or liquid fertilizer.
- Keep all the danger, warning and attention labels on the sprayer in a legible state.
- Replace damaged labels on the sprayer.
- Know the importance of the use of genuine HARDI spare parts.

If the operator discovers that a function is not working properly, he must eliminate this fault immediately. If this is not the task of the operator, or if the operator does not possess the appropriate technical knowledge, then he should report this fault to his superior (a qualified operator).

2 - General Safety and Responsibility

Risks in Handling the Sprayer

Operating the sprayer may cause risks and restrictions to:

- The health and safety of the operator or third parties.
- The sprayer.
- Other property.

Only use the sprayer:

- For the purpose for which it was intended.
- In a perfect state of repair.

Eliminate any faults immediately which could impair the safety.

Disclaimer

Our "General Terms of Sale and Delivery" are always applicable. These shall be available to the owner at the latest on conclusion of the contract.

Warranty and liability claims for damage to people or property will be excluded by HARDI, if they can be traced back to one or more of the following causes:

- Improper use of the sprayer.
- Improper installation, commissioning, operation and maintenance of the sprayer.
- Operation of the sprayer with defective safety equipment, or improperly attached or non-functioning safety equipment.
- Non-compliance with the instructions in the instruction manual regarding commissioning, operation and maintenance.
- Unauthorized design changes to the sprayer.
- Insufficient monitoring of sprayer parts which are subject to wear.
- Improperly executed repairs.
- Spare parts used are not genuine HARDI spare parts. If the operator decides to use a spare part, which is not approved by HARDI, the operator immediately assumes responsibility for any accident, damage or malfunction, which can be traced back to the use of this spare part. HARDI accepts no liability for such incidents caused by the use of non-approved spare parts, wear parts or aids.
- Disasters through the impact of foreign bodies, natural disasters or force majeure.

2 - General Safety and Responsibility

Organisational Measures

This Operator's Manual

- Must always be kept together with the sprayer.
- Must always be easily accessible for the operator.

Personal Protective Equipment

The operator must use the necessary personal protective equipment as per the information provided by the manufacturer of the plant protection product to be used, such as:



Chemical-resistant gloves



Chemical-resistant and disposable overalls



Water-resistant footwear



Face shield



Breathing protection



Eye protection



Head protection



Skin protection products

2 - General Safety and Responsibility

Representation of Safety Symbols

Explanation of Symbols

Safety symbols are used in the following chapters throughout this Instruction Book to designate, where the reader has to pay extra attention.

The signal word (DANGER, WARNING, ATTENTION or NOTE) describes the severity of the risk.

The symbols have the following meaning:



This symbol means DANGER. Be very alert as your safety is involved! The DANGER symbol indicates a high risk for an immediate death or serious physical injury, if the instruction is not followed.



This symbol means WARNING. Be alert as your safety can be involved! The WARNING symbol indicates a medium risk for immediate death or serious injury, if the instruction is not followed.



This symbol means ATTENTION. This indicates an obligation to special behaviour or an activity required for proper sprayer handling. This instruction will help you to avoid faults on the sprayer or disturbance to the environment.



This symbol means NOTE. This indicates handling tips and particularly useful information. This instruction will help you to use all the functions of your sprayer in the best way possible for a better, easier and more safe operation.

Warning Signs On The Sprayer

Explanation of Labels

The labels on the sprayer are designating potential dangerous places on the machine. Anybody working with or being in close range of the sprayer must respect these warnings!

Therefore, the labels should always be clean and readable! You must replace worn or damaged labels with new ones. Contact your local dealer for new labels.

Not all labels shown hereafter will apply to your sprayer - this depends on the sprayer model and variant.

Explanation of labels:



978437 Chemical handling!

Carefully read the informations about chemical preparation before handling the machine. Observe instructions and safety rules when operating.



978443 Service!

Carefully read the Operator's Manual before handling the machine. Observe instructions and safety rules when operating.



978436 Service!

Turn off the engine and remove ignition key before performing maintenance or repair.



978440 Service!

Tighten to the torque according to Operator's Manual.



97802100 Risk of death!

Do not attempt to enter tank.



978447 Risk of burn!

Stay clear of hot surfaces.



978444 Risk of injury!

Do not open or remove safety shields while engine is running.



978586 Risk of injury!

Flying objects - keep safe distance from the machine, as long as the engine is running.



978448 Risk of injury!

Keep sufficient distance away from electrical power lines.



978435 Risk of injury!

Keep hands away.

2 - General Safety and Responsibility



978441 Risk of squeezing!
Stay clear of raised unsecured loads.



978445 Risk of squeezing!
Never reach into the crushing danger area as long as parts are moving.



978434 Risk of squeezing!
Keep hands away, when parts are moving.



978442 Risk of falling off!
Do not ride on platform or ladder.



978446 Risk of sprayer tipping over!
Be aware when disconnecting the sprayer.



978438 Grip area!
Manual handling of the boom, etc.



97802200 Not for drinking!
This water must never be used for drinking.



97802300 Not for drinking!
This water must never be used for drinking.



97829000 Lifting point!



978439 Lifting point!



Cyclone filter service!
Open and clean filter monthly.

97827000

2 - General Safety and Responsibility

Safety and Protection Equipment

Safety at Start up

Each time before the sprayer is started up, all the safety and protection equipment must be properly attached and fully functional. Check all safety and protection equipment regularly. Repair or replace the equipment as needed.

Faulty Safety Equipment

Faulty or disassembled safety and protection equipment can lead to dangerous situations.

2 - General Safety and Responsibility

Informal Safety Measures

Additional Safety Instructions

Together with the safety information in this Operator's Manual, also comply with the general and national regulations related to:

- Accident prevention.
- Environmental protection.
- The applicable workplace safety.

Follow these regulations, especially when:

- Driving on public roads and routes. Comply with the appropriate statutory road traffic regulations. There may be local regulations which need to be followed.
- Local law may demands that the operator is certified to use spray equipment.
- Make sure you understand the information from the supplier regarding pesticides or liquid fertilizer use.

2 - General Safety and Responsibility

Operator Training

Authorised Persons

Only those people who have been trained and instructed may work with/on the sprayer. The operator must clearly specify the responsibilities of the people in charge of operation and maintenance work.

People being trained may only work with/on the sprayer under the supervision of an experienced operator.

	Person especially trained for the activity ¹⁾	Trained operator ²⁾	Person with specialist training (specialized workshop) ³⁾
Loading / Transport	X	X	X
Commissioning	0	X	0
Setup and tool installation	0	0	X
Operation	0	X	0
Maintenance	X	X	X
Troubleshooting and fault elimination	X	0	X
Disposal	X	0	0

Symbols: X - permitted, 0 - not permitted.

1. Persons who can assume a specific task, and who can carry out this task for an appropriately qualified company. Examples of these persons are truck drivers, machinery dealer, etc.
2. Persons who have been instructed in their assigned tasks and in the possible risks in the case of improper behaviour, who have been trained if necessary, and who have been informed about the necessary protective equipment and measures. Examples of these persons are customers, farmers and farm workers.
3. Persons with specialist technical training shall be considered as a specialist. Due to their specialist training and their knowledge of the appropriate regulations, they can evaluate the work with which they have been appointed to and detect possible dangers. Examples of these persons are sprayer importers, dealers and service engineers and service technicians.

Comment:

A qualification equivalent to specialist training can be obtained from several years of experience in the relevant field.

If maintenance and repair work on the sprayer is additionally marked "Workshop work", or a similar marking, only a specialized workshop may carry out such work. The personnel of a specialized workshop shall possess the appropriate knowledge and suitable aids (tools, lifting and support equipment) for carrying out the maintenance and repair work on the sprayer in a way that is both appropriate and safe.

2 - General Safety and Responsibility

Safety Measures Under Normal Operation

Protection Equipment

Only operate the sprayer if all the safety and protection equipment is fully functional.

Check the sprayer at least once a day for visible damage and check the function of the safety and protection equipment.

Residual Energy

Possible Dangers

Note that there may be residual energy from mechanical, hydraulic, pneumatic and electric / electronic parts on the sprayer.

Use appropriate measures to inform the operators.

Prevent any accidents from happening due to residual energy.

Below are some examples on where the sprayer's residual energies may be present:

Mechanical Energy

- Springs under tension.
- Weights exposed to gravity.
- Heat from brake drums.
- Heat from wheel motors.

Hydraulic Energy

- Trapped oil under pressure in cylinders, hoses and accumulators.
- Heat from cylinders and oil tank.

Pneumatic Energy

- Air tank.
- Air activated brake system.
- Pressure dampers for fluid system.

Electric Energy

- Energy stored in capacitors.
- Tractor battery. 12v DC battery.

2 - General Safety and Responsibility

Service and Maintenance Work

Preventive Measures

Before carrying out service and maintenance work, secure against unintentional start-up. This goes for:

Hydraulic system

- Set the tractor's hydraulic levers in neutral position to relieve oil pressure.
- Turn off the tractor ignition and remove the ignition key. Disconnect the hydraulic hoses connected from the tractor to the sprayer.

Electric system

- Turn off the tractor ignition and remove the ignition key.
- Disconnect the electric cables from the tractor's battery. Turn off the isolation switch.

Fluid system

- Turn off the tractor ignition and remove the ignition key.

Compressed air

- Turn off the tractor and remove the ignition key. Drain the air tank.

Carry out prescribed service, maintenance and inspection work in due time. This will help to eliminate faults on the sprayer, including safety related functions.

Check all the screw and bolt connections for firm seating. On completion of the maintenance work, check the function of the safety devices.

2 - General Safety and Responsibility

Design Changes

Operator Limitations

You may make no changes, expansions or modifications to the sprayer without an authorization from HARDI. This also applies when welding support parts.

Any expansion or modification work shall require the written approval from HARDI. Only use modification and accessory parts approved by HARDI, so that the type approval or other design approvals remain valid in accordance with national and international regulations.

Vehicles with an official type approval, or with equipment connected to a vehicle with a valid type approval, or approval for road transport according to the local road traffic regulations, must be in the state specified by the approval.

It is strictly forbidden to:

- Drill holes in the steel frame or in the running gear.
- Increase the size of existing holes in the steel frame or in the running gear.
- Weld support parts.

Risk of crushing, cutting, catching, squeezing, getting trapped, being drawn in or being struck by sprayer parts due to the failure of support parts.

Spare Parts, Wear Parts and Aids

Immediately replace any sprayer parts which are not in a perfect state.

Only use genuine HARDI spare and wear parts or those approved by HARDI, so that the type approval remains valid according to the national and international regulations. The use of spare and wear parts from third parties does not guarantee that they have been constructed in a way as to meet the requirements placed on them.

HARDI accept no liability for damage caused by the use of non-approved spare parts, wear parts or aids.

2 - General Safety and Responsibility

Cleaning and Disposal

Environmental Protection

Carefully handle and dispose of any materials used, in particular:

- When carrying out work on oiled or lubricated sprayer parts.
- When cleaning using solvents.

Always follow local legislation regarding disposal.

Disposal of the Sprayer

You must thoroughly clean the equipment when it has completed its working life.

Incinerate the tanks, hoses and synthetic fittings at an authorized disposal plant.

It is possible to scrap the metallic parts. Steel parts are made of various types of treated steel.

Always follow local legislation regarding disposal.

Materials Used

Parts	Materials
Tanks:	Plastic (HDPE)
Chassis:	Steel
Boom:	Steel
Tyres:	Rubber
Mudguards:	Plastic (PE)
Pump housing:	Grey cast iron (GG200)
Pump diaphragms:	Plastic (PUR)
Hoses (suction lines):	Plastic (PVC)
Hoses (pressure lines):	Rubber (EPDM)
Valves:	Glass reinforced plastic (PA)
Hose and pipe fittings:	Glass reinforced plastic (PA)
Filter housings:	Plastic (PP)
Nozzles:	Plastic (POM)

Disposal of Cleaning Water

Protect the environment.

When cleaning the sprayer inside and outside, dispose of chemical residues in the liquid system and water containing cleaning agent according to local regulations.

Workstation

Intended Place for Operator

There may be only one person sitting in the driver's seat of the tractor connected to the sprayer. This is the intended workstation for operating the sprayer.

Airborne Noise Emission

Airborne noise emission from operating the sprayer relates to the two defined operator positions, which is in the tractor cab or when operating the TurboFiller (chemical filling device). Reference measurements indicate only in the latter case (operating the chemical filling device) a contribution from the sprayer of additionally 4 dB(A).

Risks of Non-Compliance

During the operation or transport of the sprayer:

If another person disturbs or interferes with the operator, or if the operator is trying to operate the sprayer from other places than the tractor's driver seat, this can result in negligent or incorrect handling of the vehicle.

- Risk of the operator losing his concentration and focus on operating the vehicle correctly.
- Risk of the operator losing his ability to operate the vehicle correctly.
- Risk of fatal accidents while driving.
- Risk of damages to the tractor, sprayer and foreign objects while driving.
- Risk of inefficient spraying due to incorrect operation of the sprayer.

2 - General Safety and Responsibility

If the Safety Information is Ignored

Possible Risks and Dangers

Non-compliance with the safety information:

- Can pose a danger to people, to the environment and to the sprayer.
- Danger to people through non-secured working areas.
- Danger to people through mechanical and chemical influences.
- Failure of important sprayer functions.
- Failure of prescribed methods of maintenance and repair.
- Leakage of hydraulic oil or spray fluid to the environment.
- Can lead to the loss of all warranty claims.

Safety Information For Operators

General Safety and Accident Prevention

Before use or starting up the sprayer and the tractor, always check their:

- Roadworthiness
- Operational safety

Risk of crushing, cutting, catching, squeezing, getting trapped, being drawn in or being struck by sprayer parts due to inadequate roadworthiness and operational safety.

Beside these instructions, comply with the generally applicable national safety and accident prevention regulations.

The warning symbols and other labels attached to the sprayer provide important information on safe sprayer operation. Compliance with this information is in the interests of your safety.

Keep the spray boom in folded position, whenever the sprayer is not coupled to a tractor. Unfolding the boom on an uncoupled sprayer will shift the balance point of the sprayer causing a risk of overturning.

Before driving off and starting up the sprayer, check the immediate area of the sprayer - look out especially for children and instruct them and other unauthorized persons to stay out of reach of the sprayer. Ensure that you can see clearly.

Drive in such a way that you always have full control over the tractor with the attached sprayer. In doing so, take your personal abilities into account, as well as the road, traffic, visibility, weather conditions and the driving characteristics of the tractor and of the connected sprayer.

Slow down when driving in uneven terrain or when making sharp turns, as the sprayer might be at risk of turning over.

It is forbidden to ride on the sprayer or use it as a means of transport.

It is forbidden to stay in the working area of the sprayer's drawbar, on the sprayer's platform or behind the operating area (the tractor), unless the hydraulic pressure to the sprayer has been switched off.

Only authorised persons are allowed inside or outside the tractor cabin during operation.

Keep persons, children and animals away from the operation areas of the sprayer and from the sprayer's equipment. Be careful when manoeuvring the sprayer, especially when reversing, as there is a risk of hitting people or surroundings.

Avoid eating, drinking or smoking while spraying or working with equipment contaminated with chemicals.

The chemicals used for spraying are dangerous to your health! In case of ingestion, poisoning or damage to your skin or face, immediately seek medical advice. Remember to identify the chemicals used.

2 - General Safety and Responsibility

Coupling and Uncoupling the Sprayer

Only connect and transport the sprayer with tractors suitable for the task. See the section “Technical Specifications” in this manual to make sure that the tractor matches the requirements to operate the sprayer.

When coupling sprayers to the tractor's three-point linkage, the linkages of the tractor and the sprayer must always be the same.

Connect the sprayer to the prescribed equipment in accordance with the specifications.

When coupling sprayers to the front or the rear of the tractor, the following may not be exceeded:

- The approved total tractor weight.
- The approved tractor axle loads.
- The approved load capacities of the tractor tyres.
- The approved load capacities of the tractor hitch points.

Secure the tractor and the sprayer against rolling unintentionally before coupling or uncoupling the sprayer.

It is forbidden for people to stand between the sprayer to be coupled and the tractor, while the tractor is moving towards the sprayer.

Any helpers may only act as guides standing next to the vehicles, and helpers may only move between the vehicles when both are at a standstill.

If using the tractor's three-point linkage, including lift arms (lower links), secure the operating lever of the tractor's hydraulic system, so that unintentional raising or lowering is prevented when coupling or uncoupling the sprayer.

When coupling and uncoupling sprayers, move the support equipment, such as jack stand, to the appropriate position (check stability and strength of the ground).

Be particularly careful when coupling the sprayer to the tractor or uncoupling it from the tractor. There are crushing and cutting points in the area of the coupling point between the tractor and the sprayer.

It is forbidden to stand between the tractor and the sprayer when raising or lowering the three-point linkage.

Coupled supply lines

- Must yield to all movements while cornering without tensioning, kinking or rubbing.
- Must not rub against other parts.

Also ensure that uncoupled sprayers are in a stable position.

2 - General Safety and Responsibility

Use of The Sprayer

Before starting work, ensure that you understand all the equipment and actuation elements of the sprayer and their function. There is no time for this when the sprayer is already in operation.

Do not wear loose clothing. Loose clothing increases the risk of being caught by the drive shaft / PTO.

Only start the sprayer, when all the safety equipment has been attached and in the safety position.

Comply with the maximum load for the connected sprayer and the permissible axle and drawbar loads for the tractor. If necessary, drive only with a partially filled tank.

It is forbidden to:

- Stand in or near the working area of the sprayer.
- Climb the sprayer.
- Stand or sit on the sprayer.
- Stand in the turning and swivel range of the sprayer.

There are crushing and cutting points at externally actuated sprayer points, e.g. hydraulic cylinders.

Only actuate externally actuated sprayer parts when you are sure that no one is standing within the prescribed safety distance.

Before leaving the tractor cabin:

- Lower the spray boom to around waist height above the ground or lower.
- Fold the spray boom into the transport position.
- Activate the tractor's parking brake, put the transmission into (P).
- Turn off the tractor engine.
- Remove the ignition key.

Always keep the sprayer under supervision when:

- The vehicle is parked with the tractor engine running.
- The sprayer pump is running.
- The tank on the sprayer is being filled.

2 - General Safety and Responsibility

Road Transport

When driving on public roads or highways with the sprayer coupled to the tractor, the following instructions must be followed. Failure to do so will create a risk of:

- Traffic accidents or fatalities!
- Damage to the tractor and sprayer.

General Instructions

Comply with the national or local road traffic regulations when using public roads and highways.

When driving in areas with special rules and regulations for markings and lights on sprayers, you should observe these and equip your sprayer accordingly.

Make sure that you have a clear field of vision when driving.

Check the immediate vicinity of the vehicle; no persons, children or animals must be near the vehicle!

No one is allowed outside the tractor cabin during road transport.

It is forbidden to use the sprayer as a means of transportation of people or goods.

The tractor driver must not be disturbed by other people in the cabin during driving.

Adjust your driving speed to the prevailing conditions.

Before driving downhill, switch to a low gear.

When making turns, lower your speed.

Checking the Vehicle

Before transporting the sprayer on a road, complete the following check points for the tractor and sprayer.

- Spray boom is folded and resting in transport brackets with the intended locks engaged.
- Engage transport locks on the steering cylinders.
- Supply lines for hydraulic, electric and pneumatic systems (if installed) are correctly connected.
- Parking brake is completely disengaged. Safety line is secured (if applicable).
- Hydraulic pressure from tractor to sprayer is turned off.
- PTO drive is turned off, if the main tank is empty. If the main tank is filled with spray liquid, the need for agitation demands that the PTO drive is turned on.
- Hitch bolt(s) between tractor and sprayer must be secured with a linchpin or other appropriate means.
- If the sprayer is coupled onto a lift link drawbar, the lower link should be laterally fixed.
- Traffic lights and reflectors are in good working order, clean and free from damage.
- Signs or markings on the vehicle regarding road transport are correctly placed and visible.
- Brakes are in good working order and free from visible damage.
- Tyre pressure is correct according to the load.
- No cables or other parts must be strained or caught in the tractors wheels when cornering.
- Crop residues and dirt are removed.
- All moveable or loose equipment are securely latched or stowed away in the designated compartments.

2 - General Safety and Responsibility

Three-Point Linkage

If the sprayer is fixed to the tractor's three-point linkage or lower links, ensure sufficient side locking of the tractor lower links before driving off.

Before driving off, secure the operating lever of the three-point hydraulic system against the unintentional raising or lowering of the connected sprayer.

Carry out a visual check that the upper and lower link pins are firmly fixed with linchpins against unintentional release.

Braking and Steering

Braking distance is increased and steering capabilities are influenced, both when the sprayer's tank is empty and even more so with a full tank.

Ensure that the tractor has sufficient steering and braking power. If necessary, use front weights to bring the tractor into a well-balanced and stable position.

Any sprayers and front/rear weights connected to the tractor influence the driving behaviour and the steering and braking power of the tractor.

The front tractor axle must always be loaded with at least 20% of the tractor's empty weight, in order to ensure sufficient steering power.

Always fix the front or rear weights to the intended fixing points according to regulations.

Comply with the maximum load for the connected sprayer and the approved axle and drawbar loads for the tractor.

The tractor must guarantee the prescribed braking distance for the loaded vehicle combination (tractor plus connected sprayer).

Before driving off, always switch off independent wheel braking on the tractor (e.g. lock the braking pedals together).

When turning corners with the sprayer connected, take the broad load and balance weight of the sprayer into account. Slow down as needed to avoid tilting or overturning of the vehicle, especially on sloping roads.

2 - General Safety and Responsibility

Hydraulic System

The sprayer is supplied with hydraulic functions operating under a high pressure.

In case of malfunction, there is a risk that the hydraulic system may act inadvertently. This can lead to:

- Fatalities or serious injuries to persons or animals in the working area of the sprayer.
- Material damage to the sprayer when colliding with trees, vehicles or other objects in the working area of the sprayer.

Ensure that the hydraulic hose lines are connected correctly.

When connecting the hydraulic hose lines, ensure that the hydraulic system is depressurized on both the sprayer and tractor sides.

The operator-controls in the tractor, used for hydraulic and electrical movements of components must stay unlocked, e.g. for folding, swivelling and pushing movements. The movement must stop automatically when you release the appropriate control. This does not apply to equipment movements that:

- Are continuous.
- Are automatically controlled.
- Require a floating position or pressed position to function.

Before working on the hydraulic system:

- Lower the spray boom to its lowest position or into the transport position.
- Turn off / depressurize the hydraulic system.
- Turn off the tractor engine.
- Engage the parking brake.
- Remove the ignition key.

Have the hydraulic hose lines checked at least once during a calendar year by an expert to ensure that they are in safe working order.

Replace the hydraulic hose lines if they are damaged or worn, which is when:

- It is leaking.
- Reinforcement material inside the hose is visible due to cracks in the outer layers.

Only use genuine HARDI hydraulic hose lines.

The hydraulic hoses should not be in use for longer than 5 calendar years, including any storage time of maximum 2 years. Even with proper storage and approved use, hoses and hose connections are subject to natural ageing, thus limiting storage time and the time of use. However, it may be possible to specify the length of use from experience values, in particular when taking the risk potential into account. In the case of hoses and hose connections made from thermoplastics, other guide values may be decisive.

Never attempt to plug leaks in hydraulic hose lines using your hand or fingers. Escaping high pressure fluid (hydraulic oil) may pass through the skin and ingress into the body. Risk of serious injury or death.

If you are injured by hydraulic oil, contact a doctor immediately.

When searching for leaks, use suitable aids to avoid the serious risk of infection and injury.

2 - General Safety and Responsibility

Electrical System

When working on the electrical system and the sprayer is attached to the tractor, always disconnect the tractor's battery.

When disconnecting the battery, disconnect the negative terminal first, followed by the positive terminal.

When connecting the battery, connect the positive terminal first, followed by the negative terminal.

Always place the appropriate cover over the positive battery terminal. If there is accidental earth contact, there is a risk of explosion.

If climbing onto the sprayer during service work, be aware of the low voltage danger from electric components.

Only use the prescribed fuses. If the fuses used are too highly rated, the electrical system will be destroyed. Risk of fire.

The sprayer may be equipped with electronic components whose functions are influenced by electromagnetic interference from other units. Such interference can pose risks to people, if the following safety information is not followed:

- If retrofitting electrical units and/or components on the sprayer with a connection to the on-board power supply, the user is responsible for checking whether the installation might cause faults on the vehicle electronics or other components.

2 - General Safety and Responsibility

Universal Joint Shaft

A rotating shaft can catch clothes, tools or aids, if touching or getting in contact with each other. Risk of severe damage and injury as the rotating shaft is driven by powerful torque from the tractor.

Use only the power take-off (PTO) shaft prescribed by HARDI, equipped with the proper safety devices.

Read and follow the delivered instruction manual from the manufacturer of the PTO shaft.

The protective pipe and PTO shaft guard must be undamaged, and the shield of the tractor and sprayer universal joint shaft must be attached and be in proper working condition.

Safety devices must be in good condition when you are working with the sprayer.

You may install or remove the PTO shaft only after you have done all of the following:

- Switched off the universal joint shaft drive.
- Switched off the tractor engine.
- Removed the ignition key.
- Applied the parking brake.

Always ensure that the PTO shaft is installed and secured correctly both at the tractor end and at the sprayer pump end.

When using wide-angle PTO shafts, always install the wide angle joint at the pivot point between the tractor and sprayer.

Secure the PTO shaft guard by attaching the chain(s) to prevent movement.

Observe the prescribed pipe overlaps in transport and operational positions. See the operating manual from the PTO shaft manufacturer.

When turning around corners, observe the permitted bending and displacement of the PTO shaft.

Before switching on the universal joint shaft, check that the selected universal joint shaft speed (rpm) of the tractor matches the permitted drive speed of the sprayer.

Stay below the maximum speed (rpm) suitable for the PTO shaft.

Instruct people to leave the danger area of the sprayer, before you switch on the universal joint shaft.

While work is being carried out on the universal joint shaft, there must be no one in the area of the universal joint shaft or PTO shaft, while it is rotating.

When the tractor engine is turned off, the universal joint shaft must also be switched off. This prevents an unintentional restart of the universal joint shaft immediately, when the tractor engine is turned on again.

Always switch off the universal joint shaft if it is not needed in action, or if excessive bending of the PTO shaft occurs.

You may work on the sprayer only after all moving sprayer parts have come to a complete stop.

Secure the tractor and sprayer against unintentional starting and unintentional rolling, before you perform any cleaning, service or maintenance work on universal joint shaft-driven sprayers or PTO shafts.

After disconnecting the PTO shaft, place it on the holder provided.

After removing the PTO shaft, attach the protective sleeve to the universal joint shaft stub.

If using a travel-dependent universal joint shaft, note that the PTO speed depends on the drive speed of the vehicle, and that the direction of rotation reverses, when you drive in reverse.



2 - General Safety and Responsibility

Working Area of the Sprayer

Before operating the sprayer, the operator must ensure that the area around the sprayer is free.

This working area is defined as the area within the dashed line:

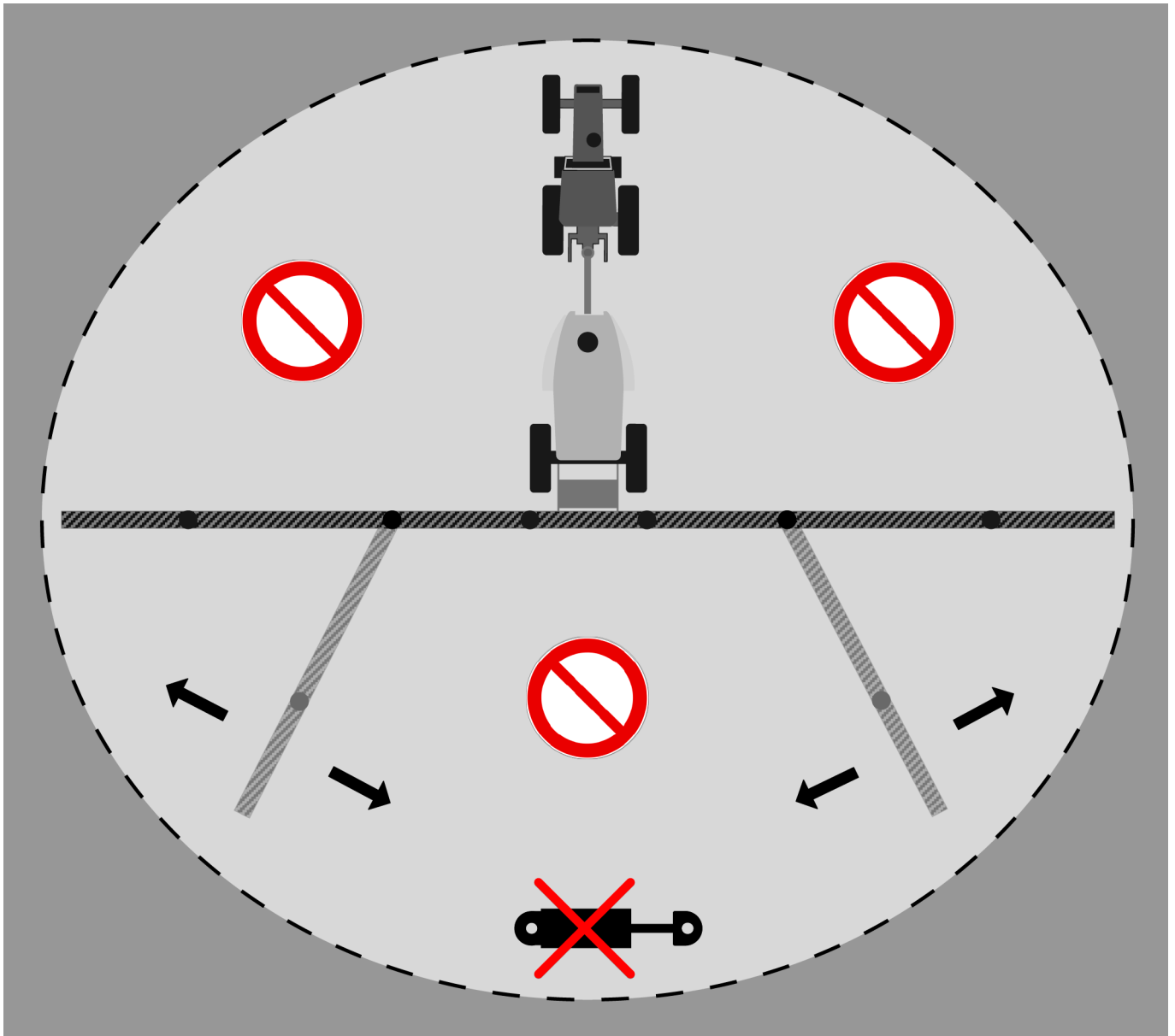

The working area includes the total width of the spray boom as well as the area used for boom folding. Please note the area immediately behind the sprayer, which is also defined as working area.

The size of the working area depends on the boom type and boom width. The operator must familiarize with the boom at hand before using the sprayer.



DANGER! Before the hydraulics for the sprayer are activated, there must be no risk of persons or other machines or vehicles entering the working area of the sprayer. Risk of damage and fatalities!

2 - General Safety and Responsibility

Field Sprayer Operation

Observe the recommendations from the manufacturer of the crop protection product in respect of:

- Personal protective equipment.
- Warning information on exposure to crop protection products.
- Regulations on dosing, applications and cleaning.

When there will be exposure to the crop protection product:

- Wear the proper personal protective equipment - this may differ depending on the chemical being sprayed.
- Wash and change clothes after spraying.
- Wash tools if they have been contaminated.

Observe the information in the national plant protection law.

Keep hoses, pipes or other lines closed, when they are under pressure.

When use of the TurboFiller has ended, make sure that all valves on the TurboFiller are closed / deactivated.

Only use genuine HARDI hoses and hose clamps for replacement, which stand up to chemical, mechanical and thermal requirements.

The rated volume of the spray liquid tank must not be exceeded during filling. If overfilled, some sprayer functions may be disabled. However, the MainTank is a little oversized to allow for foaming.

When using tractors with a cab with ventilation fans, replace the fresh air filters with activated carbon filters.

Observe the information on the compatibility of crop protections and substances for the field sprayer.

Be aware that some crop protection products have a tendency to stick together or settle when being mixed.

Do not fill the sprayer with water from bodies of water, which are open to the public. This is for the protection of people, animals and the environment due to the risk of contamination.

Only fill the sprayer using a free flow of water from the mains water supply or from an external water tank.

Environmental Precautions

It is essential to reduce the environmental impact of plant protection chemicals to a minimum. Particularly the soil, subsoil water, streams, lakes, flora and fauna must be in focus. Contamination of subsoil water must be prevented by paying particular attention to avoidance of spot contamination of the soil in connection with filling and washing and parking of the sprayer.

If any concentrated chemicals are spilled on the soil, the contaminated soil should be removed and sent for cleaning at a capable facility. Follow local regulations regarding disposal. This must be done to avoid seepage of chemicals to the subsoil waters. Avoid spillage - use the chemical filling device for filling the sprayer with chemicals.

Do not overfill the MainTank. The rated volume inside the MainTank is stated with large printed numbers on the outside of the tank. If overfilled, the spray liquid could leak from the sprayer causing contamination of the soil.

Before filling the sprayer with plant protection chemicals, the sprayer must be calibrated to apply the precise dose rate selected. The important input sensors are the flowmeter, the pressure sensor and the speed sensor.

It is recommended to establish a proper filling and washing area with a hard, impermeable surface that drains to a receptacle if the sprayer is always filled or cleaned in the same location on the farm. If a washing/filling location is NOT available, the following precautions should be taken:

- The sprayer should only be filled with clean water at the farm.
- The plant protection chemicals must be added and mixed in the field to be sprayed.
- Select a different location each time the sprayer is refilled.

2 - General Safety and Responsibility

Environmental Info

For environmental info, please refer to the following parts in the Spray Technique Book:

- Nozzles.
 - Spray quality.
 - Choosing nozzles for arable crops.
 - Spraying speed.
-

Service Work Precautions

Before carrying out any service work, all of the following instructions must be followed in order to prevent damages to the sprayer, injuries and fatalities:

- Do not walk under any part of the sprayer, unless it is secured. The spray boom is secured when placed in the transport brackets.
 - If the spray boom is folded up and resting in the transport brackets for service, check visually that the ParaLift locks are engaged (the boom is locked in place).
 - If the spray boom is unfolded for service, the boom must be lowered, until it reaches its end stop. Place strong trestles under the boom for support or use a lifting crane for support.
 - Never service or repair any equipment while it is operating.
 - Any service work should be carried out on level ground with authorised persons nearby.
 - Depressurise the hydraulic system for the sprayer to prevent unintentional movements of the sprayer.
 - Switch off the PTO.
 - Switch off the tractor ignition and remove the ignition key to prevent unintentional starting.
 - Activate the parking brake to prevent rolling.
 - Put wheel chocks in front and behind of the wheels to prevent the sprayer from rolling.
 - Electric power must be disconnected from the sprayer.
 - Any service work on electronic /electric parts must be carried out under dry conditions - no rain or splashes from water or other liquids.
-

Cleaning

When cleaning nozzles and filters, lower the spray boom to around waist height above the ground. For safety reasons, do NOT walk or stand below the boom or ParaLift during this cleaning work!

Dispose of oils, greases and filters in the appropriate way to protect the environment.

Cleaning of tanks:

- Due to toxic vapours from spray liquids in the MainTank, climbing into this tank is very hazardous. Cleaning should only be done from the outside.
- Do NOT enter the MainTank!
- Do NOT inspect any of the tanks with the liquid pump running!

Rinse and wash the equipment with clean water after use and before servicing.



WARNING! Do NOT use concentrated Chlorine for cleaning since Chlorine substances are corrosive and can damage electronic components.ince this can damage the electrical connections.



WARNING! Using a diluted solution is safer, but even then, it's best to avoid using chlorine on electronics due to the risk of corrosion from the chlorine gas it can release.

2 - General Safety and Responsibility

Service and Maintenance

Always reassemble all safety devices or shields immediately after servicing.

After a longer period of storage, the sprayer must be inspected by a qualified operator. Contact your HARDI dealer for more information.

Repair work in the MainTank must only be carried out by a specialised workshop.

Do NOT enter the MainTank!

Access to the RinseTank must only take place with the spray boom in transport position, and after it is verified that the transport locks are engaged.

Regularly check the nuts and bolts for firm seating and re-tighten them as necessary.

If electrical welding is used on the tractor and on the attached sprayer, disconnect the cable to the tractor's alternator and battery before carrying out electrical welding work on the tractor and on the connected sprayer. Remove all inflammable or explosive materials from the area to prevent fire.

Pressure test the spray functions with clean water prior to filling with chemicals.

Do NOT disconnect hoses, pipes, or any equipment, if the sprayer is in operation!

Stay below the maximum speed (RPM) suitable for the PTO shaft.

When replacing spare parts, use suitable tools and personal protective equipment.

Spare parts must at least meet the specified technical requirements of HARDI. This is ensured through the use of genuine HARDI spare parts.

Important Info

Intended Use

Your HARDI sprayer is intended for transportation, mixing, and application of crop protection and liquid fertilizer on agricultural areas, and it is designed for that specific task only.

Complying with instructions and with the general safety and responsibility notes ensures the performance and longevity of the sprayer. Besides compliance with instructions, the intended use includes observing all pictograms and warnings on the machine; execution of all maintenance and repair intervals; complying with the defined technical limits and areas of application; and exclusive use of genuine HARDI spare parts.

Any other kind of use of the machine contradicting the above is considered as not intended, especially:

- Attachment to an agricultural tractor that is not suitable.
- Filling the machine with fluids other than those approved in the scope of the instructions.



NOTE! Fluids with high acidity are not recommended. Please see "Before Putting the Sprayer into Operation" on page 73.

- Exceeding the permissible technical total weight or weight of its sub-components.
- Operating the machine while persons are still in the danger zone, see "Working Area of the Sprayer" on page 35.
- Carrying out maintenance and/or repair work on a machine that has not been shut down or is not secured against

restarting.

When driving the machine in public road traffic, the operator must comply with the national and local road traffic regulations. Moreover, the operator must adjust the driving speed to the prevailing conditions. Also, field conditions and spraying speed are important factors that must be considered to ensure the well-being of the machine.



WARNING! Irresponsible driving in rough terrain, whether in field or in transport, is considered as not intended as it will impact the machine negatively: It may result in overloading and premature stoppage, poor spraying performance, and could even provoke dangerous situations to your safety and health.

Therefore, it is recommended to handle the machine with care and always to pay attention to unusual behaviour, to unintended changes of functions, or to minor defects that needs immediate attention.



NOTE! We strongly recommend that the operator is trained in correct plant protection and in safe handling of plant protection chemicals to prevent unnecessary risk for persons and the environment, when carrying out your spray job.

For any damage resulting from unintended use, as mentioned above:

- The owner and the operator bear the sole responsibility, see "Before First Use of the Sprayer" on page 10.
- HARDI AUSTRALIA does not assume/accept any liability including warranty coverage.

3 - Technical Description

Lifetime

The expected lifetime for the sprayer is upto 10 years depending on use, conditions and maintenance.

A sprayer's expected lifetime is the subject of multiple factors:

- Operating conditions and care of use
- Hours per year of operation
- Variations of agrichemicals used
- Service and Maintenance completed in a timely manner
- Cleaning the Sprayer
- Use of original parts

To obtain this successfully, these instructions should be followed:

- All service and maintenance work must be completed in due time
- Repair any damaged parts as quickly as possible
- Replace or change spare parts as instructed
- Only use original HARDI spare parts



ATTENTION! If using acidic liquid in a spray boom with stainless steel piping, this will shorten the lifetime significantly, as these pipes are not acid-proof. Risk of corrosion and leaks.

Operating Limits

The following things are important when considering the performance of the sprayer.

- Maximum driving speed
- Pressure setting
- Minimum/maximum volume rate

The operating limits for your sprayer are closely related to:

- Pump size
- Boom width
- Nozzle size

In the table below, the operating limits for volume rate are calculated, when driving at different speeds.

Nozzle Size	Min. Volume Rate (l/ha)				Max. Volume Rate (l/ha)				
	HARDI ISO F-110	4 km/h	8 km/h	12 km/h	16 km/h	4 km/h	8 km/h	12 km/h	16 km/h
02 (yellow)		171	85	57	43	309	155	103	77
025 (purple)		213	106	71	53	387	194	129	97
03 (blue)		255	127	85	64	465	232	155	116
04 (red)		339	170	113	85	621	310	207	155
05 (brown)		423	212	141	106	774	387	258	194
06 (grey)		510	255	170	128	930	465	310	233
08 (white)		678	339	226	170	1239	620	413	310
10 (light blue)		849	424	283	212	1548	774	516	387



NOTE! The specified nozzle type is a standard flat fan nozzle. Other special nozzle types will show different results. Ask your HARDI dealer if in doubt.



ATTENTION! It is recommended not to drive faster than 16 km/h when spraying.



ATTENTION! The pressure range for the nozzles are 1.5 - 5 bar (except for HARDI INJET nozzles, which are ranging from 3-8 bar). The spraying pressure should be within these limits.

3 - Technical Description

Liquid Fertilizer

Spraying Pressure

If you are spraying with liquid fertilizer instead of pesticides, the spraying pressure must be increased in comparison to pesticide spraying to get the desired output (l/ha).

The specific gravity for liquid fertilizer is normally higher than for water and spray liquids - so to get the correct output (l/ha), the spraying pressure must be adjusted.

Example:

Nozzle output is 2.40 l/Min at 3.0 bar pressure. Specific gravity of liquid fertilizer is 1.20 g/cm³.

Multiply the pressure value with the specific gravity value: $3.0 \times 1.20 = 3.6$.

The adjusted pressure is now 3.6 bar for spraying the liquid fertilizer.

In the table below, adjusted pressure values can be found for different specific gravities of liquid fertilizers.

	Specific gravity (g/cm ³) for Liquid Fertilizer				
	1.10	1.15	1.20	1.30	1.40
Calibrated Pressure (bar) when Spraying with Pesticides	Adjusted Pressure (bar) when Spraying with Liquid Fertilizer				
1.5	1.7	1.7	1.8	2.0	2.1
2.0	2.2	2.3	2.4	2.6	2.8
2.5	2.8	2.9	3.0	3.3	3.5
3.0	3.3	3.5	3.6	3.9	4.2
3.5	3.9	4.0	4.2	4.6	4.9
4.0	4.4	4.6	4.8	5.2	5.6
4.5	5.0	5.2	5.4	5.9	6.3
5.0	5.5	5.8	6.0	6.5	7.0



ATTENTION! Pressure values below 1.5 bar or above 5.0 bar are considered to be out of range for the nozzles.



NOTE! Find the specific gravity for your liquid fertilizer on the packaging or on the material safety data sheet (MSDS) included.

TankGauge in MainTank

When the MainTank is filled with liquid fertilizers that has higher specific gravity, the TankGauge may show incorrect values. Therefore the specific gravity for the TankGauge need to be corrected.

1. In the controller, go to menu [3.5.1 Adjustment of specific gravity].
2. Set specific gravity.
3. Press Enter to confirm.

Product Description

Front View

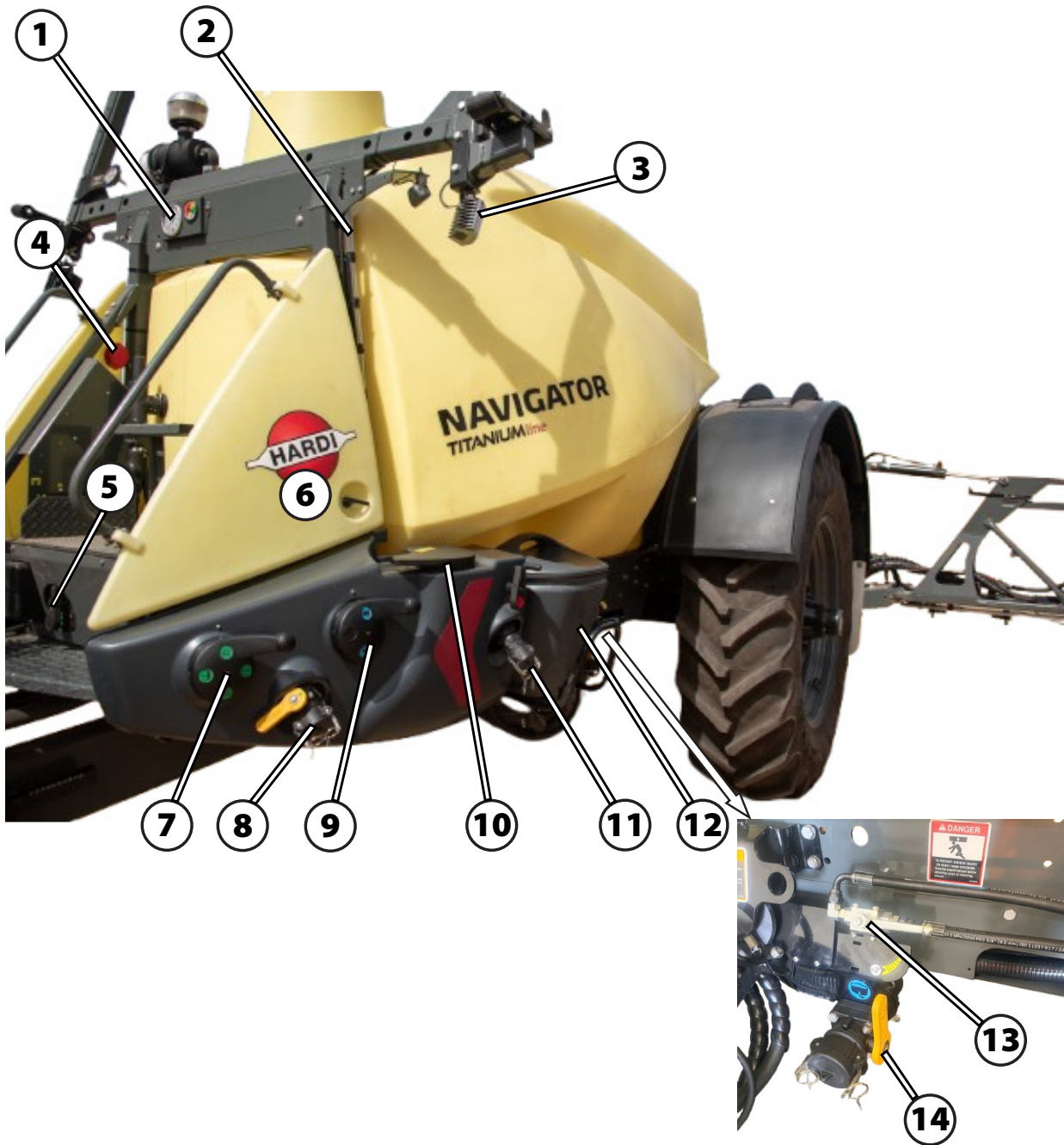

- | | |
|----------------------------------|---------------------------------|
| 1. Spray Pressure Gauge | 8. Cleanwater fill point |
| 2. Level Indicator for RinseTank | 9. Suction Valve |
| 3. Work light | 10. Cyclone Filter |
| 4. Lid for Clean Water Tank | 11. Chemical fill point |
| 5. Agitation Valve | 12. TurboFiller (VACnMIX) |
| 6. SafetyLocker | 13. Control valve for Banjofill |
| 7. Pressure Valve (SmartValve) | 14. Tank drain valve |

3 - Technical Description

View

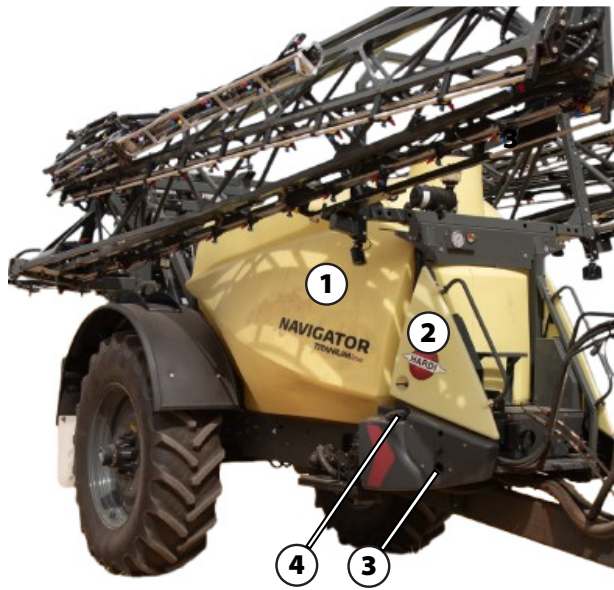

- 1. MainTank
- 2. CleanWaterTank
- 3. Storage Position for Support Leg



- 4. CycloneFilter
- 5. RinseTank
- 6. Air tank

Platform

Components Around the Platform

- A. EasyCleanFilter clogging indicator
- B. Rails for support
- C. Platform
- D. DynamicFluid4 pressure regulation valve.
- E. Air compressor
- F. Liquid pump
- G. Optional hydraulic motor for liquid pump
- H. Steps

Accessing the Platform

1. Swing the step out (H), until it clicks into the locked position.
2. Place your foot on the step while holding on to both rails (B).
3. Step up on the platform (F).
4. When back on the ground, push the step away (H) by pulling it up and swing it back to the locked position.

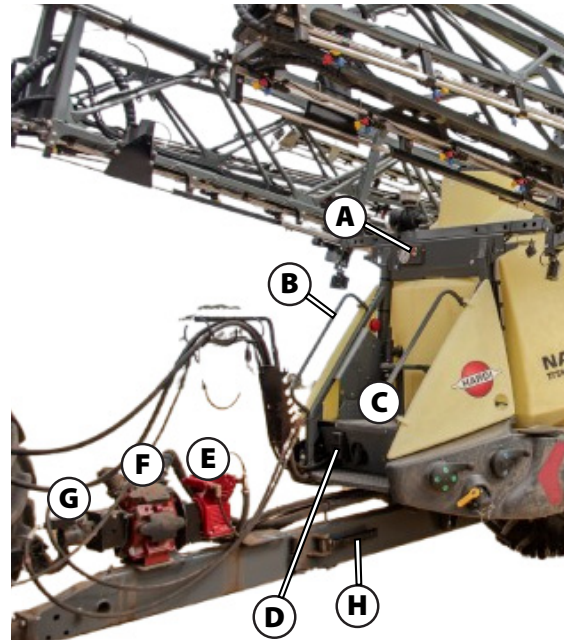

3 - Technical Description

Right Side Cover

The right side cover is opened by turning the handle in the lower left corner of the cover and lifting the cover up.

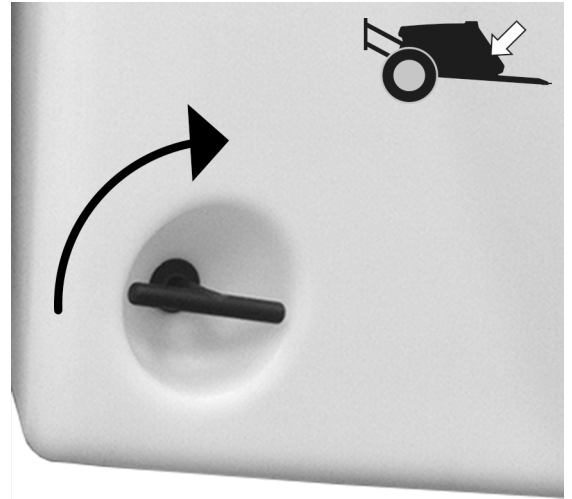

Main Components

- A. SmartCom ECU.
- B. Power Distribution Unit for SmartCom.
- C. CleanWaterTank, integrated in the side cover. The CleanWaterTank is filled at the lid (arrow), when the side cover is closed.



ATTENTION! Only open the right side cover, when the CleanWaterTank is empty!

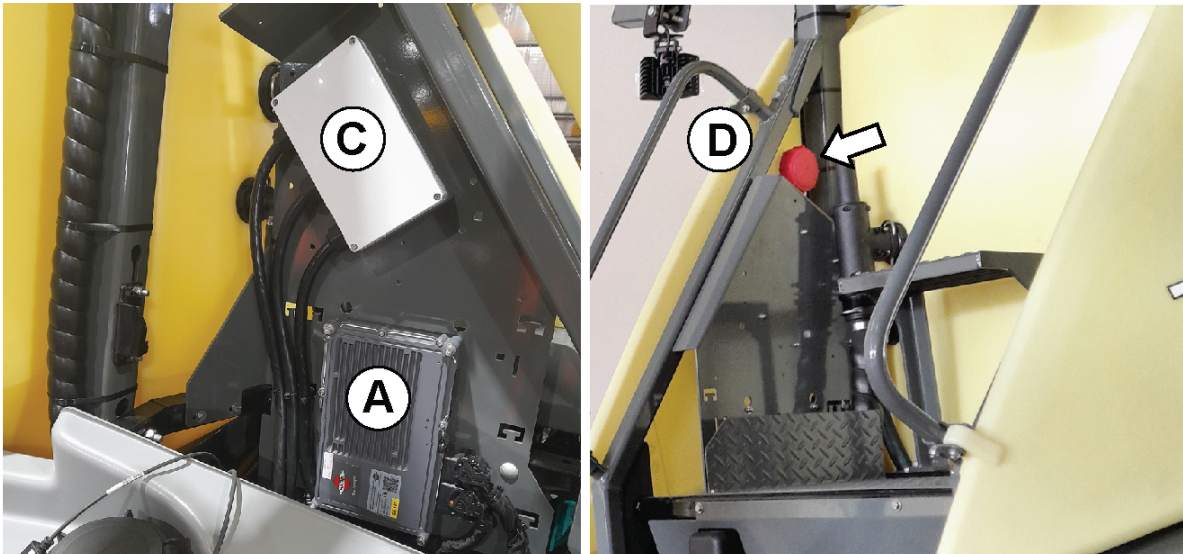

NOTE! There can be an optional electric junction box for road lights.

Dimensions and Specifications

General Info

All measures, values and weights are depending on mounted options and specific adjustments.

Overall Dimensions and Specifications

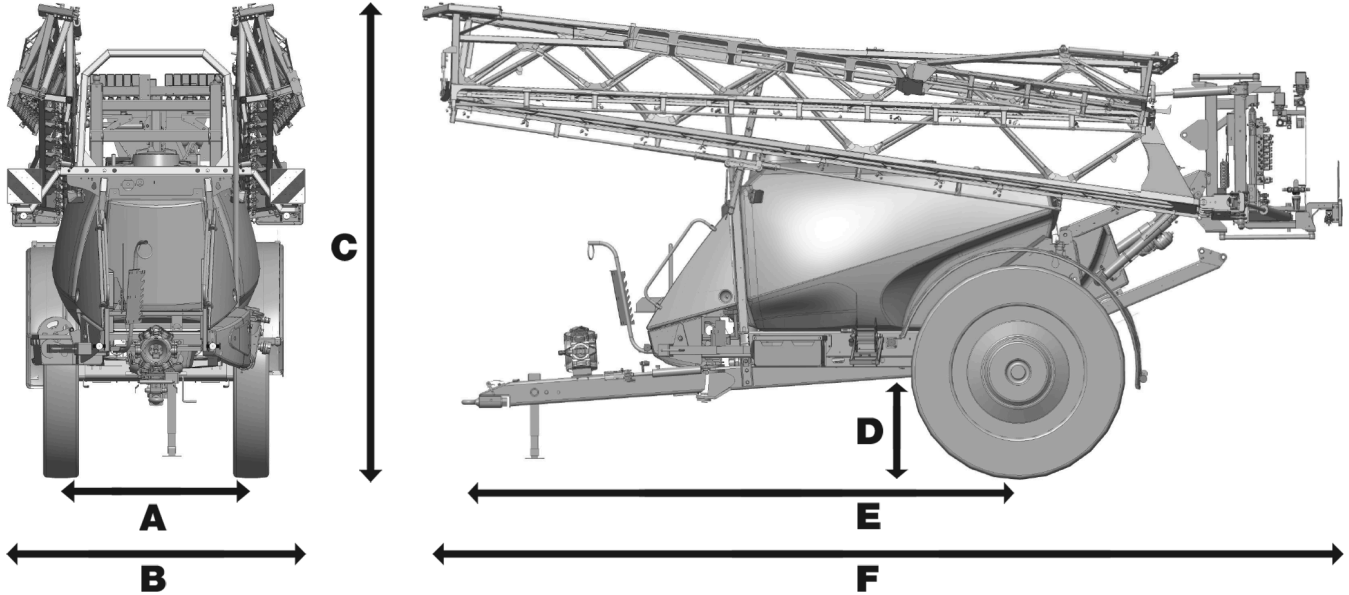

Dimension (meter)		4000l	5000l	6000l
A	Track width	1.8 -2.5		
B	Transport Width	2.4 -3.5		
C	Total Height	3.5 - 4.0		
D	Ground Clearance at Axle	0.7 - 0.85		
E	Length Drawbar to Axle	4.3 - 4.9	5.3 - 5.6	
F	Total Length	7.1 - 7.6	7.1 - 7.6	

Weight

Conditions for the weight indication in the table below are as follows:

- Full MainTank (normal volume), full RinseTank and full CleanWaterTank
- Tjhe hitch load indicates weight at the hitch eye
- The boom is in transport position

Weight (kg)	4000l	5000l	6000l
Total weight (empty tank)	4300 - 4800	5300 -5800	5350 - 5900
Axle load (empty tank)	3800 - 4150	4600 - 4900	4650 - 4950
Hitch load (empty tank)	100 - 500	700 - 950	700 - 950
Total weight (full tank)	8300 - 9350	10500 - 11100	11550 - 12150
Axle load (full tank)	7000 - 7650	8600 - 8950	9300 - 9650
Hitch load (full tank)	1300 - 1700	1900 - 2150	2250 - 2500

NOTE! There can be a weight difference of up to ± 300 kg, depending on sprayer specifications and configuration.

3 - Technical Description

Temperature and Pressure Ranges

Spray Liquid System

Operating temperature range	2 - 40 °C
Operating pressure for the safety valve	15 bar ±1 bar
Operating pressure for the External Cleaning Device safety valve	10 bar ±1 bar
Max. pressure on the pressure manifold	20 bar
Max. pressure on the suction manifold	1.5 bar

Transmission Shaft

Options at the tractor hitch point:

A Dimension: 1 3/8" (35 mm)

1. Yoke with 6 splines.
Normally used for pump working speed = 540 RPM.
2. Yoke with 21 splines.
Normally used for pump working speed = 1000 RPM.

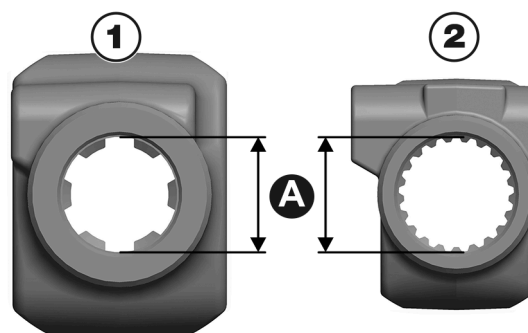

The tractor must follow the international standard ISO 500-1:2014 regarding general specifications, safety requirements, dimensions for master shield and clearance zone for rear-mounted power take-off types 1, 2, 3 and 4 on agricultural tractors.



Hydraulic Couplings

Coupling Size	Sprayer Equipment	International Standard	Coupling Type
3/8"	Movement of spray boom, Y-type (tractor has separate outlets for each movement). Oil drain for AIR STREAM system blower.	ISO 7241:2014 regarding dimensions and requirements of 1/2" quick-action couplings for hydraulic fluid power	
1/2"	Movement of spray boom, Z-type (tractor has one outlet for all boom movements, which are controlled separately by electronics)		
1/4"	Load sensing (LS)		

CE Vehicle Rating Plates

Fitted on the steel frame near the front right-hand side of the sprayer, is a vehicle identification plate indicating sprayer VIN. In addition, find the sprayer Vehicle Identification Number (VIN) punched into the steel frame near the vehicle rating plate. The example to the right is the international model of the vehicle rating plate.

VIN plate

An identification plate is fitted near the front right hand side of the chassis on the sprayer. The reference number on plate will help you and your HARDI dealer to clearly identify your machine and assist in the correct supply of spare parts and service information.



ATTENTION! The identification plate is regulatory, it should always be in place on the sprayer. For all information about the machine, please quote the serial number of the sprayer.

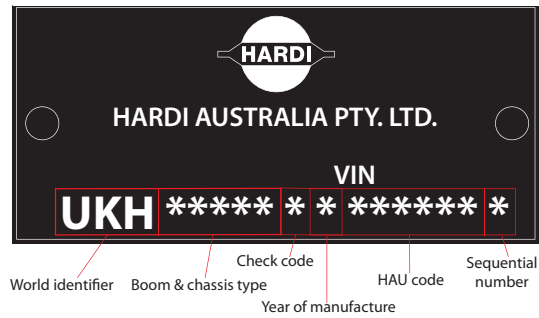

3 - Technical Description

Spray pump

Pump

Diaphragm pump with 6 diaphragms, model 364.

The design of the diaphragm pump is simple, with accessible diaphragms and valves, which ensures that liquid does not contact the vital parts of the pump.

Pump model 364 is shown in the picture.

Pump Flow Rate: 194 litres/min

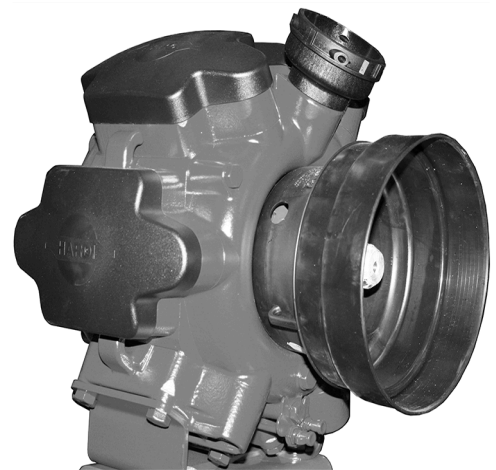

Ace Centrifugal pump (Optional)

Ace Oasis Wet Seal Technology prevents the pumped liquid from contacting the shaft seals. The seals operate in a reservoir filled with a specially formulated barrier fluid for seal face lubrication and heat dissipation. Additionally, air pressure is introduced to prevent pump fluid from contaminating the seal reservoir. This isolation of the seals prevents abrasive wear of the seal faces and run dry seal failures.

Flow Rate: 650 litres/min

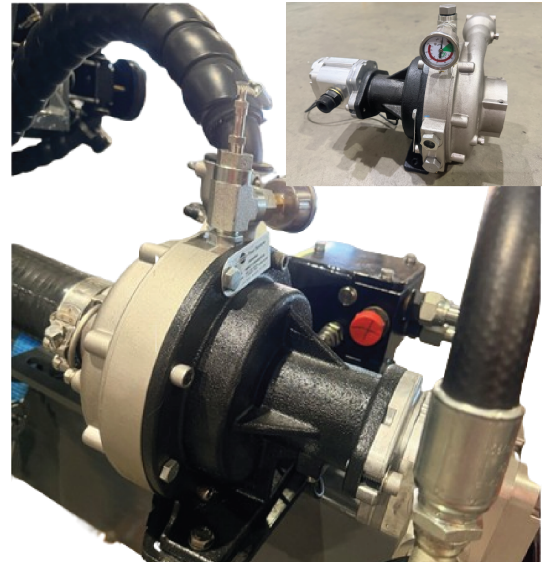

Pump Capacity

The type signs for the pumps in the previous section show theoretical values only.

The pump performance is impacted by the fluid system it is working within, giving the actual pump the following approximate performance rates ($\pm 5\%$).

Pump Capacity Testing

Testing the pump must be carried out according to the international standard ISO 16122-2 or later revisions and substitutes.



ATTENTION! Always conduct scheduled pump capacity tests in accordance with local laws and regulations.



NOTE! Contact your HARDI dealer for more information.

Liquid System

Tank Volume Sensor

MainTank

The actual liquid level in the MainTank can be observed on the screen (A), the level is indicated by a sensor fitted at the bottom of the tank.



ATTENTION! The level indicator is only a guidance for the liquid level in the tank. For the most accurate reading, park the sprayer on level ground with the sprayer chassis in a horizontal position.

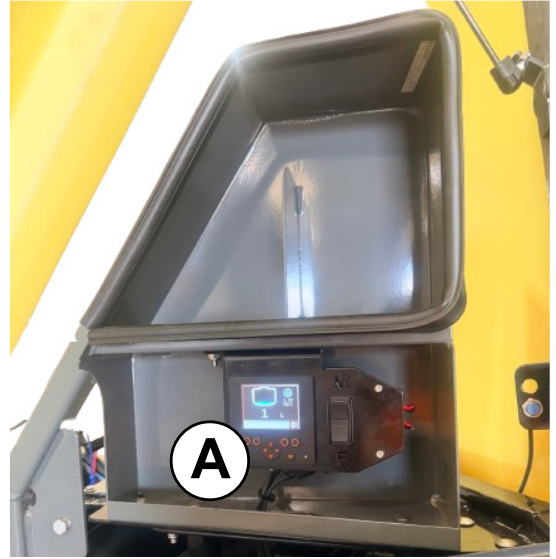

RinseTank

The actual water level in the RinseTank can be observed in the tube (B). A yellow ball floating inside the tube indicates the water level.

- The ball is at the top of the tube: A full tank.
- The ball is at the bottom of the tube: An empty tank.

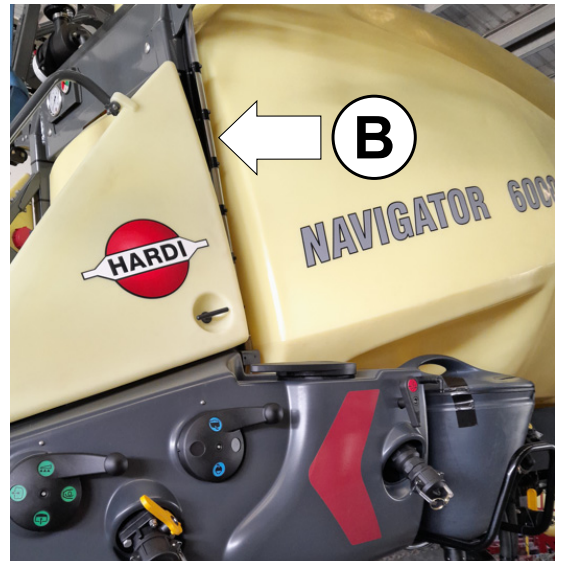

3 - Technical Description

TurboFiller

The TurboFiller is where you add the chemicals to be mixed with water in the MainTank.

Capacity: approximately 35 litres.

By operating the levers (A) on the side of the TurboFiller (B), you can do the following:

- Stir up the added chemicals with water from the sprayer.
- Transfer the mix to the main tank.
- Clean your chemical container or the TurboFiller (B) inside by using the flushing nozzle.

A spray gun (C) is also available for further cleaning.

The TurboFiller can be raised and lowered by using the latch (D).

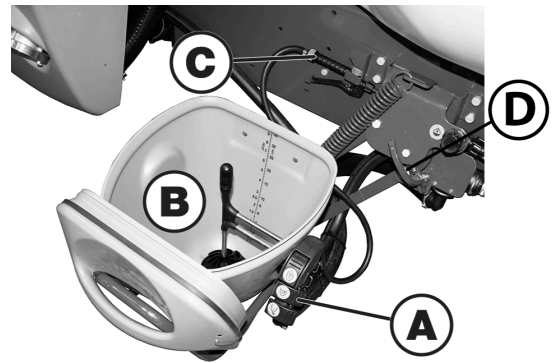

DynamicFluid4 Pressure Regulation

Traditional fluid regulation starts, when the nozzles are opened. With DynamicFluid4 the regulation is a continuous process, even if the nozzles are closed.

The DynamicFluid4 system is based on 5 sensors that the sprayer computer uses to calculate an optimal regulation. The sensors are also back-up for each other, ensuring that the system can continue regulation - even if one or more sensor signals fails.

The applied 5 sensors measure:

1. Driving speed.
2. Pump RPM.
3. Regulation valve opening angle.
4. Fluid flow.
5. Fluid pressure.

DynamicFluid4 uses the following parameters/variables to regulate:

- Driving Speed.
- Pump RPM.
- Active Sections.

Then DynamicFluid4 starts to move the regulation valve towards the calculated final position, immediately after the operator makes any changes.

During the spray job, there are two scenarios:

Nozzles ON

The sensor input to the regulation system is live.

Nozzles OFF

A simulation of the previous spray situation now is basis for the regulation. Called FeedForward and it foresees the correct opening of the regulation valve. Thereby it is extremely fast to obtain the correct application rate when opening the nozzles.

Even when closing all but one nozzle on a very wide boom, it is quick to achieve the correct and stable application rate. The benefit is more precise application rates immediately when spraying begins.

Features for DF4

- The pressure regulation, quick reaction and zero bypass is ensured by
- Very fast and accurate regulation when all sensors are active, controller configurations are correct, and pump, filters and valves are in good condition. The system measures and calculates 20 times per second.
- Quick reacting valve, when turning sections On/Off, and as speed changes.
- Optimized AutoSectionControl feature that predicts boom section openings and optimizes nozzle pressure.
- Optimized for different pump drive systems.
- Nozzle surveillance. No setup or tuning is required for nozzle change.
- Controller display can show the current nozzle output, which compares with the rated output. A significant difference in output is caused by failures occurring in' the liquid system, such as:
 - Severe clogging of filters.
 - Large leakages on hoses and fittings.
- All functions work, though with degraded performance (limp-home modes), if:
 - Failures occur in the fluid system, e.g. pump defects, clogged filters or leaking valves.
 - Failures occur on the pressure sensor, flow sensor or pump sensor.
 - There is a wrong setup of sprayer data in the menus.

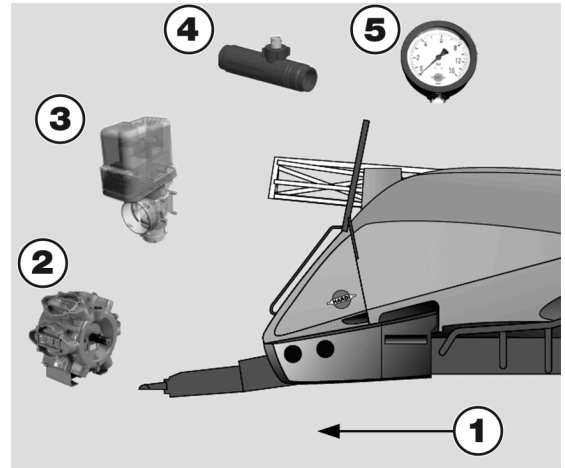

3 - Technical Description

Valves and Symbols

The possible functions of valves are distinguished by coloured identification on the function labels. The modular valve system facilitates the addition of optional extras on both pressure side and suction side.

A function is activated by turning the handle towards the desired function.

 ATTENTION! Only the functions used should be open - always close remaining valves.

 ATTENTION! If a valve is too tight to operate, or to loose (= liquid leakage, the valve needs to be serviced. Please see "3-Way Valve Adjustment" on page 166 for further information.





Pressure SmartValve (Green Symbols)

This valve is to select which function the pressurized liquid from the pump will be routed to.

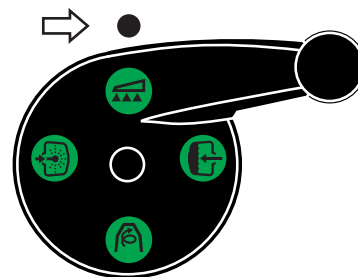
The active function is indicated by the indicator.

The handle is turned so the desired symbol is just below the black mark. If the handle is turned to a position without label with a symbol (unused function), the valve is closed.



- | | |
|--|---|
|  Chemical suction point |  Spraying |
|  Tank cleaning |  TurboFiller |

Suction Valve (Blue symbols)

This valve is to select suction from main tank or from rinsing tank.

The handle is turned so the desired symbol points to the black mark. If the handle is turned to a vertical position, the valve is closed.

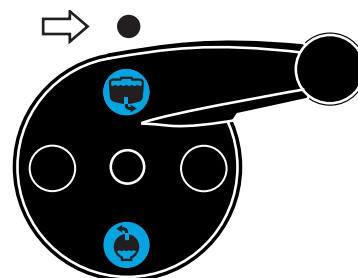

- | | |
|---|--|
|  Main tank |  Rinsing tank |
|---|--|

Agitation Valve (Green symbols)

With the manually adjustable agitation valve it is possible to combine spraying with a high volume rate at high pressure with agitation at the same time.

This is controlled continuously by the valve: The valve is marked with an arrow on the disc which indicates the amount of liquid that passes through the valve.



Adjustable agitation

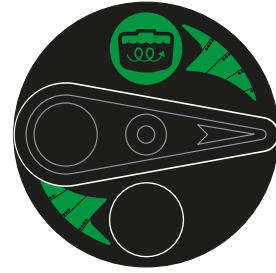

Choose your own valve setting, depending on the tank contents:

- The handle is turned to a position near the tip of the arrow:

Only a small amount of liquid is allowed to pass the valve resulting in a lesser extent of agitation. This is recommended when using chemicals with a low density to prevent foaming in the tank.

- The handle is turned to a position in the wide end of the arrow:

A large amount of liquid will pass the valve resulting in a large extent of agitation. This is recommended when using chemicals with a high density, which will tend to settle at the bottom of the tank.

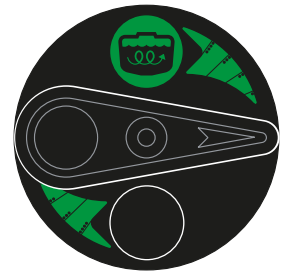

3 - Technical Description

Filters

Filters on your sprayer are there to protect components and prevent nozzle clogging.

- An EasyCleanFilter (suction) is fitted in the working zone.
- A SelfCleaningFilter (pressure) is fitted on the sprayer's right side just below the yellow side cover. It has a built-in self-cleaning function.
- In-Line filters (pressure) can be fitted at each boom section.
- Nozzle filters may be fitted at each nozzle.
- A coarse filter is located below the top cover for the MainTank.

Filter Mesh

The higher the number of mesh, the finer the filtration.

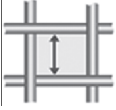
		Filter Name/Position							
		Mesh	Mesh Size	Colour	EasyCleanFilter	CycloneFilter	In-Line	Tank Strainer	Nozzle
		18	1.00 mm	White	-	-	-	Yes	-
		30	0.58 mm	Green	Yes	-	-	-	-
		50	0.30 mm	Blue	Yes	-	Yes*	-	Yes*
		80	0.18 mm	Red	Yes	Yes	Yes*	-	Yes*
		100	0.15 mm	Yellow	-	-	Yes*	-	Yes*

*depending on selected nozzles



ATTENTION! All the filters should be in use and their functionality must be checked regularly. Pay attention to the correct combination of filter and mesh size. For more information, see the chapter "Technical Specifications" in this book.



ATTENTION! Always operate your sprayer with clean filters to ensure proper functions and to protect the interior of the pump and valves.

EasyCleanFilter (For 364 pump)

This filter collects impurities, when liquid is being sucked out of the main tank by the main pump.

To ensure proper function of the filter and its built-in valve, the filter must be opened at least once every month. A label on the lid also designates this.



NOTE! This is removed when the Ace centrifugal pump option is selected.

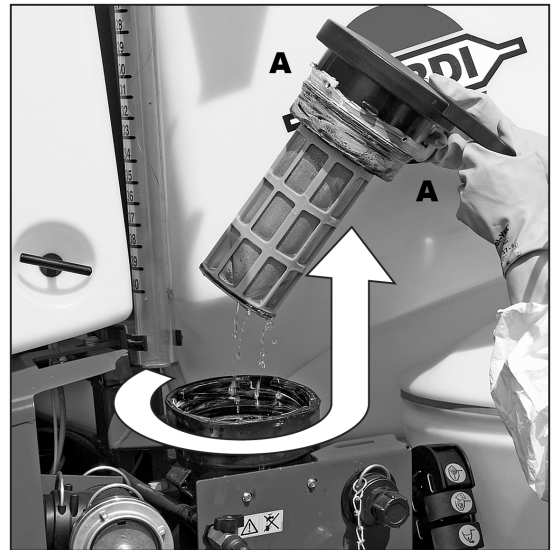

Besides the spray pressure gauge a clogging indicator is installed. This works as a vacuum gauge for the filter during operation - the pointer moves from green towards red, if the filter starts clogging.

Clogging Indicator	Filter Condition
Green area	70 - 100 % capacity. No cleaning necessary.
Yellow area	55 - 70 % capacity It is possible to finish an ongoing spray job and then clean the filter afterwards.
Red area	0 - 55 % capacity Clean the filter immediately, as it is clogged too much for proper function.

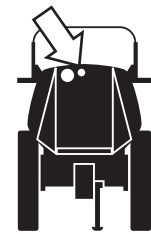

3" suction filter (For Ace pump)

The 3-inch suction filter is installed on the bottom right hand side of the drawbar to protect the pump from debris and contaminants. It prevents foreign particles such as dirt, solids, and residue from entering the pump, reducing wear and minimizing the risk of blockage or damage.

The filter helps maintain consistent flow and efficient pump performance, while extending the service life of the pump components. It is designed for easy inspection and cleaning as part of routine maintenance.



3 - Technical Description

CycloneFilter

With the CycloneFilter, any impurities in the spray liquid will be cleaned out and returned to the MainTank via the return flow.

Function diagram:

1. Filter lid
2. Piping from pump
3. Piping to boom
4. Return to tank
5. Boost valve

The boost valve (5) has three positions marked with small dots on the lever:

- A. This position is marked with 1 dot:

There is no return flow. This position is used when rinsing the boom, if there is spray liquid in the MainTank. Also used when high spraying volume is required.

- B. This position is marked with 2 dots:

Normal position when spraying. With return flow to prevent filter from clogging during spraying. This position is used when rinsing the boom, if the MainTank is empty.

- C. This position is marked with 3 dots:

Flushing position which is used if the filter is clogged. Lift and hold the lever to use this position, which largely increases return flow and flushes the filter. The pressure SmartValve must be set for "Spraying".

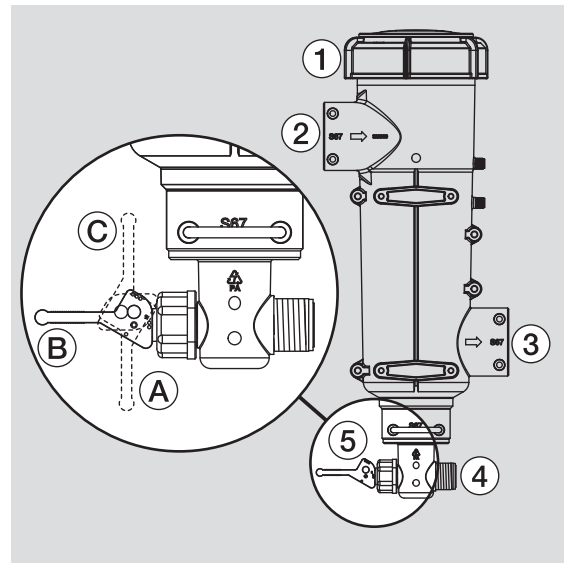

ATTENTION! Use of position C is no guarantee for a clean filter. Always do a visual inspection and cleaning of the filter. For more about cleaning, see the section "10 Hours Service - CycloneFilter" on page 116.



DANGER! Never open the CycloneFilter unless the suction valve is closed and the pressure SmartValve is set to "MainTank". Otherwise spraying liquid may hit you, when opening the filter, and this will also drain the MainTank!

3 - Technical Description

RinseTank

One RinseTank is rear of the sprayer behind the MainTank. The tank is made of impact-proof and chemical resistant polyethylene. It is used for rinsing and flushing of the MainTank and liquid system.

Filling is done via the 1½" CamLock fitting placed in the working area. The RinseTank level indicator is placed at the platform.

Capacity: approximately 450 litres.



Clean water tank

A clean water tank is integrated into the right side cover. It is accessed for filling at the sprayer's right side when entering the platform. The tap for clean water tank is located in the work zone.

The water in this tank is for hand washing, for cleaning of clogged nozzles etc. Only fill this tank with clean water from the tap.

Capacity: approximately 20 litres.



WARNING! Not for drinking!



WARNING! This water must never be used for drinking water.



3 - Technical Description

ActivAir (Optional)

Air compressor

General Info

The air compressor is a compact V-type reciprocating compressor engineered for efficiency and durability to deliver superior performance.

The air compressor is able to deliver a continuous air supply for the operation of the Active-Air system. A crankcase breather tube is connected to the air intake to prevent blockage from dust and debris and to extend the life of the compressor.

Max Pressure: 118psi/ 8bar



i NOTE! ISO 100 grade oil (600 ml) is provided for lubrication.

Air tank

General Info

The air tank is used to store high-pressure air supplied from the compressor. The tank is fitted with a drain and relief valve to protect the system from over pressure and to allow moisture to be drained from the system as required.

Capacity: 30Litres

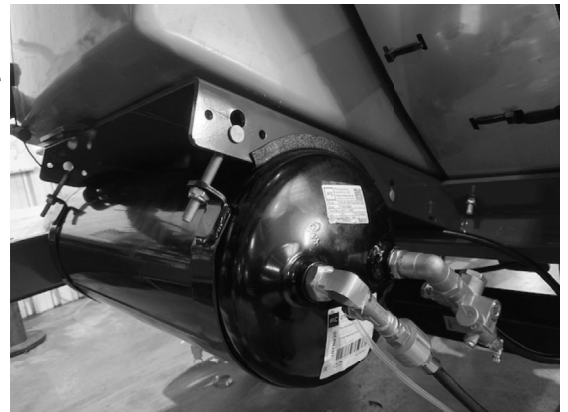

Unloader valve

General Info

The function of the unloader valve is to release the remaining air from the compressor and the relative lines when the air system reaches the maximum set pressure. It is fitted to the inlet side of the air receiver located at the rear of the machine.

- A. Inlet port (Compressor)
- B. Vent Port (Open To Atmosphere)
- C. Outlet Port (Tank)
- D. Unloading Lever
- E. Range Adjustment Screw
- F. Range Lock Nut
- G. Differential Adjustment Screw
- H. Differential Lock Nut

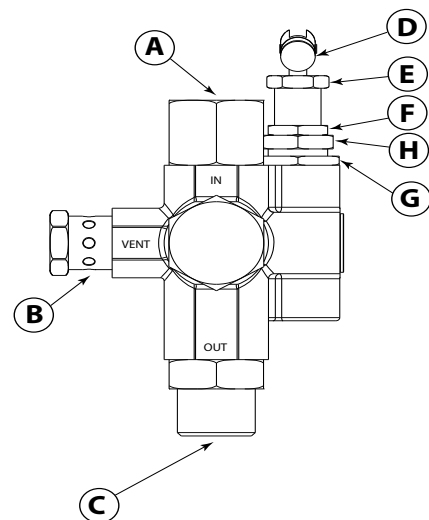

Air filter assembly

General Info

The air filter assembly is fitted to the top of the transport frame and consists of two parts. A pre-cleaner which is installed in the highest part of the intake system and an air-cleaner.

The pre-cleaner removes most of the contamination and dirt from the incoming air and is effective at removing larger dirt particles and water droplets. A full-view plastic bowl lets the operator easily see when a service is required.

The air-cleaner consists of an outer pleated cartridge (28109804), an inner synthetic spun-bonded cartridge (28109904) inside a polymer housing. The outer cartridge removes the remaining dust and debris from the air before it enters the air compressor.

The inner cartridge (also known as the safety filter,) provides protection for the compressor in the event of a failure of the outer cartridge.



3 - Technical Description

Spray Boom

General Info

The DELTA FORCE boom (DDZ) is:

- Pendulum suspended.
- Operated in a strong and stable parallelogram-shaped boom lift, called ParaLift.
- DDZ type: Fully hydraulic operated with all functions controlled via the direct hydraulic system (DH).
- Having a working width of 24, 28, 30 or 36 metres, depending on the delivery.

Terminology

For 3-folded booms, the terminology is as follows:

- A. Centre section
- B. Inner wing
- C. 1st outer wing
- D. 2nd outer wing
- E. Breakaway section

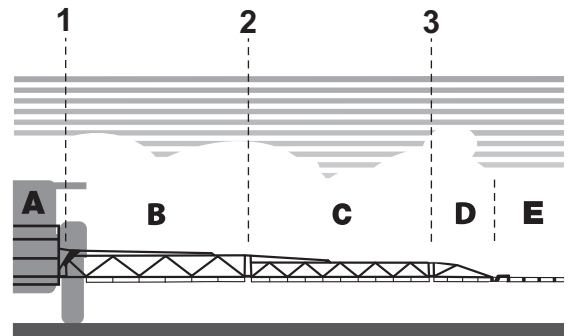

For 2-folded booms the terminology is as follows:

- A. Centre section
- B. Inner wing
- C. Outer wing
- E. Breakaway section

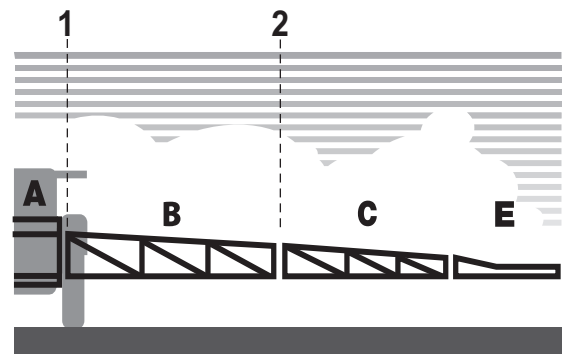

Standard Boom Features

A. Individual tilt of boom wings.

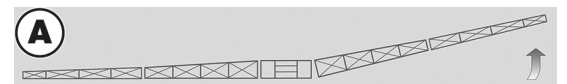

B. Two types of folding, depending on the delivery:

- 2-folded wings for:
24, 28 and 30 metre boom widths.
- 3-folded wings for:
36 metre boom width.

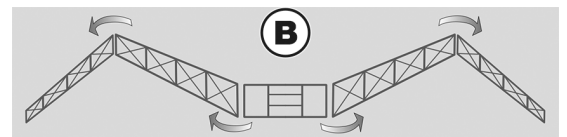

C. The boom may be used with alternative boom widths:

- 1/2-folded boom width.
- 2/3-folded boom width (3-folded booms only).

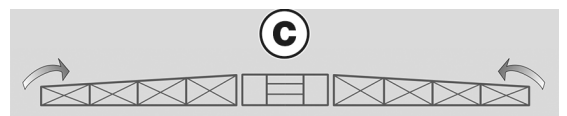

3 - Technical Description

D. Spring-loaded breakaway section.



E. Hydraulic boom lock.

1. Hydraulic Lock.
2. Lock Knob.

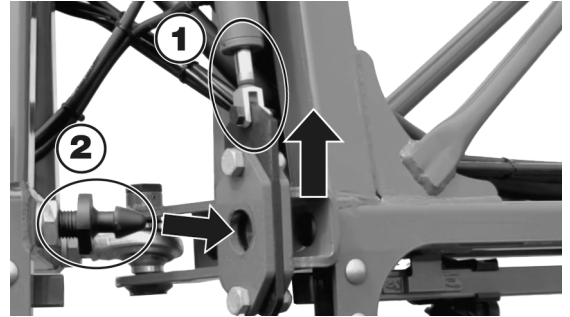

Available Working Widths

A	B	C
Full Working Width (metres)	2/3 Boom Width (metres)	1/2 Boom Width (metres)
24*	-	15
28*	-	15
30*	-	16
36	28	16

*2-folded booms.



3 - Technical Description

Electrical Connections

Power Supply

The power requirement is 12 V DC. Always note the polarity!

For proper function of the electric equipment for the sprayer, the tractor must have the following sizes of electric wires installed.

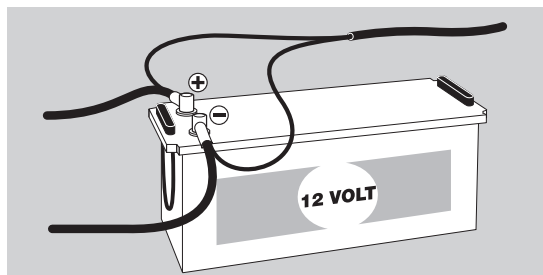

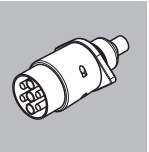
 <p>ISOBUS Connector, 9-pin Plug</p> <p>The unit requires: Wire $2 \times 10 \text{ mm}^2 + 2 \times 2.5 \text{ mm}^2 + 2 \times (2 \times 0.5 \text{ mm}^2)$</p> <p>The cable is custom made and must not be changed to another type.</p> <p>Tractor must follow ISO 11783-2.</p> <p>Cabin connector for Grip control and SetBox:</p> <p>HARDI item no. 26031500</p>	 <p>Traffic Light Connector, 7-pin Plug (Optional)</p> <p>The unit requires: Wire $6 \times 1.5 \text{ mm}^2 + 1 \times 2.5 \text{ mm}^2$.</p> <p>The cable is custom made and must not be changed to another type.</p> <p>Tractor must follow AS 4177.5-2004.</p>
--	---

i NOTE! The delivered power connectors follow the standard of most modern tractors. If you have a tractor with another power connector, it is necessary to disassemble the connector and fit it to the actual sprayer connector. Contact your HARDI dealer.

i NOTE! The delivered connectors may vary on the sprayer, depending on its equipment and scope of supply.

Hydraulic System

Hydraulic Blocks

Hydraulic blocks installed on the sprayer are described below.

Spray Boom

The main hydraulic block which distributes hydraulic fluid for the boom controls.

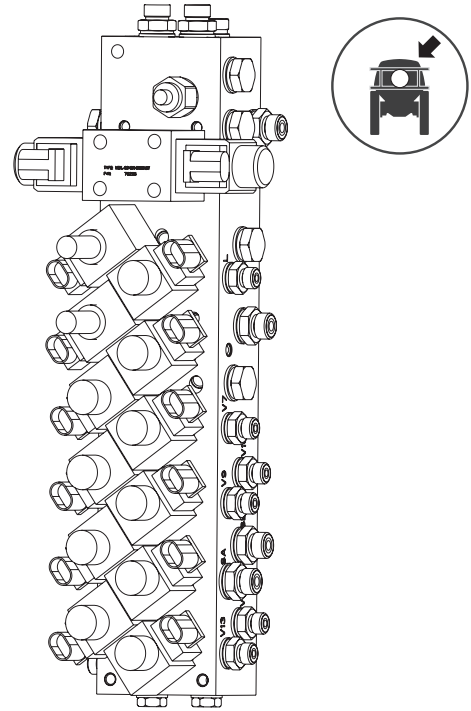

ParaLift

This hydraulic block distributes hydraulic fluid for the ParaLift when raising or lowering the spray boom.

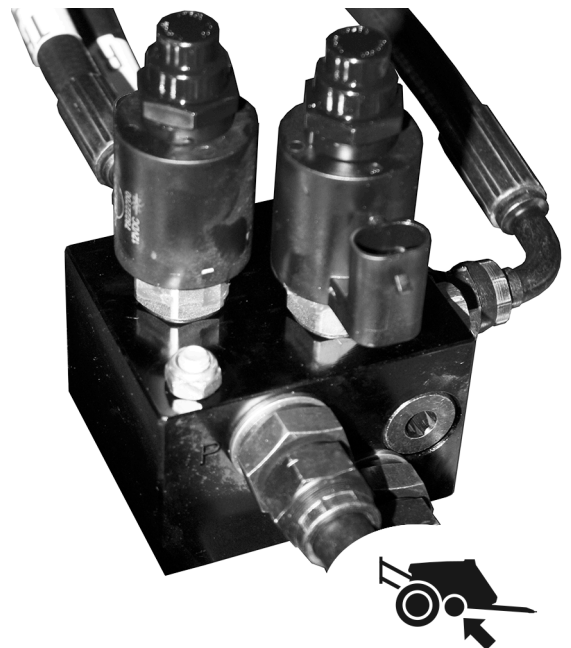

3 - Technical Description

Open Centre Hydraulics

The open centre hydraulics block is necessary, if the tractor uses open centre hydraulics and/or load sensing.

If in doubt whether your tractor uses open or closed centre hydraulics, see the tractor's instruction book or ask your tractor dealer.

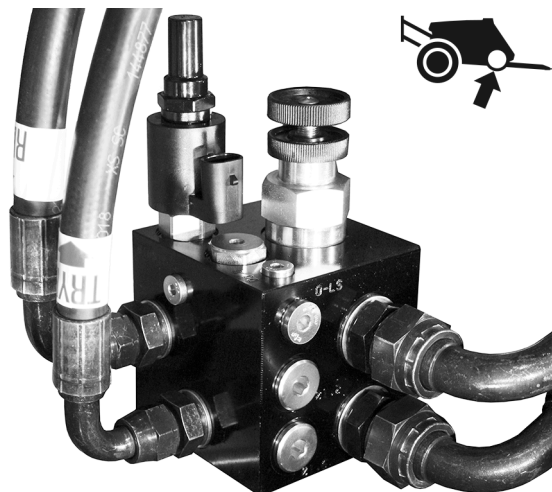

Hydraulic Filter

The filter helps ensure smooth and reliable performance of the sprayer's hydraulic functions, reducing wear and preventing potential damage. Regular inspection and replacement of the filter are required to maintain optimal system performance and longevity.



AutoHeight

This hydraulic block distributes hydraulic fluid for the automatic control functions for boom height during spraying.

The AutoHeight function has three valves marked with arrows.

The AutoHeight system uses ultrasonic sensors along the boom to measure the working height of the boom from the ground.

This process happens continuously as the sprayer moves across uneven terrain to keep the boom at the desired height.

 NOTE! Please refer to Norac manual for more information.

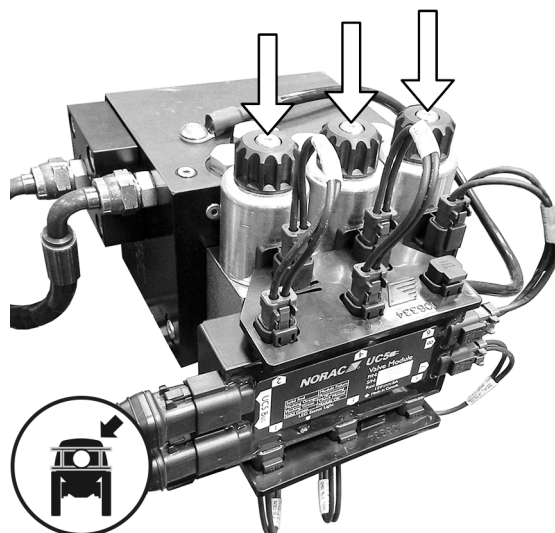

Hydraulic Motor for Liquid Pump (Optional)

HARDI requires that the tractor prioritize the oil flow to the hydraulic motor above the oil supply to other hydraulic functions on the sprayer.

HARDI also requires that the tractor provide sufficient oil flow to all functions on the sprayer.



NOTE! This oil motor is an alternative to the transmission shaft (PTO) connected between the tractor and sprayer.

This oil motor is mounted in front of the pump, and two hydraulic hoses are connected directly to the tractor outlets.

When the correct oil flow is applied from the tractor, the oil motor drives the pump at a speed of 540 RPM.

If the oil flow from the tractor is too high, flow valves connected to the hydraulic hoses automatically reduces the oil flow to match 540 RPM for the pump. This function is mostly used at start-up, where the oil flow is adjusted.

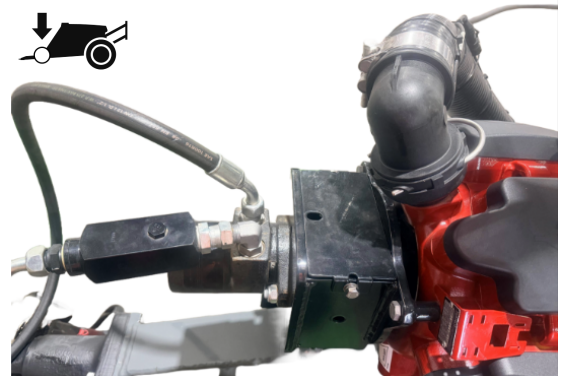
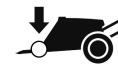

Oil Flow Requirements

The table shows required oil flow from the tractor, when the hydraulic motor for the liquid pump used in combination with other hydraulic-driven sprayer equipment.

Hydraulic Motor at 540 RPM	AutoHeight	Required Tractor Supply
36 L/min	Not fitted	36 L/min
36 L/min	30 L/min	66 L/min



NOTE! Running the hydraulic motor for liquid pump at lower RPM uses less oil than 36 L/min.

3 - Technical Description

Equipment

Operating the Grip (Optional)

The buttons on the grip in the tractor controls the following sprayer functions in the field:

- A. Status light for power ON/OFF.
The light will be blinking when the system is ON.
- B. Boom tilt up/down - left boom side.
- C. Thumbstick - not used.
- D. Boom slant to left - the left boom side down.
- E. Boom height down.
- F. Main ON/OFF for spraying.
- G. Boom slant to right - the right boom side down.
- H. Boom tilt up/down - right boom side.
- I. Boom height up.
- J. Distribution valves ON/OFF.
The switch is in up position: OFF.
The switch is in down position: ON.
- K. Not used.

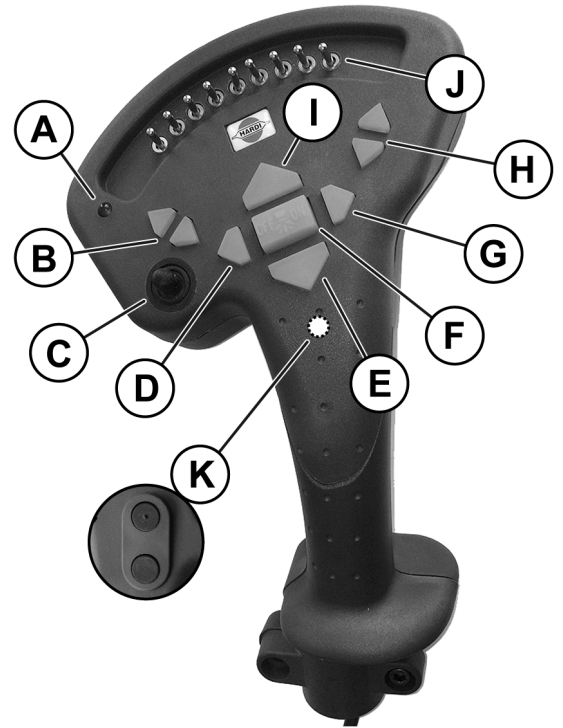

SetBox Controls (Optional)

	Power ON/OFF/status, LED light. The light must be ON.
	Automatic spray pressure regulation. The regulation valve controls the main spray pressure. This is default selection when the controller is powered ON, and it should remain here during normal spraying.
	Manual spray pressure regulation. During normal spraying, these regulations should not be used, as the regulation valve does this automatically.
	The IntelliComfortTrack function is used, when making turns in the field, ensuring: <ul style="list-style-type: none"> - a small turning radius. - a better stability when turning. - that the spray boom is perpendicular to the crop rows. Press "auto" for automatic adjustment of the sprayer. Press left or right arrow key to manually adjust the sprayer tracking.
	Optional function, A or B. If extra equipment is fitted, it can be controlled from here.

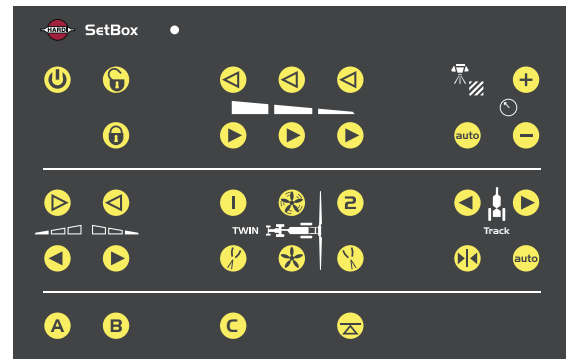

3 - Technical Description

Drawbars

All drawbars are fastened to the underside of the sprayer near the rear axle with 6 bolts secured by lock nuts. Furthermore the drawbar is supported by 2 bolts secured with lock nuts located in the area below the platform.

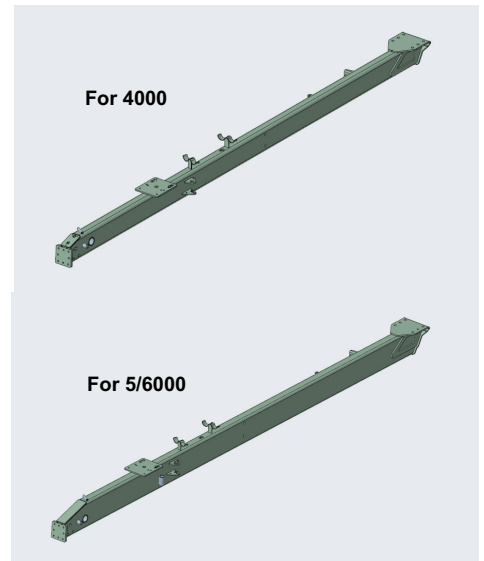

Following drawbar couplings are available:

Drawbar	Hitch Type	Hitch Attachment
A	Ball coupling Ø80	Bolted on drawbar
B	Pulling eye Ø50, swivel	Bolted on drawbar



Nozzle Pressure Gauge

The nozzle pressure gauge is integrated in to the top of the platform. This pressure gauge measures the working pressure in the boom tubes as close to the spray nozzles as possible.

The outputs stated on the nozzle charts are always based on the pressure measured at the nozzle. When both calibrating and spraying, the pressure must be adjusted according to the readings of this pressure gauge.



3 - Technical Description

SafetyLocker

This locker is integrated to the front left hand of the platform. The SafetyLocker is for storage of safety gear such as non-contaminated protective gear, soap for hand washing etc.

The locker is split in two compartments for the separation of clean clothes and contaminated equipment.



WARNING! Although this locker is meant for the storing of non-contaminated items, it must never be used for the storing of food, beverages or other items meant for human consumption.

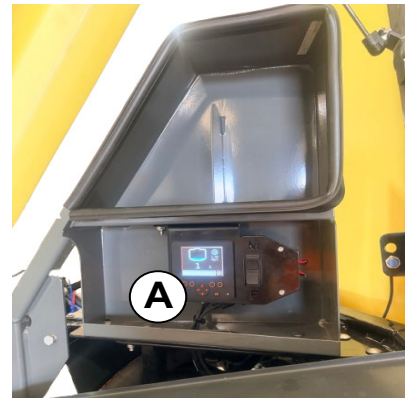

Filling Systems

Optional Filling systems and equipment

1. Filtered Fill system (Filtered -External Pump)
2. Hydraulic Filtered Fill (with high capacity Banjo Pump) (optional)

Filtered Fill

The Filtered Fill system allows the operator to fill the sprayer from an external water source using an auxiliary pump. The system includes a high capacity filter. The operator can also control the speed at which filling takes place by adjusting the quick fill ball valve on the sprayer.

By using the valve switch (B), the Filtered Fill system can be used to fill either "Main Tank" or "Rinse Tank".



WARNING! If a high capacity pump is used open the tank lid before filling, be prepared to quickly turn of the pump and valve when the tank is fill, otherwise there is a risk of overfilling causing structural damage to the tank.



ATTENTION! The Filtered Fill system should only be filled with clean water.

Cam Lock coupling sizes:

4000, 5000 and 6000 Litre models.....2 or 3 inch

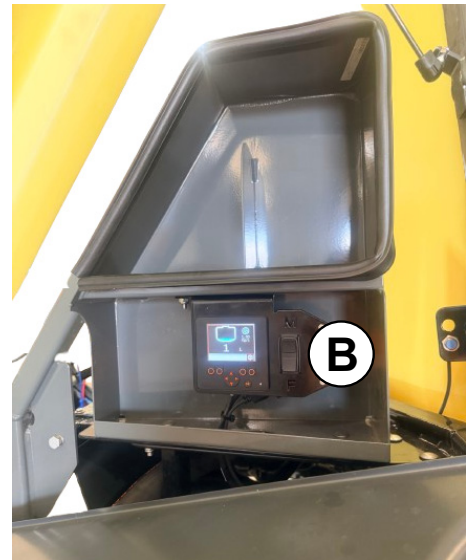

3 - Technical Description

Hydraulic Filtered Fill (Optional)

The Banjo Fast Fill system employs a high capacity centrifugal pump (P) driven by a hydraulic drive motor (M). The motor is powered by the tractor's auxiliary hydraulic system and is protected from over speeding by a hydraulic relief valve.

The operator can also control the flow rate by means of a speed control valve (V) mounted on a panel on the right hand side of the machine.



By using the valve switch (B), the "Banjo Fast Fill" system can be used to fill either "Main Tank" or "Rinse Tank".



General info

Before Putting the Sprayer into Operation

Although the sprayer has been supplied with a strong and protective surface treatment on steel parts, bolts etc. in the factory, it is recommended to apply a film of anti-corrosion oil (e.g. CASTROL RUSTILO or SHELL ENSIS FLUID) on all metal parts in order to avoid chemicals and fertilizers discoloring the paint or surface-treated parts.



NOTE! Fluids with high acidity are not recommended.



ATTENTION! This treatment should be carried out whenever the protective layer wears off.

If this is done before the sprayer is put into operation for the first time, it will always be easy to clean the sprayer and keep the paint or surface-treated parts clean for many years. This treatment should be carried out every time the protection film is washed off.

Jack Stand

The jack stand is stored in the bracket on the sprayer's right side when the sprayer is attached to the tractor.

To Use the Jack Stand

1. Lift the leg off the storage bracket.
2. The jack stand can then be mounted on the drawbar on both sides as preferred (for high hitch, left side only).
3. Secure with the linchpin.

To Remove the Jack Stand

1. Lift the leg.
2. Remove the linchpin and pull out the jack stand.
3. Secure the leg at the storage bracket with the linchpin.

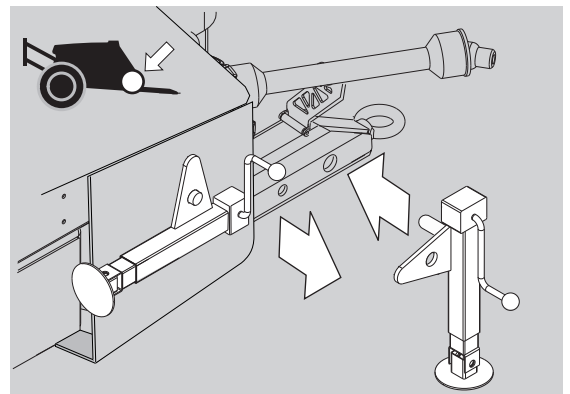

4 - Sprayer Setup

Jack Up the Sprayer

When the sprayer needs wheel mounting or changing of wheels, wheel bearings or brakes, jack up the sprayer under the axle as shown on the example picture.



DANGER! Be sure to place sprayer at level and firm ground to prevent the sprayer from falling off the jack.



DANGER! The tractor should be in park with the hand brake engaged and the key removed.



DANGER! No personnel should position themselves under the sprayer when it is only supported by a jack. Ensure that axle stands are in place before personnel are allowed under the machine.

For your safety:

- Use chocks at the opposite wheel to prevent rolling.
- Connect the sprayer's drawbar to a tractor to help balance the sprayer on the jack.
- Place strong support stands below the wheel axle, once it is jacked up. The jack alone is only for lifting and lowering the sprayer.

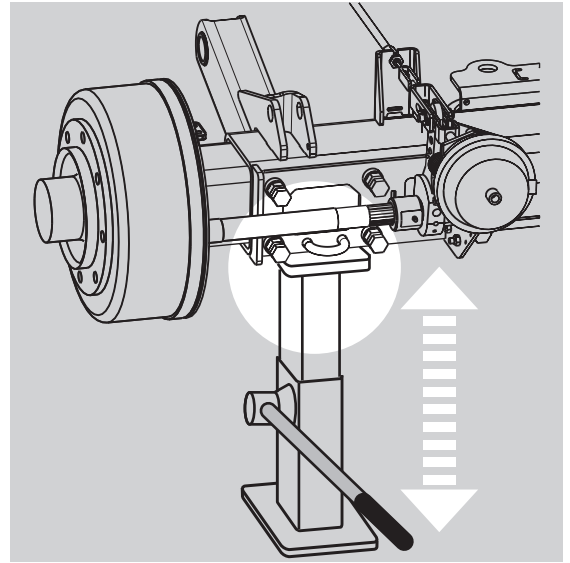

ParaLift Lock Brackets

With the spray boom folded in transport position, the ParaLift is in locked position. This is to prevent accidental movements of the boom while driving on the road.

Description of the Lock Mechanism for DDZ

When the boom is fully folded and the hydraulic cylinder (A) for the ParaLift fully extends to raise the boom into transport position, a lock bracket (B) automatically lowers onto the extended piston rod by means of another hydraulic cylinder (C).

The lock bracket will now prevent the piston rod from retracting unintentionally during road transport, if the hydraulic pressure drops. The lock bracket helps to ensure a safe transport position of the boom.



WARNING! During road transport, it is important that the lock bracket is in the lock position. If not, it could cause a dangerous situation, if the hydraulic pressure drops. Risk of the boom falling out of the transport brackets, resulting in damage to the wheel mudguards and further damage to the sprayer. The extent of the damage depends on the sprayer size and boom size; however, this damage is depending on other components failing as well.

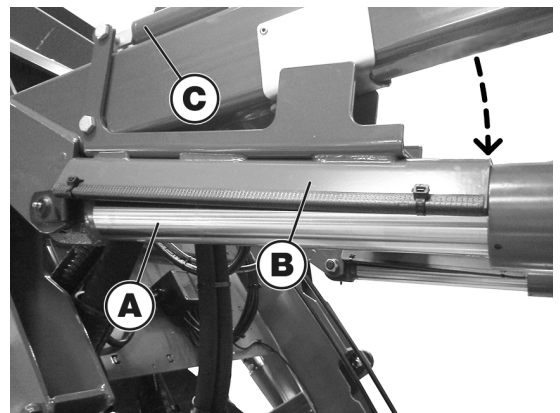

Service Situation



DANGER! In a service situation, it is very important that the lock bracket (B) is in the lock position. If the hydraulic pressure drops when standing below the ParaLift, it could cause a dangerous situation from a quickly lowered ParaLift.



DANGER! Risk of squeezing and being trapped. Risk of fatal accidents.

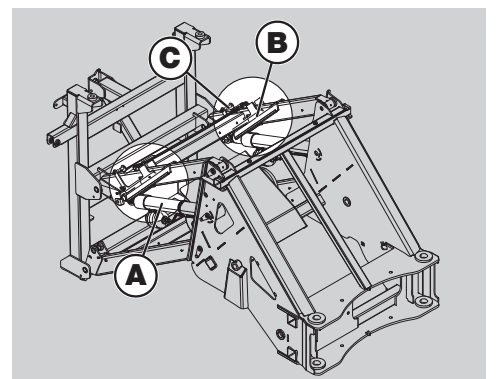

Tractor Requirements and Suitability

Tractor Selection

One or more tractors suitable for the task are selected and tested with the sprayer. The HARDI dealer will usually assist with this testing.

The owner of the sprayer must keep a document showing which tractors may be used for driving the sprayer. This document must be available to the operator of the sprayer.

4 - Sprayer Setup

Tractor Requirements

Main Pump

Min. / Max. operating power (kW): See type sign for liquid pump.

The type sign is located on the front side of the pump facing towards the tractor.

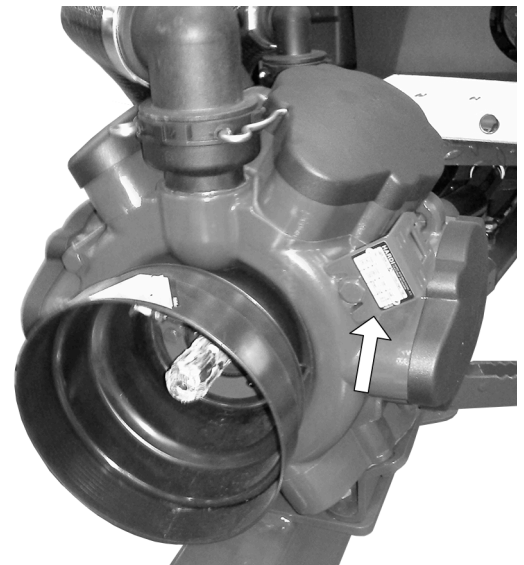

Hydraulic System

The hydraulic system requires:

- One double-acting outlet for the electro-hydraulic operation of the boom functions.



NOTE! The hydraulic hoses are marked with arrows to indicate the direction of oil flow.



ATTENTION! The hydraulic system requires an oil flow between 25 and 130 l/min and a minimum pressure of 180 bar.

Max. operating temperature	80 °C
Max. operating pressure from the tractor	210 bar
Min. operating pressure from the tractor	180 bar
Max. flow from tractor	120 l/Min
Min. flow from tractor @ 200 bar	15 - 80 l/Min*
Max. oil filter rating	10 µm

* Depending on scope of supply.



WARNING! All hoses MUST be connected. Ensure quick connect couplers are completely clean before connecting. Failure to do so will cause premature wear to the hydraulic system.



DANGER! If one or more the values are exceeded, this may cause damages and sudden leaks on the sprayer. Risk of injuries and fatal accidents.

Hydraulic Oil

Oil from the tractor to the sprayer must have been filtered according to ISO 4406 20/14 as a minimum. Particles bigger than 25 micron in size must be filtered from the oil (Filtration quotient β_{25-75} , ISO 4572-81 Multipass test).

- Follow the tractor oil change schedule as directed.
- Choose hydraulic oil with anti-foam and anti-oxidant additives.

Be especially cautious where the tractor transmission oil is also used for the sprayer hydraulics. Consult the tractor dealer if in doubt.

Type	Hydraulic oil with anti-foam and antioxidant additives.
Purity	ISO 4406 20/14. Filtration quotient β_{25-75} , ISO 4572-81.
Multipass test	25 micron absolute.
Viscosity	Minimum: 10 mm ² /s (cSt).
	Maximum: 100 mm ² /s (cSt).
	At normal operation: 15 - 35 mm ² /s (cSt).

Hydraulic Brakes

Max. hydraulic oil pressure	155 bar
Min. hydraulic oil pressure	145 bar
Max. hydraulic oil flow	30 litres/min
Min. hydraulic oil flow	10 litres/min



ATTENTION! The hydraulic circuit for the brakes is different from the general hydraulic circuit.

Voltage

The sprayer is designed for the following voltage only:

Voltage	12 V DC.
Tolerance for voltage	-1.5 V / +3.0 V
Current from tractor	40 A peak
Blade fuses on the sprayer	25 A*

*The blade fuses usually allow up to 50 A for a few seconds before blowing.



DANGER! If the tolerances for voltage are exceeded, the electrical system can fail. Risk of fire. Risk of defect or malfunctioning components.

Power Consumption

Recommended tractor engine output are as follows.

Main Tank Volume (litres)	Output (hp)	Output (kW)
4000	115	85
5000	130	96
6000	145	107

4 - Sprayer Setup

Transmission Shaft

Operator Safety

1. Always read the manufacturer's operator's manual before applying any changes to the transmission shaft!
2. Always STOP THE ENGINE and remove the ignition key, before carrying out maintenance or repairs to the transmission shaft or implement.
3. Always STOP THE ENGINE before attaching the transmission shaft to the tractor power take-off (PTO) - most tractor PTO shafts can be rotated by hand to facilitate spline alignment, when the engine is stopped.
4. When attaching the shaft, make sure that the snap lock is FULLY ENGAGED - push and pull the shaft until it locks.
5. Always keep the protection guards and chains intact and make sure that it covers all rotating parts, including CV-joints at each end of the shaft. Do NOT! use without protection guard.
6. Do NOT! touch or stand on the transmission shaft, when it is rotating - keep your safety distance at 1.5 meter. NEVER cross over a rotating PTO shaft to reach the other side of the sprayer.
7. Prevent protection guards from rotating by attaching the chains allowing sufficient slack for turns.
8. Make sure that protection guards around the tractor PTO and the implement shaft are intact.

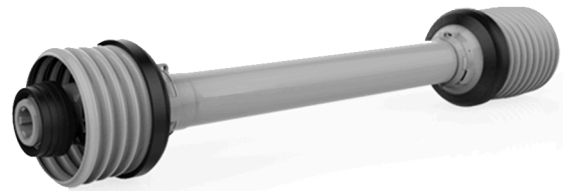
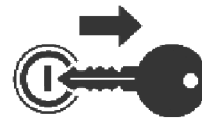

DANGER! A ROTATING TRANSMISSION SHAFT WITHOUT PROTECTION GUARDS IS FATAL!

PTO Installation

First installation of the transmission shaft is done in the following way:

1. Attach the sprayer to the tractor and set the sprayer height in the position with the shortest distance between the tractor and the sprayer pump PTO shafts.
2. Stop the engine and remove the ignition key.
3. If the transmission shaft needs to be shortened, pull the shaft apart. Fit the two shaft parts to the tractor and the sprayer pump and measure how much the shaft needs to be shortened. Also mark the protection guards with the same length to be shortened.



WARNING! Only shorten the shaft if it is absolutely necessary!

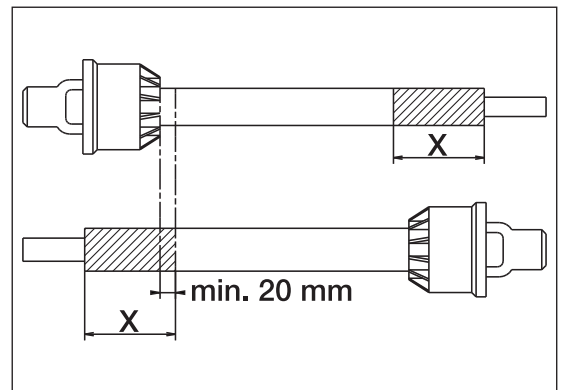

When cut, the shaft must always have minimum overlap (A) of 1/2 of the shaft length.

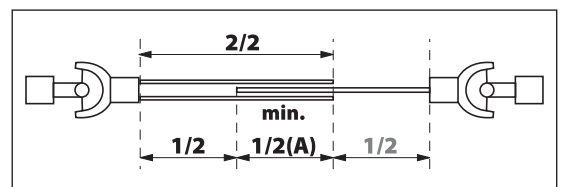

The recommended overlap (A) is 2/3 of the shaft length.

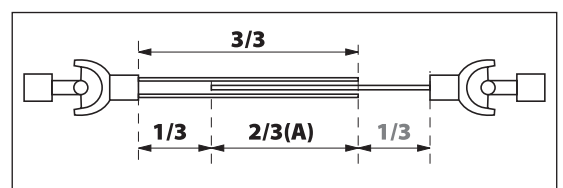

Mechanical Connections

Fixed Drawbars

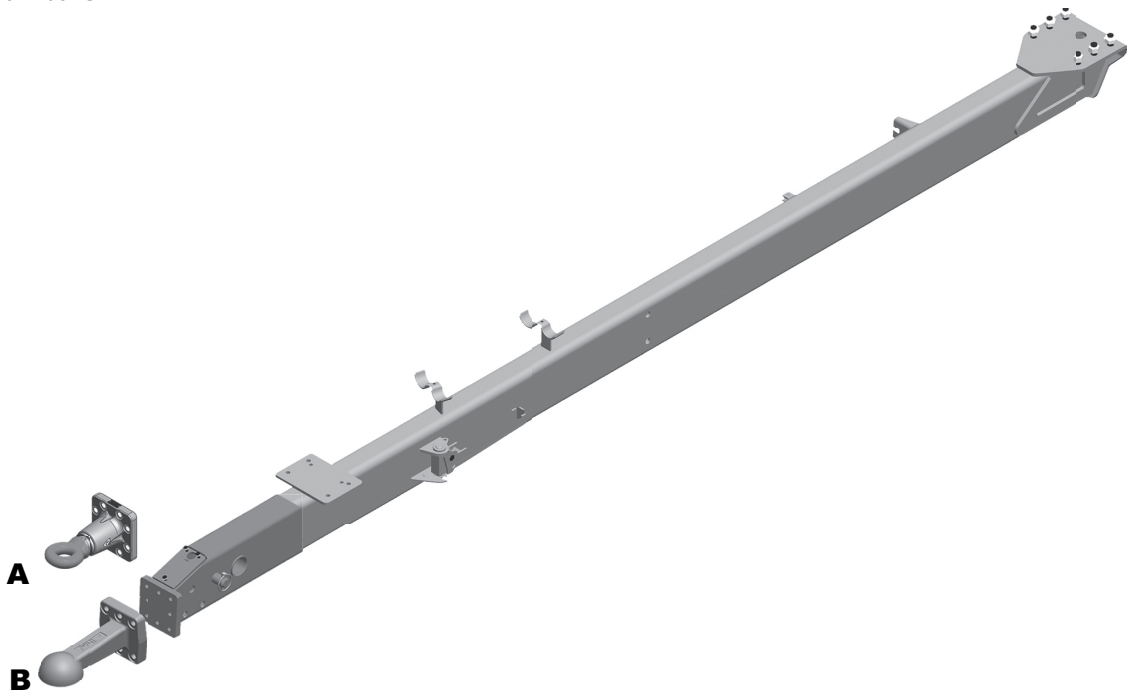

Hose Rack

To prevent hoses and wiring from being damaged by the tractor wheels or the PTO shaft, all hoses, cables and wires are held by the hose package support fitted to the sprayer platform.



ATTENTION! A sprayer with steering requires more slack in the cables. Make sure that the hoses and cables are long enough in tight turns, when fully steered.



ATTENTION! Hydraulic hoses are provided with plastic covers. It is recommended to fit these when storing the sprayer.



ATTENTION! Electrical connections should not be left exposed. If storing the sprayer outside, it is recommended to cover the connections and then clean them before use.

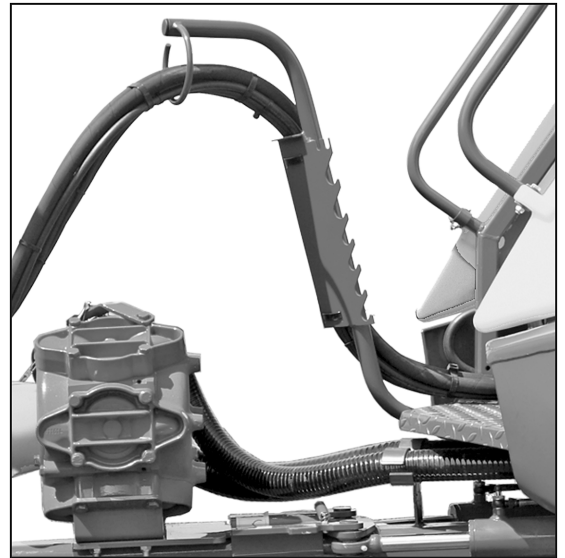

4 - Sprayer Setup

Hydraulic Systems

General Info

Ensure that the snap couplers are clean before connection! Failure to do so will cause premature wear to the hydraulic system.

After having operated the boom, and the system has been filled with oil, check the tractor's hydraulic oil level, and top up if necessary.



DANGER! Test of the hydraulic system should be done very cautiously. There may be air trapped in the system which can cause violent movements of the boom.



DANGER! Hydraulic leaks: Never use your fingers to locate a leakage in any part of the hydraulic system. Due to high pressure, hydraulic oil may penetrate the skin.

Connecting the hydraulics

Make sure the hydraulic quick couplings are clean and dry taking care to connect the correct hoses to "Pressure" and "Tank" (the hoses are clearly marked for positive identification). The size and number of hydraulic hoses to connect depends on the optional equipment fitted to the sprayer. To assist in identifying the right hoses they have been tagged with color coded "Zip-ties."

Function	Activation	Operation	Hose size	Tag colour	Hook up	
					A	B
Boom Hydraulics						
DDZ	ISOBUS	All	3/4"	Green	Pressure	Tank (Return)
Options						
364 Pump Hydraulic Drive	Tractor Remote Control	Pump drive	1/2"	Red	Pressure	Tank (Return)
Banjo Filling Pump	Tractor Remote Control	Pump drive	1/2"	White	Pressure	Tank (Return)
Ace Centrifugal Pump	Tractor Remote Control	Pump drive	1/2"	Red	Pressure	Tank (Return)
Clisby Air Compressor	Tractor Remote Control	Pump drive	1/2"	Blue	Pressure	Tank (Return)

Requirements for Tractor

The hydraulic system requires:

- One double-acting outlet for the electro-hydraulic operation of the boom functions.
- One double-acting outlet for the operation of the hydraulic pump drive (alternative to a PTO shaft).
- One double-acting outlet for the operation of Hydraulic Filtered Fill with Banjo Pump (optional).



ATTENTION! The hydraulic hoses are marked with arrows to indicate the direction of oil flow.

Other Information

- The system has a built-in flow regulator that maintains constant speed on hydraulic movements.
- Oil flow between 50 and 80 l/min at a pressure of 200 bar.
- Minimum oil pressure is 180 bar to obtain correct operation. Maximum permissible oil pressure is 210 bar.
- Return flow restriction of the connected tractor must be maximum 10 bar. If this pressure is higher, the anti-yaw system will not work properly.
- For Load Sensing systems, an oil flow of approximately 5 l/min at 25 bar is supplied by the sprayer hydraulics. If a higher flow is required, a different orifice must be installed between the "open centre" hydraulic block and the load sensing (LS) hydraulic line - see "Open and Closed Centre Hydraulics" on page 84 for more information.

Adjusting Oil Flow for Hydraulic motor

For a liquid pump driven by a hydraulic motor to run stable at the set RPM, independently of other hydraulic sprayer functions used, it is necessary to prioritize and adjust the oil flow from the tractor to the hydraulic motor.

Tractors can perform this oil flow priority in two ways:

- Dedicated oil flow priority.
This is an optional extra on many tractors. Older tractors have a mechanical lever or a dial to adjust this priority. Tractors with a terminal has a menu to adjust priority of flow.
- Flow control for each tractor valve outlet.
Many newer tractors have it as standard. Older tractors usually have a mechanical lever or dial to adjust each oil flow. Tractors with a terminal has a menu to adjust the flow for each function.

Both the dedicated oil flow priority and flow control for each tractor valve outlet will work. The difference is that a dedicated oil flow priority is independent of the tractor motor RPM. Whereas the flow control for each tractor valve outlet requires a set tractor motor RPM while spraying. Therefore, it is necessary to do the flow control adjustment at this RPM.

Oil Flow Adjustment

In the following parts, three methods described for oil flow adjustment, depending on the specific tractor used:

- Tractors with dedicated oil flow priority.
Refer to “Tractors with Dedicated Oil Flow Priority” on page 82.
- Tractors with flow control for each tractor outlet.
Refer to “Open and Closed Centre Hydraulics” on page 84.
- Tractors without flow control and priority.
Refer to “Open and Closed Centre Hydraulics” on page 84.

General for the Hydraulic Driven Pump

- When increasing the spray pressure from 1 bar to 4 bar the pump RPM decreases from 540 RPM to around 535 RPM. This is normal and acceptable behaviour.
- The hydraulic motor for the liquid pump consumes a significant oil flow, around 36 l/min. This might affect the performance of the other hydraulic functions on the sprayer, such as AutoHeight. Solve this by increasing the tractor engine RPM. Doing so, adjustment of priority function or the flow control function is required again.
- The speed-limiter hydraulic valve fitted on the hydraulic motor only protects the liquid pump against over-speeding. This hydraulic valve do not perform RPM speed control, the tractor valves do this. Over-speeding limit is around 580 to 600 RPM.

Inaccurate Oil Flow

In general, an inaccurate oil flow from the tractor will result the following:

Oil flow too high	Reduces the capacity of the liquid pump caused by a pressure drop at the flow valve. Wasted energy, as the built-in flow valve for safety adjusted to 38 l/min.
Oil flow too low	The pump speed decreases, causing the suction from the TurboFiller to be slow, when filling chemicals.

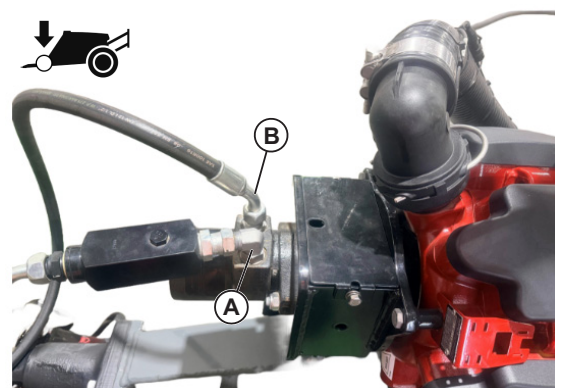

The hoses are factory fitted in the ports on the motor to match the standard fitting for the direction of the pump rotation. If reversing the hoses, the motor will rotate the opposite way. The pump performance will however remain unchanged.



4 - Sprayer Setup

Tractors with Dedicated Oil Flow Priority

The oil flow from the tractor is set for a pump speed of e.g. 400 RPM or at a maximum 540 RPM.

1. Connect the hydraulic motor for the liquid pump to the tractor outlet.
2. Make sure that there is liquid in the MainTank.
3. Set the valve positions for  and for .
4. Gently apply hydraulic oil flow from the tractor.
 - If the tractor has a setting option, set the oil flow to 36 l/min.
 - If no setting available, continue with step 4.
5. Using the priority function, increase the oil flow while monitoring the pump speed-reading. If the pump is fitted with a speed sensor, then monitor [menu 2.1.2.17] in the controller display.



ATTENTION! For other tractor outlets without priority function, set the flow control to 100% to direct all remaining oil flow to the other sprayer hydraulic functions.



6. At the same time, adjust the spray pressure to 3 bar.
7. When the pump speed reaches e.g. 400 RPM or at a maximum 540 RPM at 3 bar spray pressure, the oil flow from the tractor is correctly set at 36 l/min. Keep this setting for the tractor.
8. Make a note of the priority setting, so it is easy to connect and setup the sprayer next time.



ATTENTION! Do this adjustment every time coupling the sprayer to the tractor, or if previously using the tractor outlets for other hydraulic functions.

Tractors with Flow Control for each Tractor Outlet

Procedure for adjusting the hydraulic oil flow from the tractor to match the desired pump speed RPM of e.g. 400 RPM or a maximum of 540 RPM:

1. Connect the hydraulic motor for the liquid pump to the first tractor outlet (typically outlet A or outlet 1).
 2. Connect other hydraulic functions to the second tractor outlet (typically outlet B or outlet 2).
 3. Adjust tractor engine to the desired RPM used while spraying.
 4. Make sure that there is liquid in the MainTank.
 5. Set the valve positions for  and for .
 6. Close hydraulic valves used for supplying other hydraulic functions on the sprayer.
 7. Gently apply hydraulic oil flow from the tractor.
 8. Using the flow control function, increase the oil flow while monitoring the pump speed-reading in [menu 2.1.2.17] on the controller display. Increase the oil flow until the pump reaches e.g. 400 RPM or a maximum of 540 RPM.
 9. Keep the hydraulic motor for the liquid pump running.
 10. Open the hydraulic valves used for supplying other hydraulic functions on the sprayer.
Note that the valve on the bypass block shall be set in the open centre position. Do not activate any sprayer hydraulic function, to ensure a low hydraulic circulation pressure.
 11. Using the flow control function, increase the hydraulic oil flow to the other hydraulic functions on the sprayer (outlet B or outlet 2) until the pump speed RPM drops.
 12. If the opening a hydraulic valve causes the pump RPM to decrease:
 - A. Use the flow control function to decrease the hydraulic oil flow to the other hydraulic functions on the sprayer (outlet B or outlet 2) until the pump speed RPM reaches e.g. 400 RPM or a maximum of 540 RPM.
 - B. Using the flow control function, decrease the oil flow 2% (e.g. from 64% to 62%) to obtain a safety margin for the hydraulic motor.
3. Make a note of the flow control setting, so it is easy to connect and setup the sprayer next time.



NOTE! In the case that the farmer uses 400 RPM for spraying and 540 RPM for filling, then the flow must be changed each time in the tractor terminal.

Tractors without Flow Control and Priority

Tractors without flow control and without priority requires a special priority valve fitted to the sprayer, instead of the HARDI-supplied speed-limiter valve.

This special priority valve will control and keep the hydraulic motor for the liquid pump at constant RPM, and will supply other hydraulic functions on the sprayer with the remaining oil flow.

This configuration does not allow stopping the water pump when operating the boom folding functions.

HARDI does not provide this special priority valve.

Test Procedure

1. Increase the spray pressure from 1 bar to 4 bar.
2. Check that the pump RPM does not decrease more than 5 RPM.
3. Turn down spray pressure to 1 bar.
4. Repeat the test by now increasing the spray pressure from 1 bar to 9 bar.
5. Check that the pump RPM does not decrease more than 15 RPM.
6. Set to normal spray pressure.
7. Operate AutoHeight while checking that the pump RPM does not decrease more than 1 RPM.

4 - Sprayer Setup

Open and Closed Centre Hydraulics

The hydraulic block is necessary, if the tractor uses open centre hydraulics and/or load sensing (LS). The hydraulic block is accessed from below the sprayer chassis.

The open/closed selector valves (1) and (2) are factory set for the use of open centre hydraulics. If closed centre hydraulics is used, then turn in valve (1) clockwise. Also, press valve (2) in and turn right to lock.

 **WARNING!** Always be sure to fully open or close the selection valves for open/closed centre hydraulics.

Connection to Tractor

Certain tractor models are able to use Load Sensing without connecting an external sensing line. However, if not possible to obtain an optimal sensing control pressure; connect an external sensing line to the tractor.

If Load Sensing (LS) is to be used, connect a hydraulic hose from the tractor LS port to the O-LS port (D) on this hydraulic block.

Connection size for port D is G1/4".

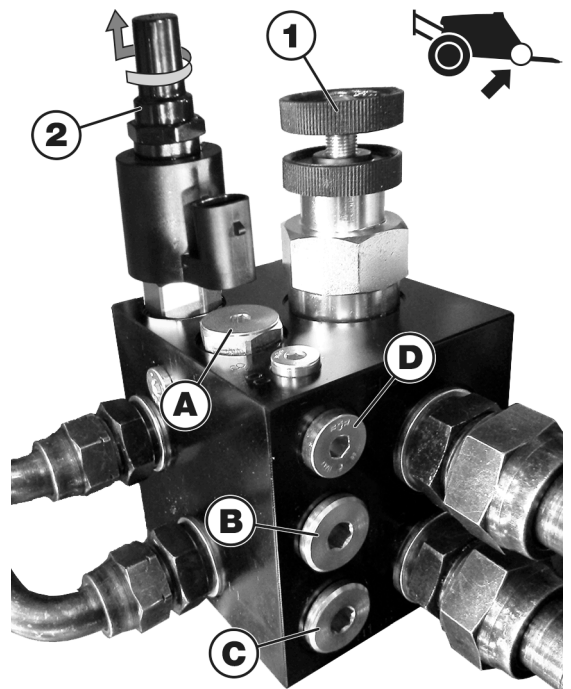

Load Sensing Setup

The restrictors inside the hydraulic block have different orifices depending on the oil flow returned to the tractors oil pump.

Plug	Orifice
A	Ø 0.8 mm (default setting)
B	Ø1.2 mm
C	Ø1.6 mm

1. Check the hydraulic flow by activating a hydraulic lever in the tractor. If the reaction time for the hydraulic function is relatively short, continue your work with this restrictor installed.
2. If the reaction time seems too long before the hydraulic function is enabled, switch the plug (A) with the spare plug (B) to allow more oil flow to pass through.
3. If the reaction time is still too long, switch the plug (A) with the plug (C).
4. Always fit the plug removed from port (A), in the port (B) or (C).

 **ATTENTION!** Ask your HARDI dealer for correct setup if in doubt.

Combinations of settings for the hydraulic block:

Application	Valve 1	Valve 2	Port A, B or C
Open centre	Out	Out	No change
Closed centre	In	In	No change
Load sensing (LS)	In	Out*	Change if needed

*If the tractor requires pressure relief, contact your tractor dealer for further advice.

 **WARNING!** It is essential that connectors on the sensing line are kept totally clean, so that impurities do not enter the pump. Impurities may cause damage to vital pump parts.

Before operating the hydraulics, the valve should be set according to the specific tractor model. If you are unsure of the type of hydraulic system in your tractor, please contact your tractor dealer.

 **NOTE!** A Load Sensing kit is available for connecting the hydraulic block to the tractor - ask for HARDI item no. 74193800.

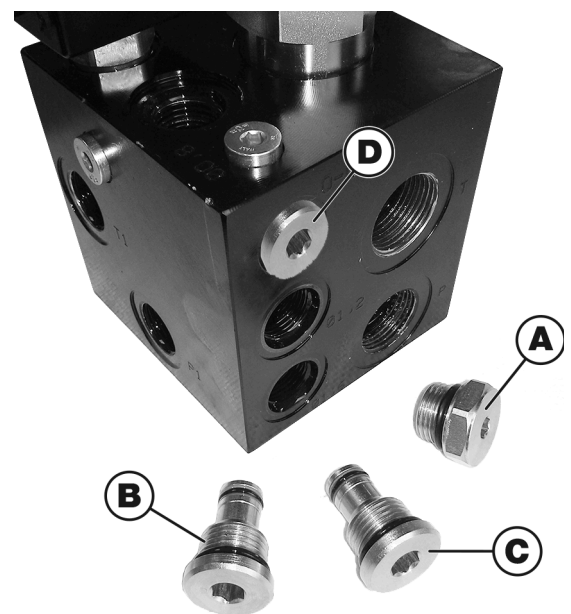

Adjustment of Boom Folding Speed

The main hydraulic block distributes hydraulic fluid for the boom controls.

The throttle valve (A) can adjust the folding speed of the boom.

Check the Folding Speed

- Unfold the boom.
- Fold the outer boom sections calmly into the transport position without crashing hard against the other boom sections.

The folding speed is set from factory. However, it may be adjusted before use of the sprayer if the operator finds it necessary.



ATTENTION! The throttle valve only needs slight adjustments to change the speed significantly.



ATTENTION! If the boom moves too fast:

- Risk of premature wear and tear.
- Risk of damaging the boom parts.

Factory Setting

The valve is screwed completely in and 1/2 turn back out.

To Decrease Folding Speed

1. Loosen the counter nut.
2. Screw the valve inwards.
3. Tighten the counter nut again.

To Increase Folding Speed

1. Loosen the counter nut.
2. Screw the valve outwards.
3. Tighten the counter nut again.



ATTENTION! The system must be de-pressurized during the adjustment.

Tools Needed

Size: 17 mm



Size: 5 mm

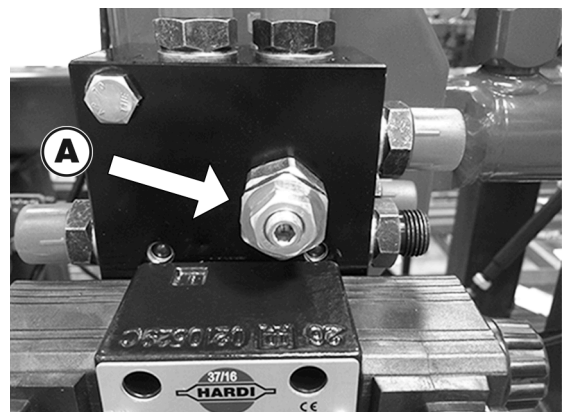
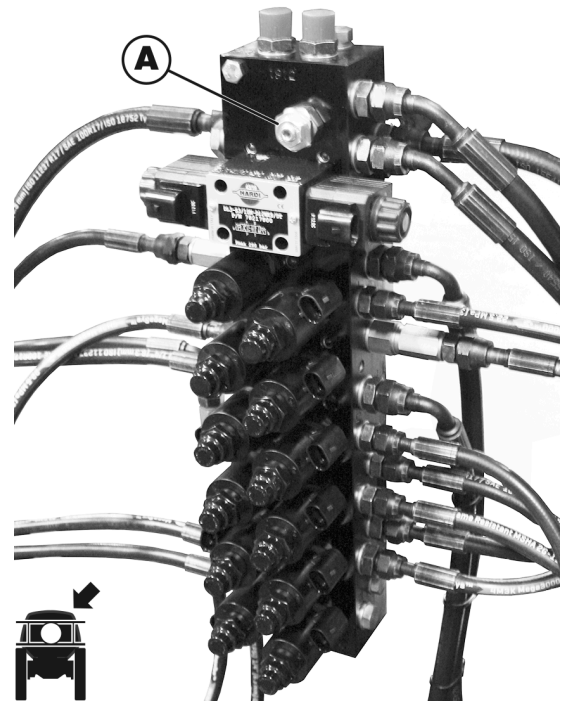

4 - Sprayer Setup

Adjustment of Pendulum Damping

After adjusting the boom suspension mechanically, it is possible to fine-tune the boom movements in the field if necessary. This is done by adjusting the damping control. It is located in the boom centre below the hydraulic cylinder.

Preparations

1. Park the sprayer and activate the tractor's handbrake.
2. Unfold the boom and adjust the boom height to approx. 1.5 meters above the ground.
3. Unlock the pendulum in the boom centre by pressing .
4. Warm the oil in the pendulum damper to working temperature, by using slant function several times.

Tools Necessary for Adjustment

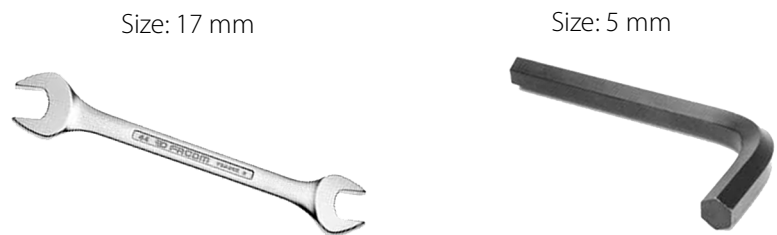

Adjustment

Change the hydraulic oil flow, by adjusting the valve:

5. Using a spanner, loosen the counter nut (A).
6. Using an Allen key (B), turn the throttle valve inwards until the stop.
7. Turn it 3 full turns outwards (= factory setting).
8. Now test the damping of the boom, as described.

 NOTE! After adjusting the boom suspension mechanically or electrically, always test the boom damping by hand and re-adjust if necessary.

9. Stand next to the boom tip. Ensure that there are no objects nearby or excessive wear on the boom, which can prevent a free vertical movement of the boom.

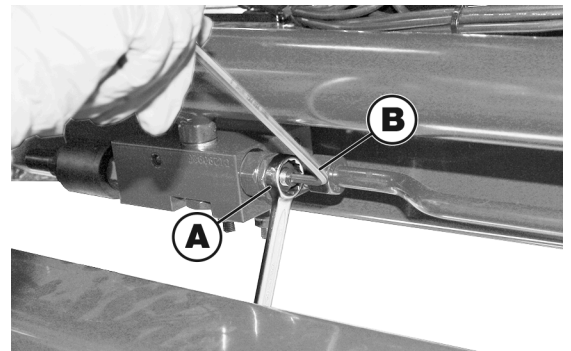

10. Note the boom height. Push the boom tip down to the ground.
11. Hold the boom steady for a moment and release it.
12. Check that the boom returns to its starting position as quickly as possible, with little or no overshoot.

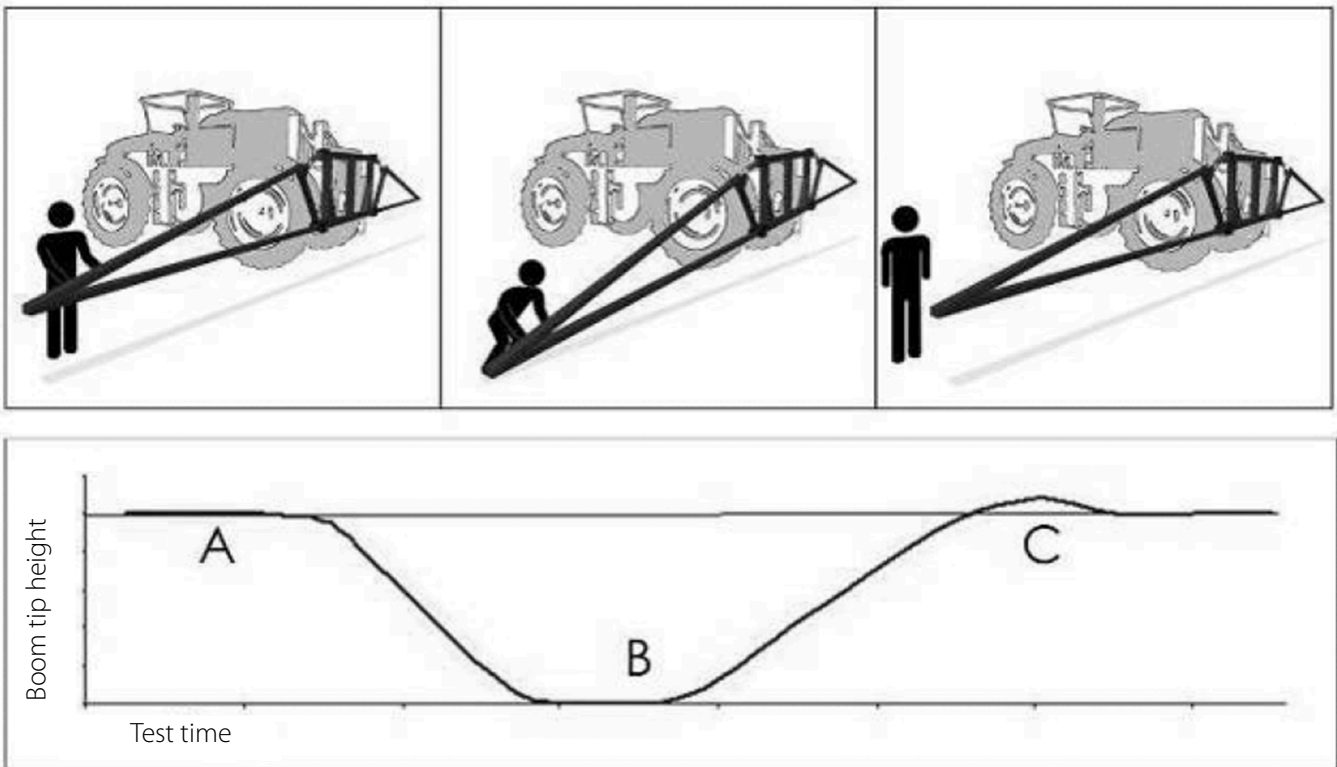

13. Adjust damping:
 - More boom damping: Turn the throttle valve inwards.
 - Less boom damping: Turn the throttle valve outwards.

i NOTE! The valve is very sensitive - only make minor adjustments before testing the boom damping.

14. Re-test the damping of the boom.

Correctly adjusted, the boom will react immediately and depending on the boom damping setting, the boom, to some extent, will follow the sprayer's wheel axle movements.
15. Re-adjust and test the damping of the boom, if necessary.
16. Once the boom damping is correctly adjusted, tighten the counter nut (A).

4 - Sprayer Setup

Electrical Connections

Road Safety Kit

If rear lights are installed, connect the plug for rear lights to the tractor's 7-pin socket and check the function of rear lights, stop lights, side lights and direction indicators on both sides before driving.

The wiring is in accordance with AS 4177.5-2004. See the chapter "Technical Specifications" in this Instruction Book.

 ATTENTION! Turn OFF all work lights when driving on public roads!

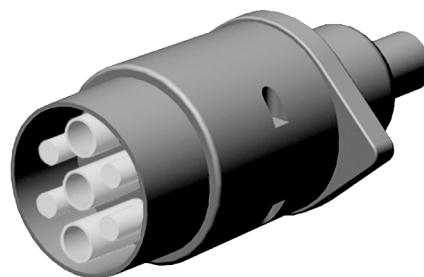

Speed Sensor for Sprayer

The speed sensor and speed ring is located at the inside of the sprayer's right wheel. The sensor is an inductive type that requires a metallic protrusion like the speed ring to pass by it to trigger a signal.

Adjustment

1. Assure that the speed ring fitted correctly to the wheel, so that the arrow (A) follows the rotation of the wheel in the forward driving direction.
2. Check that the black sensor (D) lines up in the middle of the air gaps in the speed ring when looking in vertical direction.

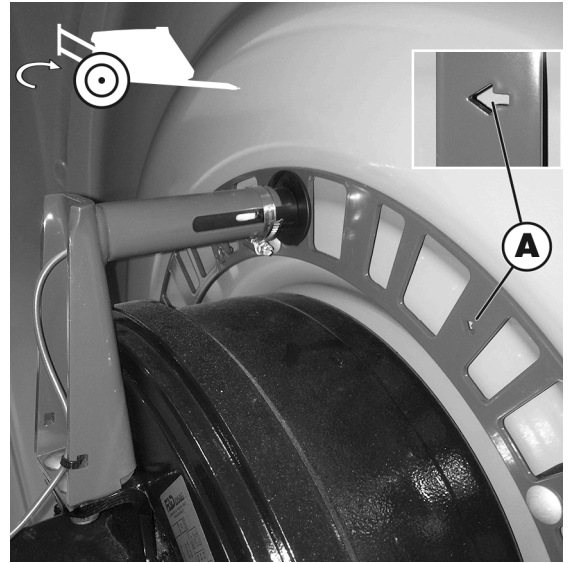

3. Adjustment of the air gap begins with the sensor directly opposite one of the bolts (E) holding the speed ring.
Loosen the clamp (C) to move the sensor (D) in or out of the red tube. Re-tighten the clamp when finished.
4. Adjust the air gap (B) between sensor and speed ring to 4 mm.
Use a feeler gauge or similar tool.

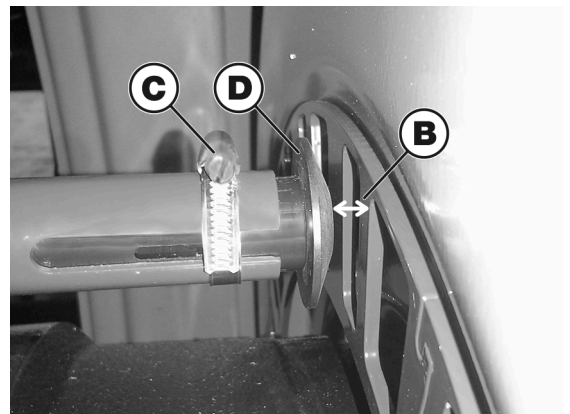

5. After adjustment, spin up the wheel.
The air gap variation must be less than ± 0.5 mm for the sensor to function correctly.
Check this at the entire circumference of the wheel.
6. Verify the speed on the controller.

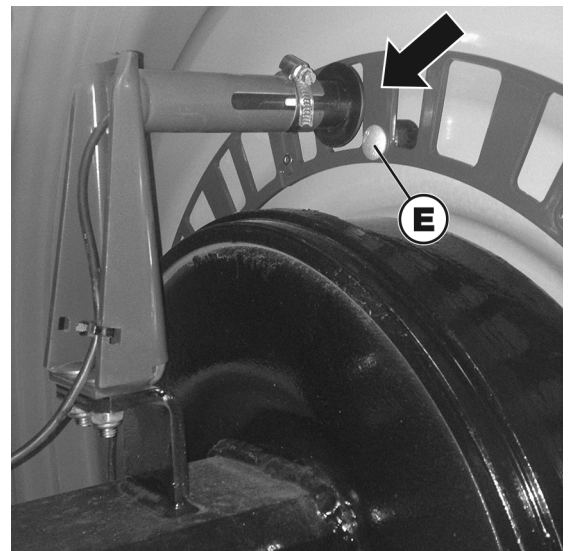

ATTENTION! Continuous flashing from the transducer indicates correct fitting when the wheel rotates.

4 - Sprayer Setup

Liquid System

Water Sensitive Paper

Use this type of paper to help find the best spray setup.

Some time spent in different types of crops with clean water in the tank and some water sensitive paper will create a valuable experience for the future work with your sprayer.

Test

The paper can be cut into smaller pieces (to simulate the target), then fixed with double-sided tape at relevant places in the crop.

Now spray with pure water and check the blue spots (droplets) on the paper. This way you can test different spraying techniques.

Water sensitive paper is available at your local HARDI dealer (ask for HARDI item no. 893211).

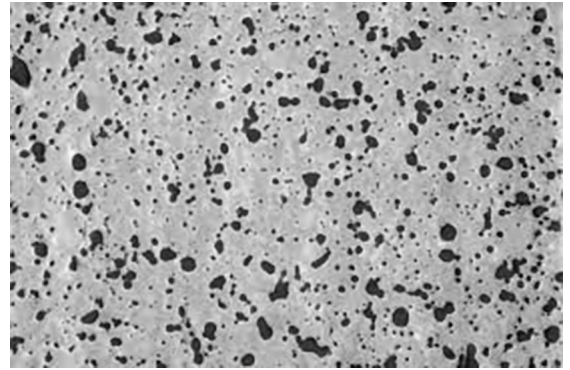

Track Width, Axles and Wheels

Turning the Wheel Rim

It is possible to alter the sprayer track width by turning the rims.

After turning the rim around in both sides of the sprayer, new track width can be read in the table below.

i NOTE! Some tyre sizes listed may not be available for your sprayer.

Rim Size	Wheel Bolts	Track Width Increases by
270/95 R38	8 pcs.	322 mm
270/95 R48	8 pcs.	322 mm
300/95 R46	8 pcs.	222 mm
300/95 R52	8 pcs.	222 mm
340/85 R48	8 pcs.	222 mm
380/85 R34	8 pcs.	330 mm
380/90 R46	8/10 pcs.	230 mm
420/85 R38	8 pcs.	222 mm
460/85 R38	8 pcs.	222 mm
520/85 R38	8 pcs.	222 mm
520/85 R42	10 pcs.	226 mm
520/85 R46	10 pcs.	230 mm
650/65 R42	10 pcs.	226 mm
900/50 R42	10 pcs.	230 mm

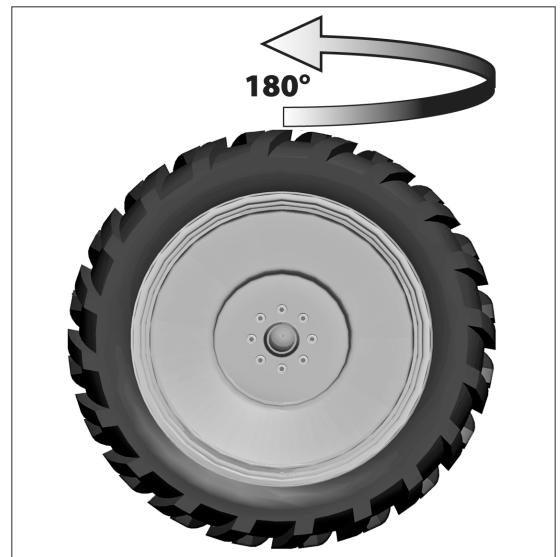

Altering the track width

The track width of the sprayer can be altered as follows.

Altering procedure

1. Measure the current track width (centre RH tyre to centre LH tyre). Each side must be extended or retracted half the desired alteration.
2. Attach the sprayer to tractor and engage tractor parking brake.
3. Place stop wedges in front of and behind RH wheel. Jack up LH wheel, support and secure sprayer body.
4. Loosen the conenut at the bolts (A) and the bolts (A) for LH wheel axle.
5. Extend or retract the axle.
6. Tighten the clamp bolts (A) to a torque of 640 Nm and lock the bolts with the conenuts.
7. Lower down the LH wheel.
8. Repeat the procedure on RH wheel.
9. Check if the distance from centre tyre to centre of rear frame is equal at RH and LH.
10. Re-tighten bolts and wheel bolts to specified torque after 8 hours of work.

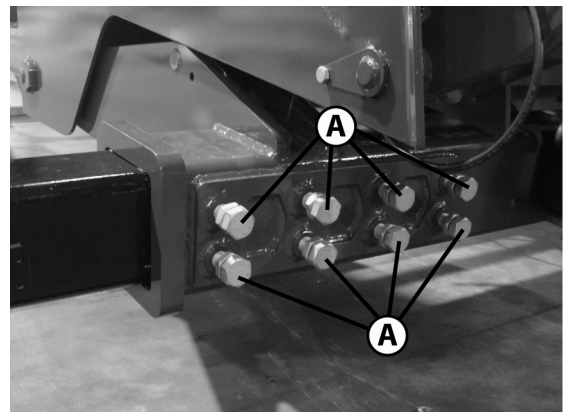

⚠ WARNING! Bolts must always be locked and must always have contact. Never widen the axle beyond the securing bolt locations (A).

⚠ ATTENTION! The wider the track width, the better the stability of the sprayer. HARDI recommends to work with widest possible track width.

4 - Sprayer Setup

Transport

Transport lock boom DDZ

The boom is mechanically held in transport position with paralift lock mechanisms that automatically engage when the first outer is closing. The folded channel-section locks are fixed to the top paralift arm and engage directly on the top of the paralift cylinders when lowered for transport. This means the boom is not supported by hydraulic oil pressure when in transport.



WARNING! Paralift locks should be checked before and after transport to ensure positive lock engagement.



WARNING! When the sprayer is being transported along rough road and is bounced over pot holes, in extreme cases there is a risk that the lock arms can disengage.



Counter Weight

To improve stability on articulated models, extra weight can be added by means of liquid-filled tyres.

The standard tyre valve is an universal air-water valve. The tyres may be filled with liquid to max. 75% of their total volume.



ATTENTION! Use only a suitable tyre coolant.

Filling the Tyres

1. Jack up the wheel and rotate wheel till the valve is positioned at "12 o'clock".
2. Remove the valve body and fill liquid, until it reaches the valve.
3. When surplus liquid is drained through the valve stem, fit the valve body again.
4. Adjust tyre pressure and lower the wheel.

Please refer to "Tyre Pressure" on page 205.

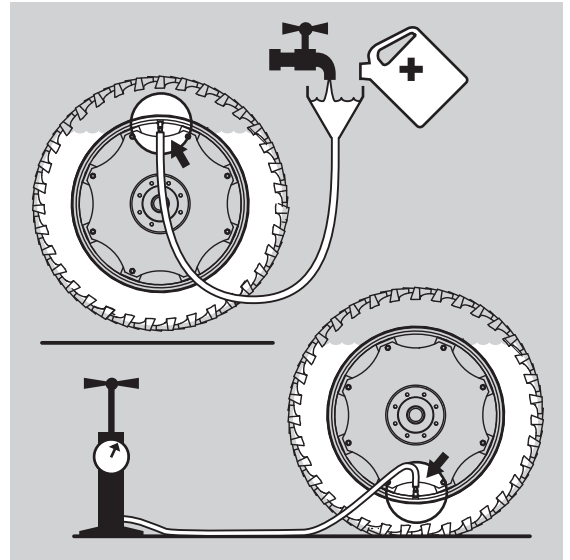

WARNING! The tyres must be liquid filled to max. 75 % of total tyre volume. Fill only the quantity. of liquid necessary to obtain sufficient stability of the sprayer.



ATTENTION! When filling the tyres, the valve should be positioned at 12 o'clock, and when adjusting the tyre pressure the valve should be positioned at 6 o'clock.

Emptying the Tyres

1. Rotate wheel until the valve is positioned at "6 o'clock".
2. Remove the valve body and lead the liquid away. Retain the liquid in an appropriate container.
3. To empty the tyre completely, the tyre is inflated and a thin drain tube is led to the bottom of the tyre. The air pressure will now empty the remaining liquid.
4. Remove the drain tube, fit the valve and inflate the tyre to specified pressure. Please refer to "Tyre Pressure" on page 205.

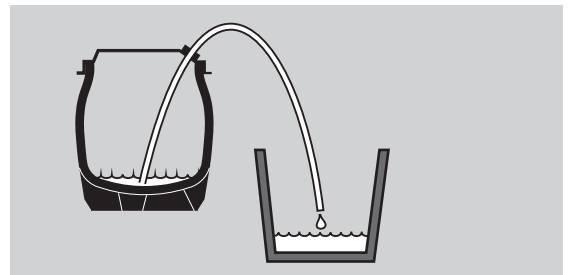

ATTENTION! Disposal of tyre coolant has to take place according to local legislation.

4 - Sprayer Setup

Operating the Spray Boom

Safety Info

Keep the spray boom in folded position while driving outside the field. Park the sprayer and tractor on level ground before using the folding/unfolding functions.

Failure to comply will damage the boom and cause dangerous situations to people and the surroundings.



DANGER! Before unfolding the boom, it is important to connect the sprayer to the tractor's hitch point to prevent overbalancing of the sprayer. Activate the tractor's handbrake.



DANGER! When folding or unfolding the boom, make sure that no persons or objects are within the operating area of the boom.



DANGER! Always follow the guidelines listed below when driving in areas with overhead power lines:

Keep from using the folding/unfolding functions in areas with overhead power lines. Unintended boom movements may cause contact with overhead power lines, causing a risk of fatal accidents.



ATTENTION! A label (HARDI item no. 978448) is supplied with the sprayer. You must place this label in the cabin, in a position visible from the operator's seat.

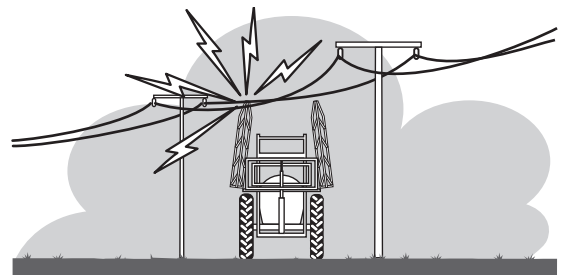

5 - Operation

Manoeuvring of the Boom (Z-versions)

Applicable for SmartCom controllers

Applicable for SmartCom controllers.



WARNING! The folding functions must only be operated, when the sprayer is stationary! Failure to do so will damage the boom.











ATTENTION! Only unfold and fold the boom on level ground.













ATTENTION! The boom can not be operated with the tractor's hydraulic levers.

With SmartCom Controller

Unfold the Boom

1. Press the button  to lift the boom clear of the transport brackets. This takes approximately 3 seconds.
2. The symbol  must be shown on the display.
If not, lock the pendulum by pressing  for 1 second.
3. Press the button  to unfold inner wings completely.
4. Press down-buttons  and  to tilt boom wings down to horizontal position.
5. Press the button  to unfold outer wings.
6. Press button (H) to lower the boom to the correct working height.
7. Unlock the pendulum by pressing  for 1 second.
The symbol  is now shown on the display.



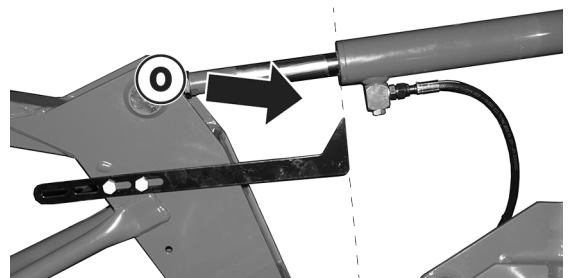

Fold the Boom

1. Press  to set a neutral slant angle (no slant).
2. Lock the pendulum by pressing  for 1 second.
The symbol  is now shown on the display.
3. Press button  to raise the boom to the highest possible position.
4. Press the button  to fold outer wings.
5. Press up-buttons  and  to tilt boom wings up until the arrow at the tilt cylinder flies with end of the tilt cylinder housing (O).
6. Press the button  to fold inner wings.
7. Press the button  to lower the boom, until it rests in the Paralift locks.
8. Press the down-buttons  and  to lower the left and right boom wings, until they rest in the transport brackets.





With Grip and SetBox (optional)

Unfold the Boom

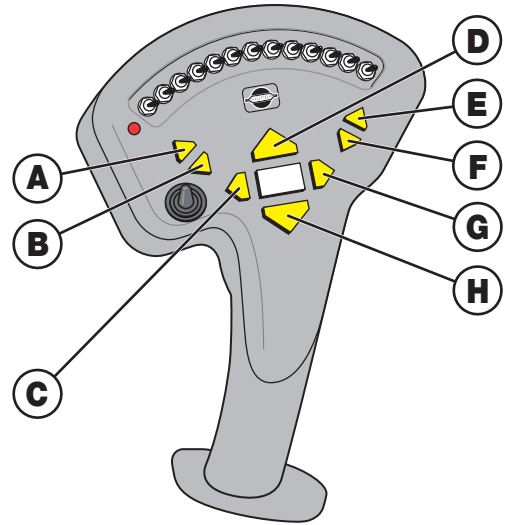
1. Press the button (D) to lift the boom clear of the transport brackets. This takes approximately 3 seconds.
2. The symbol  must be shown on the display. If not, lock the pendulum by pressing  for 1 second.
3. Press the button (L) to unfold inner wings completely.
4. Press down-buttons (B) and (F) to tilt boom wings down to horizontal position.
5. Press the button (M) to unfold 1st outer wings.
6. 3-fold boom only: Press the button (N) to unfold 2nd outer wings.
7. Press button (H) to lower the boom to the correct working height.
8. Unlock the pendulum by pressing  for 1 second. The symbol  is now shown on the display.



Fold the Boom

1. Press  to set a neutral slant angle (no slant).
2. Lock the pendulum by pressing  for 1 second. The symbol  is now shown on the display.
3. Press button (D) to raise the boom to the highest possible position.
4. 3-fold boom only: Press the button (K) to fold 2nd outer wings.
5. Press the button (J) to fold 1st outer wings.
6. Press up-buttons (A) and (E) to tilt boom wings up until the arrow at the tilt cylinder flies with end of the tilt cylinder housing (O).
7. Press the button (I) to fold inner wings.
8. Press the button (H) to lower the boom, until it rests in the ParaLift locks.
9. Press the down-buttons (B) and (F) to lower the left and right boom wings, until they rest in the transport brackets.

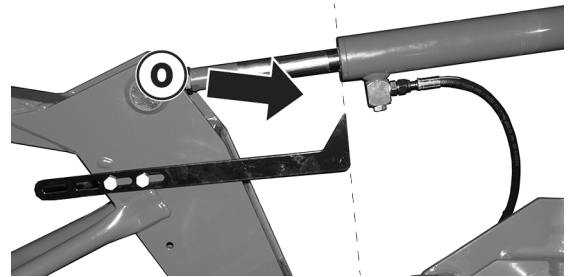
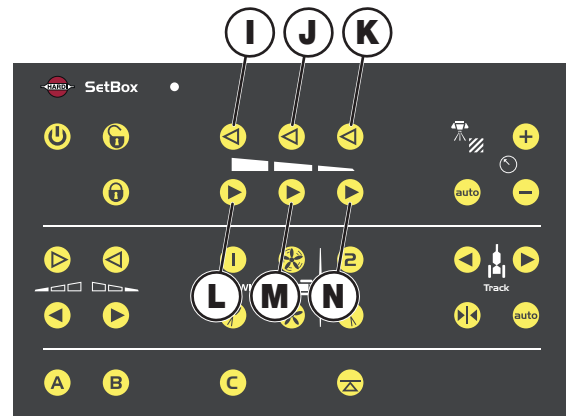

5 - Operation

Single-side Half Boom Wing (Option for 2-fold booms)

It is possible to spray with only the inner wing unfolded at one of the boom wings. This function is useful when spraying close to obstacles and in areas where a fully unfolded spray boom will not fit.



ATTENTION! The single-side half boom wing system has been designed to bypass obstacles and operate in narrow spaces, for a short duration only, and not for a continuous spray job of larger areas.

Procedure

1. Unfold the boom as explained in "Manoeuvring of the Boom (Z-versions)" on page 96, and start the spray job.
2. When necessary to pass an obstacle during the spraying, stop the sprayer.
3. Lock the pendulum.
4. Fold either the left or right outer boom wing.
5. On the Grip, turn Off the spray sections placed on the outer boom wing just folded.
6. Continue spraying around the obstacle at a speed not exceeding 2 km/h.



ATTENTION! Do not unlock the pendulum, when spraying with a half unfolded spray boom.

7. When the obstacle is passed, stop the sprayer.
8. Unfold the outer wing and then unlock the pendulum.
9. Turn On the closed spray sections and continue spraying at normal spraying speed.



WARNING! Spraying with one boom wing half unfolded, must be done at a reduced speed not exceeding 2 km/h. Failure to do so may damage the boom!



WARNING! Failure to comply with the above mentioned guidelines, will damage the sprayer due to asymmetrical load and operation with the pendulum locked.

Single-side 2/3 Boom Wing (Option for 3-fold booms)

It is possible to spray with only the inner wing and the 1st outer wing unfolded at one of the boom wings. This function is useful when spraying close to obstacles and in areas where a fully unfolded spray boom will not fit.



ATTENTION! The single-side 2/3 boom wing system has been designed to bypass obstacles and operate in narrow spaces, for a short duration only, and not for a continuous spray job of larger areas.

Procedure





1. Unfold the boom as explained in "Manoeuvring of the Boom (Z-versions)" on page 96, and start the spray job.
2. When necessary to pass an obstacle during the spraying, stop the sprayer.
3. Fold either the left or right 2nd outer boom wing.
4. If the boom slants, then compensate by adjusting the slant angle.
5. On the Grip, turn Off the spray sections placed on the 2nd outer boom wing just folded.
6. Continue spraying around the obstacle, etc.
7. When the obstacle is passed, stop the sprayer.
8. Unfold the 2nd outer wing and if necessary re-adjust the slant angle.
9. Turn On the closed spray sections and continue spraying.



WARNING! Failure to comply with the above mentioned guidelines, will damage the sprayer due to asymmetrical load and operation with the pendulum locked.

Night Spraying Light (Optional)

The night spraying light is activated in the SmartCom controller.

1. Press  to enter the options menu.
2. Press  to enter the Night Spraying Light menu.
3. Press  to turn on the night spraying lights.
4. Press  to turn off lights again.

 **NOTE!** Activates two boom spotlights and two under-boom lights.

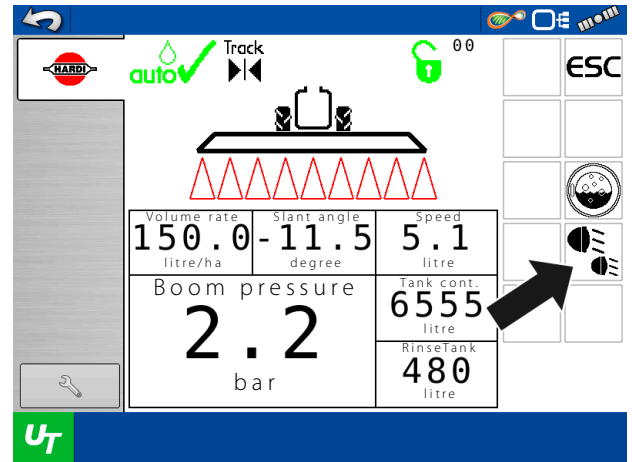

Under boom lights (A) are positioned under the boom to illuminate the spray pattern.

Underboomlights (A) are turned on/off on the controller in the tractor.

The floodlights (B) are also mounted to the railing of the platform above the valves. These are positioned to illuminate the zone in front of the booms.

The work light (C) is mounted to the railing of the platform above the valves. This lamp is positioned to light up the TurboFiller and the valve system.

The floodlights (B) and under boom lights (A) are turned ON and OFF from the UT screen in the tractor cabin.

The work light (C) automatically turns on when the left side cover is opened.

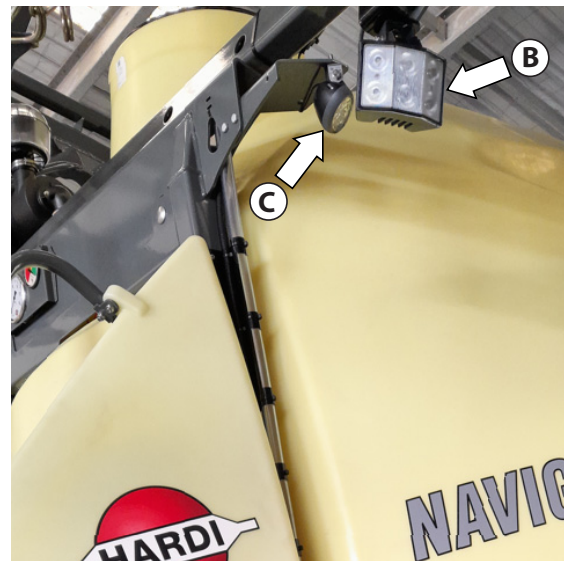
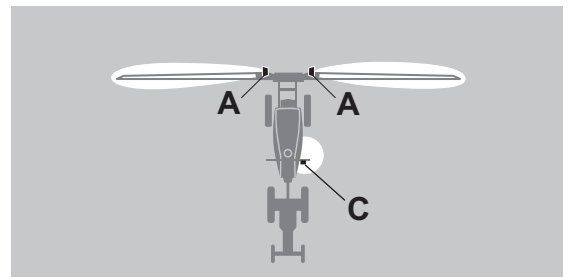

 **ATTENTION!** It is recommended to switch OFF the rear working lights of the tractor in order to save power consumption and to avoid reflection.

Turn OFF all work lights and night lights, when driving on public roads!

If the lights do not function, check the cable connections and check if the fuses are blown.

Check frequently that the lights are clean and without damages. Clean with a dry cloth if needed. Replace if broken.

5 - Operation

Liquid System

General Info

i NOTE! Please refer to the Spray Technique book for instructions on the use of filters, nozzles etc., and their combination in use with specific spraying applications.

Quick Reference - Operation

In the following diagram, the handle positions for different options are illustrated.

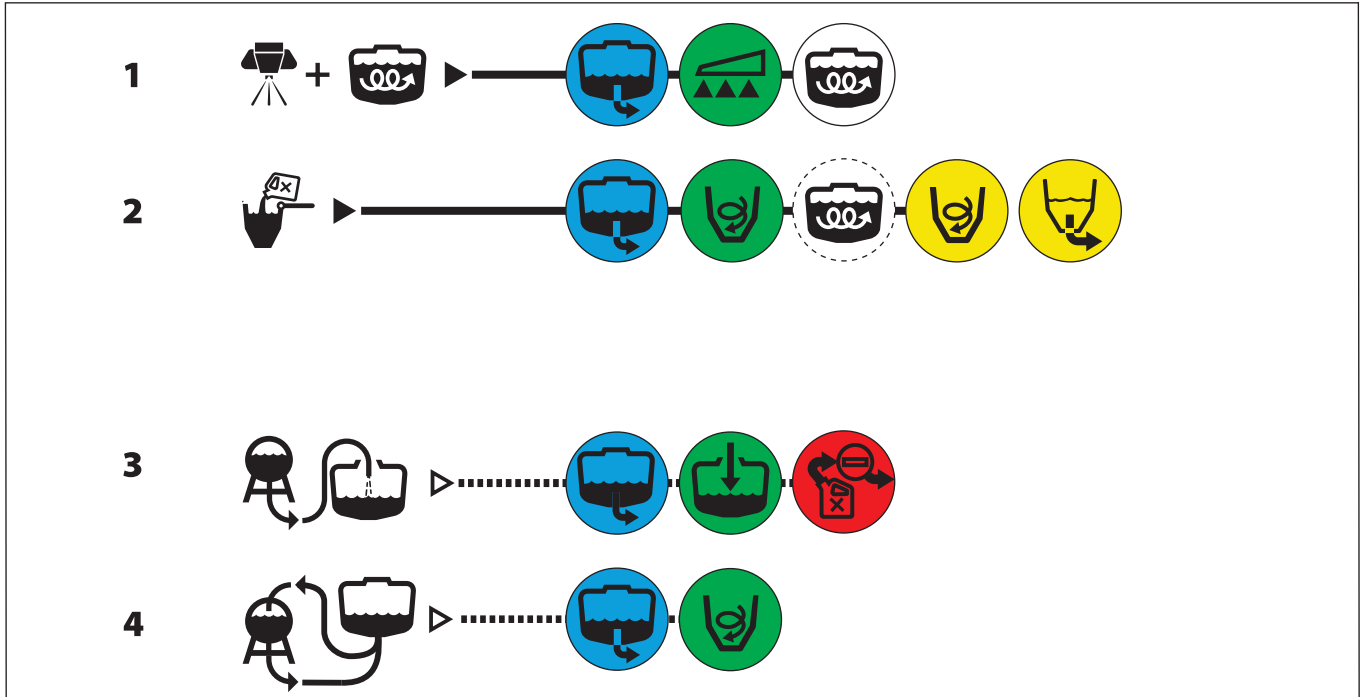

i NOTE! Dashed lines and valve symbols, indicates optional equipment and functions.

1. Spraying with suction from the MainTank and using agitation in the MainTank.
2. Filling chemicals using the TurboFiller with suction from the MainTank. Using agitation is optional.
3. Filling of the MainTank/FlushTank via CleanWaterFill point through Filtered Fill. (Banjo pump as optional) (Clean water only).
4. Filling chemicals through chemical probe.
5. Drain/Batchfill for draining or filling the MainTank.

i NOTE! Contaminated water can be filled through batch fill point.

⚠ WARNING! Chemicals must not be used at the CleanWaterFill point as they will contaminate the flush tank!

Filling/Washing Location Requirements

When filling the sprayer with chemicals and water, it is important to avoid spot contamination by spraying chemicals in order to protect subsoil water resources.

Dedicated Filling Site

If the sprayer is always filled on the same location, a special filling/washing location should be established. This should have a hard, liquid-impenetrable surface (e.g. concrete) secured against seepage, together with edges secured against run-off to the surrounding areas. The location should be drained to an adequate receptacle (e.g. slurry tank or similar).

Any spillage or washings should be retained and diluted in order to be distributed in a larger area. This is to ensure minimal environmental impact and avoid build-up of larger chemical concentrations at one spot.

If no other requirements of distances exist, the following general recommendation of distance can be used. Filling location must be no closer than:

1. 50 metres from public water supplies for drinking purposes.
2. 25 metres from non-public water supplies for drinking purposes and from treatment sumps and cesspools of drainage systems.
3. 50 metres from surface water (watercourses, lakes and coastal waters) and from nature reserves.

In the Field

Alternatively the sprayer can be filled in the field, where the spraying is to take place. If so, choose a different location for each refilling.

If no other requirements of distances exist, the filling should not take place closer than:

1. 300 metres from public or non-public water supplies for drinking purposes.
2. 50 metres from surface water (watercourses, lakes and coastal waters), treatment sumps, cesspools of drainage systems, and nature reserves.



ATTENTION! Legislation and requirements may vary. Always follow local legislation in force.



ATTENTION! It is the responsibility of the sprayer owner/operator to comply with all relevant legislation. HARDI cannot undertake any responsibilities for incorrect operation or misuse.

5 - Operation

Valves and Symbols

Coloured identification on the function labels distinguish the possible valve functions. The modular valve system facilitates the addition of optional extras on both pressure side and suction side.

Activate a function by turning the handle towards the desired function.



ATTENTION! If a valve is too tight to operate, or too loose (= liquid leakage, the valve needs to be serviced. Please see "3-Way Valve Adjustment" on page 166 for further information.

Pressure SmartValve (Green Symbols)

By using this valve, route the pressurized liquid from the pump to the desired function.

The indicator indicates the active function.

Turn the handle so the desired symbol is just below the indicator mark. If the handle is turned to a position without label with a symbol (unused function), the valve is closed.



Chemical Suction



Spraying



Internal tank cleaning
(Rinsing nozzles)



TurboFiller

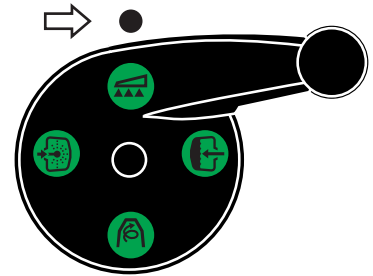

Suction SmartValve (Blue symbols)

This valve is to select suction from main tank or from rinsing tank.

Turn the handle so the desired symbol is just below the indicator mark. If turning the handle to an unused function, the valve is closed.



Main tank



Rinsing tank

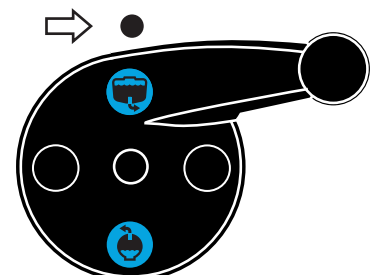

Manual Agitation Valve (Green symbols)

With the manually adjustable agitation valve, it is possible to combine spraying with a high volume rate at high pressure with agitation at the same time.

The valve continuously controls this: The valve has an arrow on the disc, which indicates the amount of liquid that passes through the valve.



Adjustable agitation

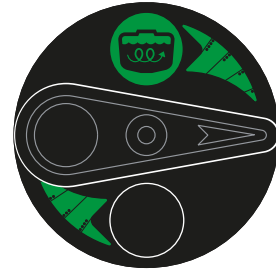

Choose your own valve setting, depending on the tank contents:

- The handle is turned to a position near the tip of the arrow:
The valve only allows a small amount of liquid to pass, resulting in a lesser extent of agitation. This is recommended when using chemicals with a low density to prevent foaming in the tank.
- The handle is turned to a position in the wide end of the arrow:
A large amount of liquid will pass the valve, resulting in a large extent of agitation. This is recommended when using chemicals with a high density, which will tend to settle at the bottom of the tank.

5 - Operation

Filling of Tanks

Filling the CleanWaterTank

To fill the CleanWaterTank:

1. Remove the tank lid.
2. Fill with clean water.
3. Refit the tank lid.

The water in this tank is for hand washing, for cleaning of clogged nozzles etc. Only fill this tank with clean water from the tap.

For use of water:

Turn the lever to open the ball valve. The ball valve is located on the left side of the sprayer next to the EasyCleanFilter. The water from this tank is for hand washing, cleaning of clogged nozzles etc.

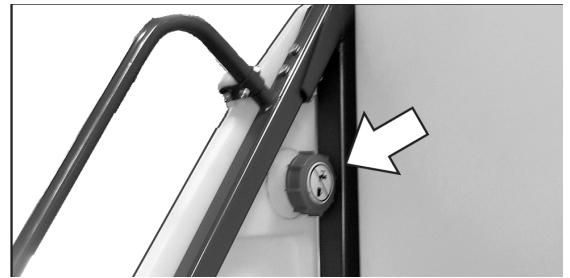

WARNING! Although the CleanWaterTank is only filled with clean water, this water must NOT be used for drinking.



ATTENTION! Only fill the CleanWaterTank with clean water! To avoid algae developing in the tank. Always drain the CleanWaterTank, if the sprayer is not in use for a longer period of time.

Filling of Water

The tank should normally be filled 1/3 with water before adding chemicals. Always follow the instructions given on the chemical container!



WARNING! If the sprayer is put aside with liquid in the MainTank, all manifold valves must be closed.



WARNING! Sprayer must be connected to the tractor before filling either the main or the flush tank.



WARNING! Do not disconnect the sprayer from the tractor if there is liquid in either the main or the flush tank.

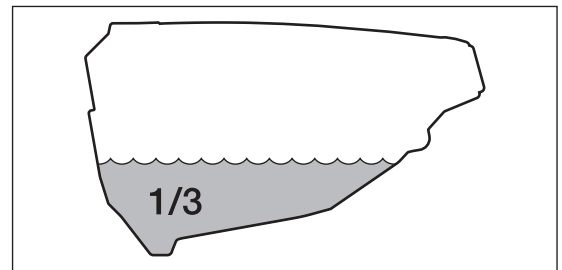

Filling the RinseTank (Filtered - External pump)

The 'Filtered Fill system' allows the operator to fill the sprayer from an external water source (such as a dam or tank) using an auxiliary pump. The system includes a cam-lock coupling on the inlet and a high capacity in line filter.



The RinseTank is filled via the CleanWaterFill point 2" cam-lock connection (A):

1. Remove the filler cap and fit the external water hose to the cam-lock connection piece.
2. Turn the pump "ON".
3. Select RinseTank (F) on rocker switch.
4. Open the cam-lock valve.
5. Keep an eye on the level indicator in order not to overfill the tank.
6. When finished close the cam-lock valve.
7. Turn the pump "OFF", refit the cap.

Volume: approximately 500 litres.



ATTENTION! Only fill the RinseTank with clean water! To avoid algae developing in the tanks. Always drain the RinseTank, if the sprayer is not in use for a longer period.



ATTENTION! For cleaning and inspection purpose, the RinseTank is accessible via the tank lid on top of the tank.



A



5 - Operation

Filtered Fill system (Filtered - External pump)

The 'Filtered Fill system' allows the operator to fill the sprayer from an external water source (such as a dam or tank) using an auxiliary pump. The system includes a cam-lock coupling on the inlet and a high capacity in line filter.





The MainTank is filled via the CleanWaterFill point using 2" cam-lock connection (A):

1. Remove the filler cap and fit the external water hose to the cam-lock connection piece.
2. Turn the pump "ON".
3. Select MainTank (M) on rocker switch.
4. Open the cam-lock valve.
5. Keep an eye on the level indicator in order not to overfill the tank.
6. When finished close the cam-lock valve.
7. Turn the pump "OFF", refit the cap.



The Filtered Fill system can be used to fill either "Main Tank" or "Rinse Tank". The hydraulic flow is controlled by a flow controller located in the workstation.

 **WARNING!** Do not leave the sprayer while filling the tank and watch the tank gauge closely to prevent over filling.

 **ATTENTION!** Due to risk of contamination it is prohibited in some areas to fill a sprayer from open water ways such as lakes and rivers etc. Contact your local authorities for information about laws specific to your area.

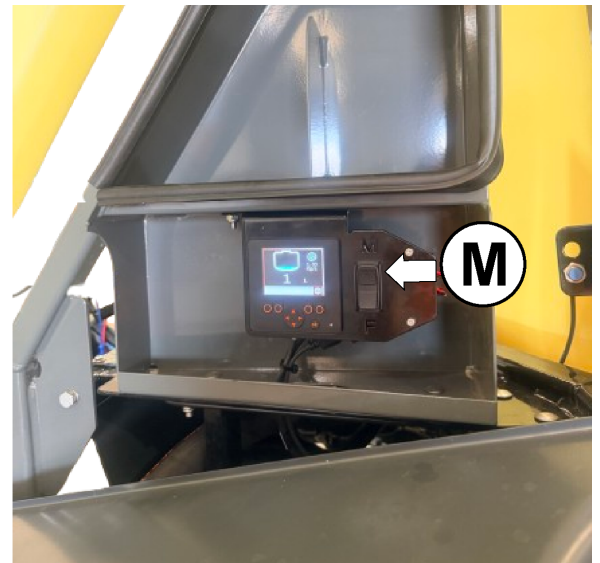

Hydraulic Filtered Fill System (with high capacity Banjo Pump) (Optional)

The 'Banjo Filtered Fast Fill' system employs a high capacity centrifugal pump (P) driven by a hydraulic drive motor (M). The motor is powered by the tractor's auxiliary hydraulics. The operator can control the flow rate of the pump by use of a variable speed control valve (V) located on a panel on the left hand side of the machine.



ATTENTION! Do not attempt to run the pump over the recommended Maximum speed.



ATTENTION! The hydraulic flow rate should be limited to a maximum of 40 l/min.

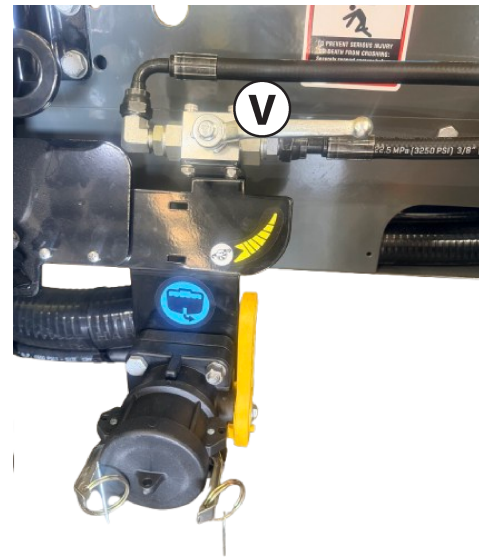

Operation

To fill the sprayer using the 'Banjo' fast fill system:

1. Park the tractor and sprayer on a level surface, select neutral gear, apply the hand brake and engage the auxiliary hydraulics.
2. Remove the cover from the Cam-lock coupling (A) and connect a suction hose to a water source.
3. Select (M) or (F).
4. Start banjo pump.
5. Open the ball valve (B) and gradually engage the hydraulic speed control valve (V) until the desired flow rate is achieved.
6. When filling is complete dis-engage the hydraulic speed control (V) and close the ball valve (B).
7. Remove the suction hose and replace the cam-lock cap (A).



5 - Operation

Filling of Chemicals

Safety Precautions - Crop Protection Chemicals

Always be careful when working with crop protection chemicals!



WARNING! Always wear proper protective clothing before handling chemicals!

Personal Protection

Depending on chemical type, avoid contact with the chemicals by wearing personal protective equipment, such as:



Chemical-resistant gloves



Eye protection



Chemical-resistant and disposable overalls



Breathing protection



Water-resistant footwear



Headgear or Face shield



WARNING! Use protective clothing/equipment, when preparing the spray liquid, during the spray job and when cleaning the sprayer. Follow the chemical manufacturer's instructions given on the chemical label and/or local legislation.



WARNING! It is always advisable to have clean water available, especially when filling the sprayer with chemicals.



WARNING! Always carefully clean the sprayer immediately after use.



WARNING! Only mix chemicals in the tank according to directions given by the chemical manufacturer.



WARNING! Always clean the sprayer before changing to another chemical.

TurboFiller

Operating the TurboFiller

The TurboFiller is where you add the chemicals to be mixed with water in the MainTank.

Capacity: approximately 35 litres.

Before Use

- Pull the locking lever (A) down to unlock the position of the TurboFiller.
- Grab the handle (B) and pull the TurboFiller downwards.
- Lower the TurboFiller to the stop and let go of the locking lever (A) to lock the position.
- Lift off the lid (C) and place it at the handle in front of the hopper (D) as shown below.
- Place the chemicals for the coming spray job nearby ready to be filled into the TurboFiller.

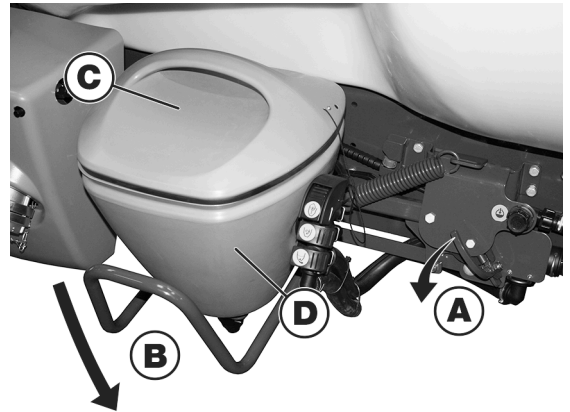

Below a short description on how to operate the valves by using the levers on the side of the TurboFiller.

For more details, see the following sections in this Instruction Book about the procedure for operating the TurboFiller while filling chemicals.

TurboFiller Suction Valve

The valve is used simultaneously with the TurboFiller. The valve has 2 settings: Continuously open or spring-loaded normally closed.

Open the valve by lifting the lever up, when chemicals are to be filled into the TurboFiller and transferred to the MainTank.

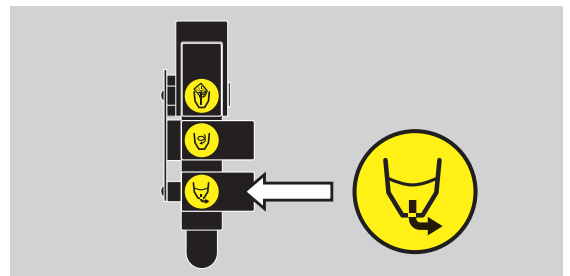

TurboDeflector Valve

This TurboDeflector valve activates the vortex flushing of the TurboFiller. Lift the lever to lock it in open position for continuous liquid rotation in the hopper.

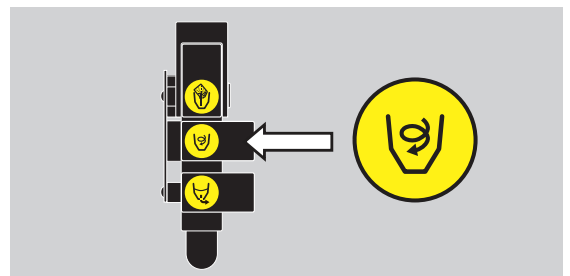

Rinsing of Chemical Containers

The upper lever is used for two purposes.

1. When the TurboFiller lid is open:
For rinsing empty containers. Place the container over the rotating flushing nozzle in the middle of the TurboFiller to rinse the inside of the container.
2. When the TurboFiller lid is closed:
Use the lever to rinse the hopper, when the filling of chemicals is completed.

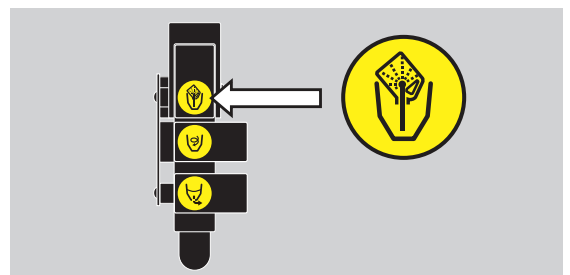

DANGER! Do not activate this lever, unless the multi-hole nozzle is covered by a container, as spray liquid may otherwise hit the operator! Risk of injuries and spillage on the ground.

5 - Operation

After Use

- Clean the inside of the TurboFiller with the spray gun (E) to remove chemical residues.
- Place the spray gun in its storing position.
- Put the lid on top of the TurboFiller.
- Pull the locking lever (A) down to unlock the position of the TurboFiller.
- Grab the handle above and push the TurboFiller upwards.
- Raise the TurboFiller to the storage position and let go of the locking lever to lock the position.

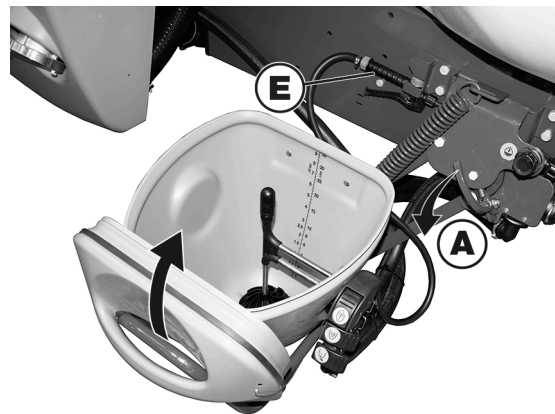

Filling Liquid Chemicals Using the TurboFiller



ATTENTION! We advise to use the TurboFiller, when you fill chemicals on the sprayer.

1. Fill the MainTank at least 1/3 with water (unless otherwise stated on the chemical container label).
2. Turn the handle of the suction SmartValve towards "MainTank".
3. Turn the pressure SmartValve towards "TurboFiller".
4. Close the agitation valve.



ATTENTION! If filling water from an external tank, it is possible to continue this while doing the next steps.



DANGER! It is very important to ensure that the quick coupler lid is correctly and completely fitted to the filling stud in its locked position, before turning pressure SmartValve to "Pressure draining/TurboFiller". Failure to do so may cause risk of contamination and injury from quick coupler lid being "shot" off when pressurized! If not possible to fit the lid completely, lubricate the rubber seal and the grip hooks.

5. Engage the pump and set PTO speed at max. 540 RPM or 1000 RPM (depending on pump model).



DANGER! Always wear face shield and other appropriate personal safety equipment, when filling chemicals.



ATTENTION! Only use the scale in the hopper, if parking the sprayer on level ground! Recommended is to use a measuring jug for best accuracy.

6. Engage the hopper transfer device by opening the TurboFiller suction valve to transfer chemicals to the MainTank. The TurboFiller suction valve must be open for at least 20 seconds after the chemical is no longer visible in the hopper, in order to empty the transfer hoses completely into the MainTank.

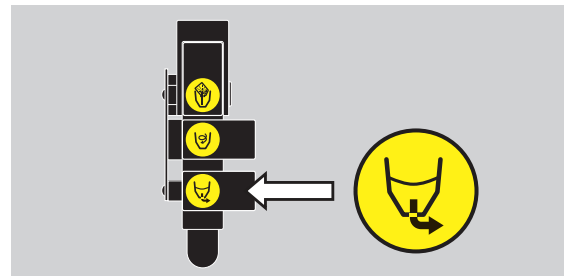

DANGER! If the TurboFiller and the transfer hoses not completely emptied, there is a risk of chemicals flowing back into the hopper!

7. If the chemical container is empty, the "chemical container cleaning device" can rinse it. Place the container over the multi-hole nozzle and push the lever to activate container cleaning.

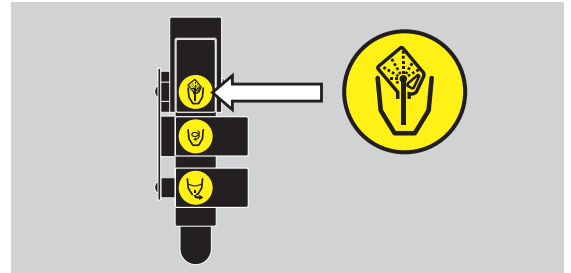

DANGER! In order to avoid spray liquid hitting the operator, do not press the lever unless covering the multi-hole nozzle with a container, as spray liquid may otherwise hit the operator!



ATTENTION! The rinsing device uses spray liquid to rinse containers for concentrated chemicals. Before disposal, always rinse the chemical containers with clean water several times, until they are clean.

8. Flush the TurboFiller with clean water by shifting to suction from the RinseTank or from an external tank. The TurboFiller suction valve must be open for at least 20 seconds after the rinse water is no longer visible in the hopper, in order to empty the transfer hoses completely into the MainTank.



ATTENTION! If not shifting the suction SmartValve to suction from a clean water supply, the hopper-rinsing device uses spray liquid for rinsing the hopper! Always clean the TurboFiller when the spray job is ended, and together with cleaning the entire sprayer. A cleaning after the last filling, and before spraying, does not ensure a clean TurboFiller!

9. When the hopper rinsing end, close the TurboFiller suction valve. Close the TurboFiller lid.
10. If closed, turn the agitation valve towards "Agitation".



ATTENTION! If foaming is a problem, reduce the agitation.

11. When the spray liquid is well agitated, turn the handle for pressure SmartValve towards "spraying" position. Continue agitation during spraying of the crop.

5 - Operation

Filling Powder Chemicals Using the TurboFiller

1. Fill the MainTank at least 1/2 with water (unless otherwise stated on the chemical container label). See section "Filling of water".
2. Turn the handle of the suction SmartValve towards "MainTank".
3. Turn the pressure SmartValve towards "TurboFiller".
4. Turn the agitation valve towards "agitation" as required:
 - A fully open agitation valve will result in very little suction from the TurboFiller.
 - A fully closed agitation valve will result in no agitation, while transferring the powder into the tank, resulting in poor mixing.
5. Close the remaining valves.



ATTENTION! For increased suction from the TurboFiller, keep the agitation valve closed.



ATTENTION! If filling water from an external tank, it is possible to continue this while doing the next steps.



DANGER! It is very important to ensure that the quick coupler lid fits correctly and completely to the filling coupler in its locked position, before turning pressure SmartVvalve to "Pressure draining/TurboFiller". Failure to do so may cause risk of contamination and injury from the quick coupler lid being "shot" off when pressurized! If not possible to fit the lid completely, lubricate the rubber seal and the grip hooks.

6. Engage the pump and set PTO speed at max. 540 RPM or 1000 RPM (depending on pump model).
7. Open the TurboFiller lid. Open the TurboDeflector valve and the TurboFiller suction valve.
8. Measure the correct amount of powdered chemical and sprinkle it into the hopper as fast as the transfer device can flush it down.
9. The TurboFiller suction valve must be open for at least 20 seconds after the chemical is no longer visible in the hopper, in order to empty the transfer hoses completely into the MainTank.

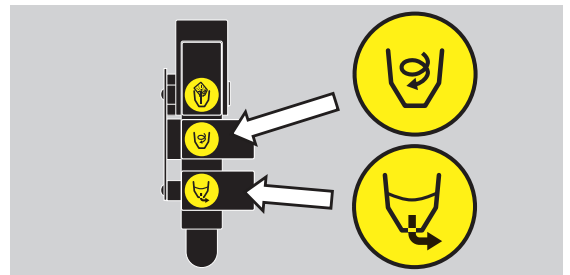

DANGER! If the TurboFiller and the transfer hoses not completely emptied, there is a risk of chemicals flowing back into the hopper!



DANGER! Always wear face shield and other appropriate personal safety equipment, when filling chemicals.

10. If the chemical container is empty, then it rinse by using the "chemical container cleaning device". Place the container over the multi-hole nozzle and push the upper lever to the left of the TurboFiller.



DANGER! In order to avoid spray liquid hitting the operator, do not press the lever unless covering the multi-hole nozzle with a container, as spray liquid may otherwise hit the operator!

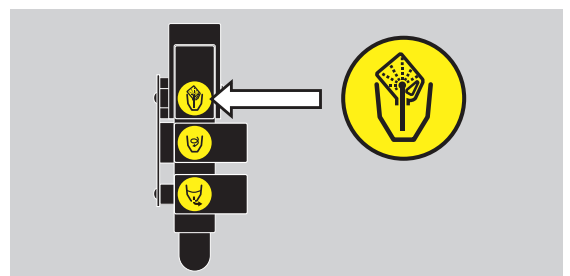

ATTENTION! The rinsing device uses spray liquid to rinse containers for concentrated chemicals. Always rinse the chemical containers with clean water several times, until they are clean before disposal.

11. Flush the TurboFiller with clean water by shifting to suction from the RinseTank or from an external tank. The TurboFiller suction valve must be open for at least 20 seconds after the rinse water is no longer visible in the hopper, in order to empty the transfer hoses completely into the MainTank.



ATTENTION! If not shifting the suction SmartValve to suction from a clean water supply, the hopper rinsing device uses spray liquid for rinsing the hopper! Always clean the TurboFiller when the spray job is ended, and together with cleaning the entire sprayer. A cleaning after the last filling, and before spraying, does not ensure a clean TurboFiller!

12. When the hopper rinsing end, close the TurboFiller suction valve. Close the TurboFiller lid.
13. If closed, turn the agitation valve towards "agitation".
14. When the spray liquid is well agitated, turn the handle for pressure SmartValve towards "spraying" position. The agitation continues during spraying of the crop.



ATTENTION! If foaming is a problem, turn down the agitation.

5 - Operation

TurboFiller Rinsing



NOTE! It is important to source clean water from the RinseTank or an external tank with clean water.

Rinse the TurboFiller and chemical containers as follows:

Cleaning Empty Containers - TurboFiller Lid is Open

1. Put container over the rotating flushing nozzle in the middle of the TurboFiller, so that the nozzle is inside the container.
2. Simultaneously press the chemical container cleaning lever and the TurboFiller suction valve. This rinses the chemical container with the flushing nozzle, while the rinsing liquid is emptied out of the TurboFiller.

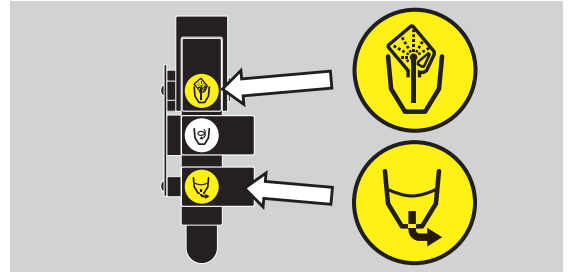

TurboFiller Rinsing - TurboFiller Lid is Closed

1. Close TurboFiller lid.
2. Turn the suction SmartValve towards "Rinsing tank" or "External Filling Device", if clean water is available here.
3. Open the Turbo Deflector Valve  for 1 minute to get plenty of clean water through the hoses.
4. Simultaneously press the Chemical Container Cleaning lever and the TurboFiller suction valve. This rinses the hopper with the flushing nozzle, while the rinsing liquid is emptied out of the TurboFiller.
5. Rinse the hopper for 30-40 seconds.
6. Open the lid to inspect if the TurboFiller is empty. If not, close the lid again and press the TurboFiller suction valve, until the TurboFiller is empty.
7. After the last flushing, the TurboFiller suction valve must be open for at least 20 seconds, after the rinse water is no longer visible in the hopper, in order to completely empty the transfer hoses into the main tank.



ATTENTION! Always clean the TurboFiller thoroughly after spraying. This is to ensure that it is clean, before spraying other crops that may be sensitive to the chemicals just used. See the section "Cleaning" on page 118 for details.

Filling chemicals through chemical probe

1. Turn the Pressure SmartValve to chemical suction probe.
2. Select Suction SmartValve to the required source.
3. Remove the cam-lock cover and connect the hose at (A).
4. Turn the chemical fill handle (B) to "ON" position (pointing downwards).
5. Once the filling is completed, turn the chemical fill handle to "OFF" position (pointing horizontal).
6. Disconnect hose and put the cam-lock cover on.



5 - Operation

In-field Operation

Operating the Control Units While Spraying

The control units in the tractor control the following functions in the field:

i NOTE! For further details of use, please refer to the SmartCom UT instruction book.

SetBox Controls (Optional)

	Power ON/OFF/status, LED light. The light must be ON and blinking.
	Automatic spray pressure regulation. The regulation valve controls the main spray pressure. This is default selection when the controller is powered ON, and it should remain here during normal spraying.
	Manual spray pressure regulation. During normal spraying, these regulations should not be used, as the regulation valve does this automatically.
	The IntelliTrack function is used, when making turns in the field, ensuring: <ul style="list-style-type: none"> - a small turning radius. - a better stability when turning. - that the spray boom is perpendicular to the crop rows. Press "auto" for automatic adjustment of the sprayer. Press left or right arrow key to manually adjust the sprayer tracking.
	Optional function, A or B. If extra equipment is fitted, it can be controlled from here.

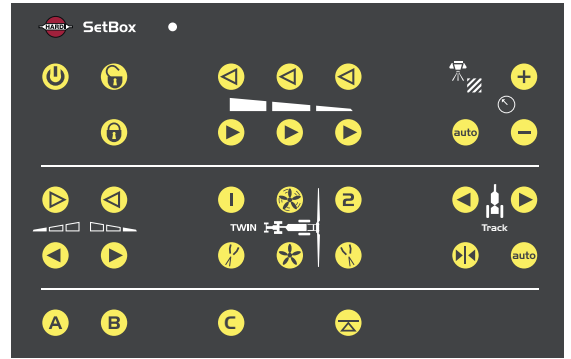

Grip Controls - Spray and Track Functions (Optional)

- A. Power ON/OFF/status LED light. The light must be ON and blinking and blinking.
- B. Distribution valves for the spray boom. Turns separate spray sections On or Off.
 - The switch is in up position: OFF.
 - The switch is in down position: ON.
- C. Main valve ON/OFF.

i NOTE! Check the current volume application rate on the display, or see the instruction book for the spray controller for more information.

D. Thumbstick:

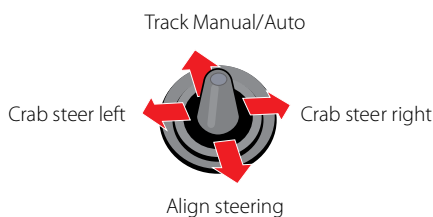

E. Not used.

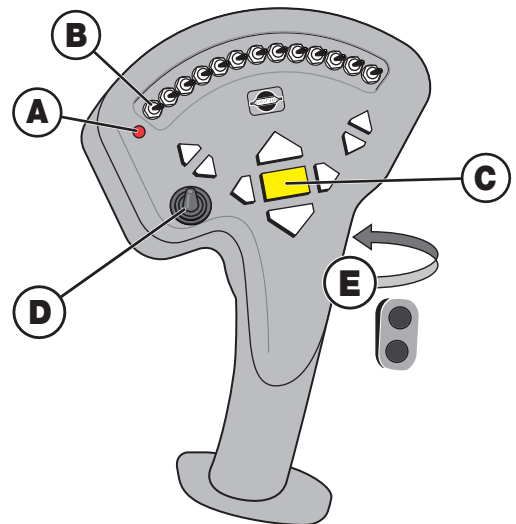

Agitation Before Resuming a Spray Job

If interrupting a spray job for a while, severe sedimentation may occur depending on the chemicals being used. Before resuming the spray job, it might be necessary to agitate sediment material.

1. Turn the handle at the suction valve towards "Suction from main tank".
2. Turn the pressure SmartValve towards "TurboFiller".
3. Turn the agitation valve towards "Agitation".

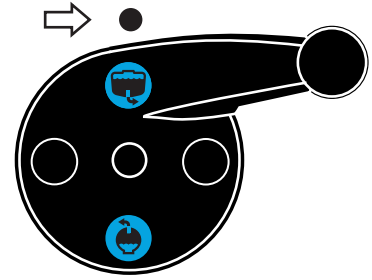

DANGER! It is very important to be sure that the quick coupler lid is correct and completely fitted to the filling stud into its locked position, before turning pressure SmartValve to "TurboFiller". Failure to do so may cause risk of contamination and injury from quick coupler lid being "shot" off when pressurized! If not possible to fit the lid completely, lubricate the rubber seal and the grip hooks.

4. Engage the pump and set PTO speed to max. 540 RPM or 1000 RPM (depending on pump model).
5. Agitation has started and should be continued for at least 10 minutes.

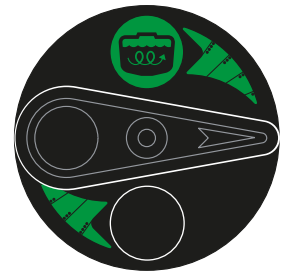
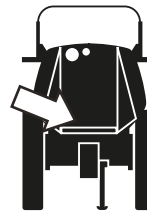

The spray job can now be resumed. Turn pressure SmartValve towards "Spraying" and start spraying.

Before Returning to Refill the Sprayer

If refilling the sprayer at the farm, or at a fixed filling place without a filling space with hard surface and drain to a closed reservoir, then rinse sprayer before returning to refill.

Dilute the residues of the spraying circuit, and spray it on the crop. Depending on the weather conditions, it could also be necessary to clean the sprayer on the outside now while in the field, before returning to the farm.



WARNING! Always follow local legislation in force at any time.

Parking the Sprayer

To avoid spot contamination, the sprayer should always be parked at either the washing/filling location or under cover.

This prevents rainfall from washing down chemical residue from the sprayer's surfaces.

- Parking at the washing/filling location will retain residues.
- Always park the machine out of reach of children, animals and unauthorized persons.
- Always follow local regulations when parking your sprayer.

5 - Operation

Cleaning

General Info

Follow the below cleaning and maintenance program, in order to derive full benefit from the sprayer for many years.



ATTENTION! Always read the individual paragraphs. Carefully read the instructions for cleaning/maintenance jobs before starting on the job. If any portion remains unclear, or if it requires facilities not available, then please leave the job to your HARDI dealer's workshop for safety reasons.



ATTENTION! A clean sprayer:

- Is a safe sprayer.
- Is ready for action.
- Reduces risk of crop damage from crop protection chemical residue.

Guidelines

- Read the complete chemical label. Take note of any particular instructions regarding recommended protective clothing, deactivating agents, etc. Read the detergent and deactivating agent labels. If cleaning procedures are given, follow them closely.
- Be familiar with local legislation regarding disposal of chemical washings, mandatory decontamination methods, etc. If in doubt, contact the appropriate authority.
- Usually the chemical washings are sprayed out on the field just sprayed or at a suitable area. Avoid emptying the washings at the same spot every time and keep sufficient distance to the water environment. You must prevent seepage or runoff of residue into streams, watercourses, ditches, wells, springs, etc. The washings from the cleaning area must not enter sewers. Alternatively, retain the washings in an appropriate receptacle, diluted and distributed over a larger cultivated area - also see "Filling/Washing Location Requirements" on page 101.
- Cleaning starts with the calibration, as a well-calibrated sprayer will ensure the minimal amount of remaining spray liquid.
- Good practice is to clean the sprayer immediately after use, and thereby rendering the sprayer safe and ready for the next pesticide application. This also prolongs the life of the components. Strongly advised is to perform an internal cleaning of the sprayer, when high concentrations of acids or chloride are present in the active ingredients, or if the spray liquid is corrosive. For the best result, use a cleaning agent.
- Sometimes it is necessary to leave spray liquid in the tank for short periods, e.g. overnight, or until the weather becomes suitable for spraying again. Unauthorized persons, children and animals must not have access to the sprayer under these circumstances.
- Recommended is to coat all metal parts of the sprayer before and after use with a suitable rust inhibitor, if the product applied is corrosive.
- Always park the sprayer under cover to avoid rain-washing off pesticides causing spot contamination in the soil. If parked outside, park the sprayer on the filling/washing location in order to retain possible pesticides.

Quick Reference - Cleaning

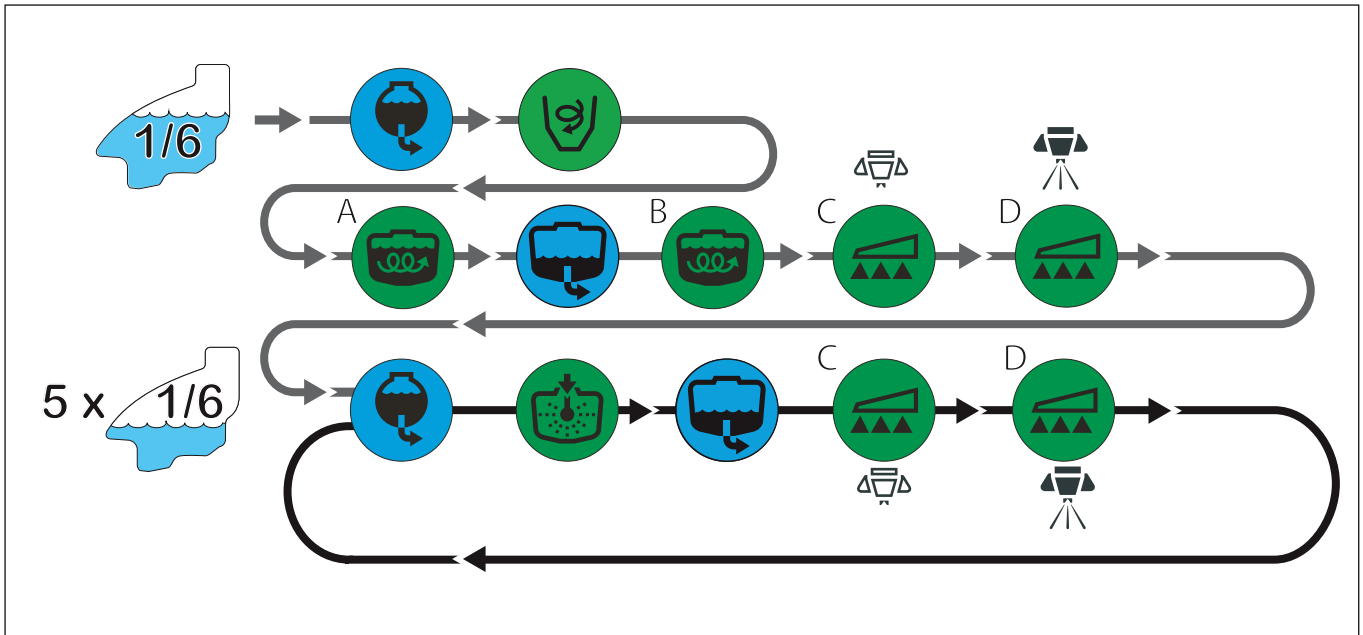

ATTENTION! Set pump speed to 250-280 rpm.

Using on-screen functions

- A. Turn On
- A. Turn Off.
- B. Minimum 45 seconds with nozzles Off.
- C. Spray until air comes out of nozzles.

When the pressure drops, close the regulation valve by pressing the  spray pressure button on the screen, until yellow LED lights on the valve (this can take up to 10 seconds).





With DF4 system: Press "auto"  to have the system remove pressure spikes automatically before next start-up.

5 - Operation





Standard Cleaning using On-screen Functions



ATTENTION! For cleaning between spray jobs, where crops are not very sensitive towards chemicals just sprayed.

1. Engage the pump with tractor in idle, so that pump speed is as low as possible (approx. 250-280 or 550-580 RPM, depending on pump type).
2. Turn the suction SmartVvalve towards  and the pressure SmartValve towards  while transferring approximately 1/6 of the RinseTank content into the MainTank.
It is important to have full agitation for approximately 20 seconds; and then completely close the agitation valve.
3. Turn the suction SmartVvalve towards  and the pressure SmartValve towards  with all boom sections OFF for approximately 45 seconds.
4. Switch all boom sections ON. Spray until air comes out of the nozzles.
5. When the pressure drops, close the regulation valve by pressing the spray pressure switch on the SprayBox upwards (increase pressure), until yellow LED lights on the valve (this can take up to 10 seconds).
6. Press "auto" to have the system remove pressure spikes automatically before next start-up.

Repeat the Following Three Steps 5 Times

7. Turn the suction SmartVvalve towards  and the pressure SmartValve towards  while transferring approximately 1/6 of the RinseTank content into the main tank.
8. Turn the suction SmartVvalve towards  and the pressure SmartValve towards  with all boom sections OFF for approximately 45 seconds.
9. Switch all boom sections ON. Spray until air comes out of nozzles.
10. When the pressure drops, close the regulation valve by pressing the spray pressure switch on the SprayBox upwards (increase pressure), until yellow LED lights on the valve (this can take up to 10 seconds).
11. Press "auto" to have the system remove pressure spikes automatically before next start-up.

General Cleaning of MainTank and Liquid System

In the following, the cleaning procedure described in general terms.



ATTENTION! Thorough cleaning of the sprayer is to be carried out when shifting to crops, which are very sensitive to chemicals just sprayed, or prior to storage for a longer period.



NOTE! Prior to the described cleaning:

- Carry out a standard cleaning.
 - Select and use the appropriate protective clothing. Select detergent suitable for cleaning and suitable deactivating agents if necessary.
 - Rinse and clean the sprayer and tractor externally. Use detergent if necessary.
1. Remove the MainTank sieve to avoid a blind spot when rinsing the MainTank.
 2. With the pump running, rinse the inside of the MainTank. Do not forget to clean the MainTank roof. Rinse and operate all components and any equipment, which have been in contact with the chemical. Decide whether doing this in the field or on the seepage location, before opening the distribution valves and spraying the liquid out.
 3. After spraying the liquid out, stop the pump and fill at least 1/5 of the MainTank with clean water. Note that some chemicals require the MainTank completely filled. Add appropriate detergent and/or deactivating agent. Recommended is special detergents for sprayer cleaning as some also lubricate ball valves, etc.
 4. Start the pump and operate all controls enabling the liquid to expose all the components. Operate the distribution valves as the last thing. Some detergents and deactivating agents work best, if left in the MainTank for a short period. Check the chemical label.
 5. Drain the MainTank and let the pump run dry. Rinse inside of the MainTank, again letting the pump run dry.
 6. Stop the pump. If the pesticides used have a tendency to block nozzles and filters, remove and clean them immediately.
 7. Remove the suction EasyCleanFilter and the pressure CycloneFilter and clean the filter mesh. Be careful not to damage the filter mesh.
 8. Refit all the filters and nozzles and store the sprayer. If noted from previous experiences, that the solvents in the pesticides are particularly aggressive, store the sprayer with the MainTank lid open.



ATTENTION! It is advisable to increase the forward speed (double, if possible) and reduce the spraying pressure to 1.5 bar, when spraying diluted remaining liquid in the field just sprayed.



ATTENTION! If given on the chemical label, then closely follow the cleaning procedure.



ATTENTION! Recommended is lubrication of the entire machine, if cleaning the sprayer with a high-pressure washer.

5 - Operation

Cleaning and Maintenance of Filters

Clean filters ensure:

- None hindering or damage during operation on sprayer components such as valves, diaphragms and operating units.
- Nozzle clogging do not occur whilst spraying.
- Long life of the pump. A blocked suction filter will result in pump cavitation. The main filter protecting sprayer components is the suction filter. Check it regularly.



NOTE! For cleaning procedure, refer to:

- "10 Hours Service - EasyCleanFilter" on page 137.
- "10 Hours Service - CycloneFilter" on page 138.
- "10 Hours Service - Nozzle Filters (If fitted)" on page 136.
- "10 Hours Service - Suction Filter for Ace pump (Optional)" on page 140.
- "50 Hours First Service ONLY - Hydraulic Filter" on page 143.
- "250 Hours Service - Hydraulic Filter" on page 154.

Use of RinseTank and Rinsing Nozzles

The integrated RinseTank can be used for two different purposes.









ATTENTION! If a cleaning procedure is given on the chemical label, follow it closely.





In-Field Diluting Before Cleaning

In-field diluting of remaining spray liquid residue in the spraying circuit should be carried out, before cleaning the sprayer.

Rinsing the MainTank and liquid system:

1. Empty the sprayer as much as possible. Close the AgitationValve (no agitation) and spray until air comes out of all nozzles.
2. Turn the suction SmartValve towards  and the pressure SmartValve towards .
3. Engage the pump. Set the pump speed to approximately 300 RPM.
4. When 1/3 of the contents in the RinseTank is used, turn the suction SmartValve towards  and operate all valves on the pressure side of the system in the following order, so that all hoses and components are rinsed:
 - A. Turn the pressure SmartValve towards  to activate the ejector and open the TurboFiller suction valve.
 - B. Open the TurboDeflector valve and close it again, when clean water comes out of nozzles.
 - C. Close the TurboFiller lid and press the Chemical Container Cleaning lever in approximately 5 seconds to clean this device.
 - D. Open the TurboFiller lid again, and make sure that the TurboFiller is empty. When empty, close the TurboFiller suction valve again. Ensure that the External fast filling connection and the line are not contaminated with chemicals.
5. Turn the suction SmartValve towards  and the pressure SmartValve towards , and spray the liquid out in the field just sprayed.

Cleaning of MainTank:

6. Turn the suction SmartValve towards  and the pressure SmartValve towards . Remove the filling strainer to avoid any cleaning shadows behind it.
7. When another 1/3 of the contents in the RinseTank is used, turn the suction SmartValve towards .
8. Turn the pressure SmartValve towards , and spray the liquid out in the field just sprayed.
9. Repeat step 6 - 8 one more time.



WARNING! When critical chemicals (like sulphonylurea) have been used, or a cleaning detergent is recommended, do an extra cleaning:

10. Fill the RinseTank again.
11. Fill the MainTank with 500 litres of clean water.
12. Add the cleaning detergent to the MainTank by using the TurboFiller. Follow instructions on the label of the cleaning agent.
13. Clean the whole system again.
14. To get the best cleaning effect, the CycloneFilter and the EasyCleanFilter sieves should be washed with clean water.
15. Rinse the sprayer with clean water afterwards.





ATTENTION! The rinsing nozzles cannot always guarantee a 100% cleaning of the tank. Always clean manually with a brush afterwards, especially if crops, which are sensitive to the chemical just sprayed, are to be sprayed afterwards!

5 - Operation

Rinsing When MainTank Is Not Empty

Rinsing the pump, operating units, spray lines, etc. in case of stop in spraying (e.g. because of rain), before MainTank is empty.

Cleaning of the liquid system:

1. Turn the suction SmartValve towards . (Keep the pressure SmartValve in -position).
2. Close the agitation valve (no agitation).
3. To prevent diluting the tank content, close the rinsing hose for the CycloneFilter.
4. Engage the pump. Set the pump speed to approximately 300 RPM and increase the spraying pressure to 6 bar. Spray the water from the RinseTank into the field, until all nozzle tubes and nozzles have been flushed with clean water.
5. Turn Off the pump.



ATTENTION! It is advisable to increase the forward speed (double, if possible) and reduce the spraying pressure to 1.5 bar, when spraying diluted remaining liquid in the field just sprayed.

Cleaning the Sprayer on the Outside



ATTENTION! External cleaning using the spray gun is only possible with water from the RinseTank, which have been directed through the MainTank. To avoid cleaning the sprayer on the outside using concentrated chemical mix from the MainTank, do a complete MainTank cleaning before attempting to use the spray gun!

Refer to "Outside Cleaning - Use of External Cleaning Device (Manual Version) (Optional)" on page 135 for detailed procedure.



ATTENTION! If the sprayer is cleaned with a high pressure washer, lubrication of the entire machine is recommended.

Use of Cleaning Agents

- It is recommended to use an appropriate cleaning agent for cleaning agricultural sprayers.
- It is recommended to use cleaning agents containing a suitable lube or conditioner.
- If not available, and instead using triple ammonia water, it is important to rinse the liquid system immediately after, and add some lubricant to the rinsing water to prevent ball valves etc. seizing up.
- Use of automotive antifreeze/radiator coolant (ethylene glycol) will protect valves and seals from drying or seizing up.

Using the Drain Valve

The drain valve is operated from side of the sprayer and is located next to the TurboFiller.

1. Open the valve to drain the tank.

If draining residues, e.g. liquid fertilizer into a reservoir, a snap coupler with hose can rapidly be connected to the drain valve, and the liquid is safely drained.



NOTE! The main tank can be filled up through this point by using an external pump.



5 - Operation

BoomFlush - Manual Cleaning

When BoomFlush valves are fitted to the end(s) of boom piping, the cleaning procedure is as follows:

1. Follow the cleaning procedure to clean the sprayer the first two times.
2. Open all BoomFlush valves by hand.
3. Continue the cleaning procedure to clean the sprayer for the third time.
4. Close BoomFlush valves.



WARNING! To prevent contamination of the soil, the BoomFlush valves must only be opened at the last step of cleaning!

Full Internal Cleaning (Soak Wash)



ATTENTION! Always use this cleaning procedure, if one or more of these situations occur:

- A. There is risk of damage to the next crop sprayed, by sediments of the chemical just used.
- B. Right away, the same chemical or crop not used for the sprayer.
- C. Before carrying out any repair or maintenance job on the sprayer.



ATTENTION! Always washing the sprayer between jobs with incompatible crops, according to prescriptions from the chemical manufacturer. Use a commonly used cleaning agent. If your chemical prescribes a different cleaning agent and/or another cleaning procedure, you must follow that.

Procedure for Washing with a Cleaning Agent

1. Rinse the sprayer in the field (see the section "Use of RinseTank and Rinsing Nozzles" on page 130).
2. Drive to the filling location.
3. Prepare sprayer for cleaning. Fill water in the MainTank to 10% of its capacity. Fill the RinseTank completely. Later you use this water for rinsing.
4. Add the cleaning agent to the MainTank by using the TurboFiller. Follow instructions on the label of the cleaning agent.
5. Set suction SmartValve for "MainTank" and pressure SmartValve for "MainTank". Set agitation valve for "Full agitation".
6. Engage and set the pump speed at approximately 300 RPM.
7. Allow the liquid to circulate the system for 3 minutes.
8. Set the pressure SmartValve for "Pressure Emptying/TurboFiller" for minimum 10 seconds without activating the TurboFiller in order to burst and flush the safety valve.
9. Open the TurboFiller transfer valve and the deflector valve. Allow the liquid to circulate for 3 minutes.
10. Close the lid and activate the container-rinsing valve to clean the hopper on the inside.
11. Shut all three valves on the TurboFiller again.
12. Verify that all nozzles are closed. If not, press the main valve ON/OFF switch on the grip.
13. Set the pressure SmartValve for "Spraying".
14. Allow the liquid in the MainTank to circulate for minimum 3 minutes with the nozzles shut. Do this to clean the return lines from boom to tank.
15. Set the pressure SmartValve for "Tank cleaning nozzles". Allow the liquid to circulate for 3 minutes.
16. Spray out water with cleaning agent and chemical residue. Set the spray pressure at 3-5 bar.

Note that the washing water still contains active chemical and choose an appropriate area to spray this out. Alternatively, the washings can be dumped at the filling/washing location and retained in an appropriate receptacle (e.g. slurry tank or similar), in order to prevent spot contamination and accumulation.

Continue to spray until all liquid has exited from the boom pipes and nozzles.

17. Shut all nozzles with the main ON/OFF switch.
18. Rinse the sprayer again with clean water to rinse out all remains of the cleaning agent. This prevents the cleaning agent remaining in the fluid system, which could damage the next spray chemical filled into the MainTank.
19. Include rinsing of the TurboFiller in step 18. Operate all 3 valves during this process.
20. Disassemble all filters (suction, pressure, in-line and nozzle filters) and clean the filter screens using clean water and detergent and a brush.



WARNING! It is the responsibility of the sprayer operator or owner to clean the sprayer sufficiently, to prevent contamination of the environment, crop damage and health and safety hazards to the operator and the public. HARDI cannot be held responsible for any damage or incidents related to insufficient cleaning.



ATTENTION! The rinsing nozzles cannot always guarantee a 100% cleaning of the tank. Clean manually with a high pressure cleaner afterwards, especially if the next crop is sensitive to the chemical just sprayed!

5 - Operation

Technical Residue

An amount of spray liquid will inevitably remain in the system. As the pump takes in air when the tank is just about empty, spraying the crop properly is not possible.

- The technical residual is defined as:

The remaining amount of liquid in the system, when the first clear pressure drop appears on the pressure gauge.

- The dilutable volume defines by:

The spray boom width, tank size and configuration of the fluid system. The volume of the technical residual given in the table is the largest possible volume for the sprayer model.

The non-dilutable volume varies depending on the boom width and options in the fluid system. Worst-case technical residual for the sprayer with the largest tank, largest fluid system and widest spray boom stated below. A sprayer configuration with a narrower spray boom, less options or a smaller tank will result in a lesser technical residual volume.

EFC Operating Unit

NAVIGATOR 4000I									
	20 m	21 m	24 m	27 m	28 m	30 m	33 m	36 m	39 m
9 sections									
Non-dilutable EFC operating unit	15.0	15.3	16.9	19.3	19.6	21.0	22.9	24.8	-
Dilutable	35.1	35.1	35.1	35.1	35.1	35.1	35.1	35.1	-
Total	50.1	50.4	52.0	54.4	54.7	56.1	58.0	59.9	-
13 sections									
Non-dilutable EFC operating unit	21.9	22.2	24.3	27.2	27.6	29.4	31.8	34.2	36.5
Dilutable	35.1	35.1	35.1	35.1	35.1	35.1	35.1	35.1	35.1
Total	57.0	57.3	59.4	62.3	62.7	64.5	66.9	69.3	71.

NAVIGATOR 5000/6000I									
	20 m	21 m	24 m	27 m	28 m	30 m	33 m	36 m	39 m
9 sections									
Non-dilutable EFC operating unit	15.0	15.3	16.9	19.3	19.6	21.0	22.9	24.8	-
Dilutable	36.2	36.2	36.2	36.2	36.2	36.2	36.2	36.2	-
Total	51.2	51.5	53.1	55.5	55.8	57.2	59.1	61.0	-
13 sections									
Non-dilutable EFC operating unit	21.9	22.2	24.3	27.2	27.6	29.4	31.8	34.2	36.5
Dilutable	36.2	36.2	36.2	36.2	36.2	36.2	36.2	36.2	36.2
Total	58.1	58.4	60.5	63.4	63.8	65.6	68.0	70.4	72.7

Pressure Circulation, PrimeFlow, ActiveAir

NAVIGATOR 4000I									
	20 m	21 m	24 m	27 m	28 m	30 m	33 m	36 m	39 m
9 sections									
Non-dilutable	0.0	0.0	0.0	0.0	0.0	0.0	0.0	0.0	0.0
Dilutable	31.2	31.5	33.1	35.1	35.4	36.8	38.7	41.1	43.4
Total	31.2	31.5	33.1	35.1	35.4	36.8	38.7	41.1	43.4

NAVIGATOR 5000/6000I									
	20 m	21 m	24 m	27 m	28 m	30 m	33 m	36 m	39 m
9 sections									
Non-dilutable	0.0	0.0	0.0	0.0	0.0	0.0	0.0	0.0	0.0
Dilutable	32.3	32.6	34.2	36.2	36.5	37.9	39.8	42.2	44.5
Total	32.3	32.6	34.2	36.2	36.5	37.9	39.8	42.2	44.5

The maximum allowed technical residue is:

Model	Maximum Residue Volume in litres
NAVIGATOR 6000I - 24 m	78

When cleaning the sprayer

- Immediately dilute the residues in the tank in a ratio of 1:10 with clean water. Afterwards spray out on the crop just sprayed with increased driving speed.
- In addition, separately rinse the pump, piping and operating unit with water from the RinseTank. However, it is emphasized that the liquid in the spray lines are in unchanged concentration. Therefore, there should be an untreated field area available to spray this liquid out.
- Follow national regulations when disposing chemical residues.

Lubrication

General Info

Always store lubricants clean, dry and cool - preferably at a constant temperature - to avoid contamination from dirt and condensed water. Keep oil filling jugs, hoppers and grease guns clean, and clean the lubricating points thoroughly before lubricating. Avoid skin contact with oil products for longer periods.

Always follow the quality and quantity recommendations. If no quantity recommended, feed the lubricator until new grease becomes visible.





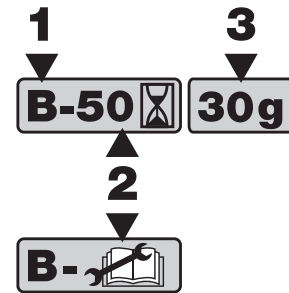

Pictograms in Lubrication & Oiling Plans

1. Lubricant to be used (see "Suitable lubricants" below).
2. Recommended intervals. Shown in hours or with a symbol for occasional maintenance.
3. Quantity to use. Only shown if specifying a quantity.



 **ATTENTION!** Recommended is lubrication of the entire machine, if cleaning the sprayer with a high-pressure washer.

Recommended Lubricants

	What to Lubricate?	Lubricant Type	Factory Use	Suitable Alternatives
	BALL BEARINGS and PUMP	Lithium based grease Consistency NLGI grade 2 Viscosity (@40°C) > 460 cSt	SHELL Gadus S3 V550L 1 Hardi pump grease cartridge (400g): Item no. 28164600	MOBIL grease XHP 462 TOTAL Multis Complex SHD 460
	SLIDE BEARINGS	Lithium based grease Consistency NLGI grade 1/2 Viscosity (@40°C) > 200 cSt	MOBIL XHP 222	SHELL Gadus S3 V220C 2 TOTAL Multis Complex SHD 220
	OIL LUBRICATION POINTS	Engine or transmission oil Viscosity 20W-50 or 80W-90	OK Tractor UTTO GL 4 80W	SHELL Spirax S4 TXM CASTROL ACT EVO 4T MOBIL Mobilube HD 80W/90
	GLIDE SHOES IN BOOM CENTRE	Stearic or a non-greasy type of wax or engine or transmission oil		
	BOLTS	Anti-corrosive wax	PAVA PV 700	TECTYL 506 WD
	VALVES and SEALS (O-RINGS)	NSF 51, NSF 61 silicone compound	ROCOL SAPPHIRE Aqua-Sil	DOW CORNING MOLYKOTE 111 Compound
	HYDRAULIC DAMPING CYLINDER	Hydraulic oil type ISO HVL Wide temperature range DIN 51524-3	CASTROL HYSPIN AWH-M 68	

6 - Maintenance

Grease Nipple

When lubricating the sprayer, please use a grease gun that fit the dimensions of the grease nipples.

Nipple head type: DIN 71412

Nipple head size (A): 6.5 mm



ATTENTION! If grease is leaking from the nipple near its threaded part, when grease is being applied, please tighten the nipple by using a spanner or similar. If damaged or bent out of shape, replace the nipple.



ATTENTION! If applying grease into the nipple seems difficult, unscrew the nipple. Check for blocking inside the nipple, or if the spring-loaded ball is stuck. Clean or repair as needed.



Grease Gun Calibration

Before lubricating the sprayer, you must calibrate your grease gun to ensure applying the correct quantity of grease to each lubrication point. The correct quantity of grease applied will prolong the lifetime of the sprayer.

Calibration Example

1. Insert the correct grease cartridge in your grease gun.
2. Apply grease onto a tissue or a piece of paper. Complete 10 full strokes of the grease gun.
3. Place the paper with grease on a scale (A).
4. If your grease pile weighs e.g. 10 grams, then 1 stroke equals 1gram of grease.

When calibrated, you can count how many strokes to complete, when lubricating different grease points on the sprayer according to the specifications.

Alternative Method

1. Count the strokes, until you have 10 grams of grease piled up on the scale (A).
2. Now you can figure out how many strokes to use for applying a certain amount of grease to a lubrication point.

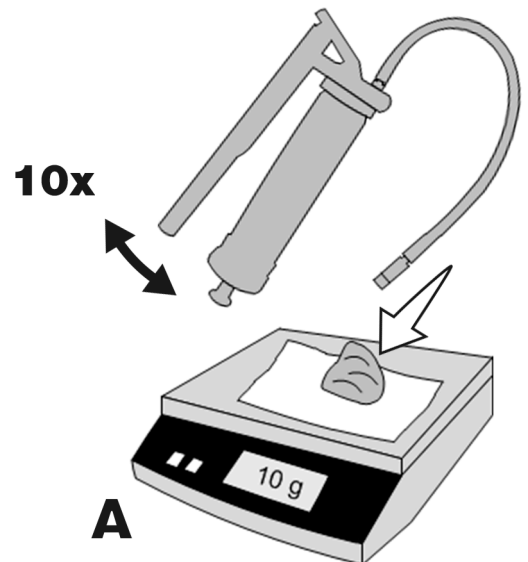

Lubrication Plan - Boom Centre

At the rear of the sprayer, these three points must be greased on both sides of the centre section.

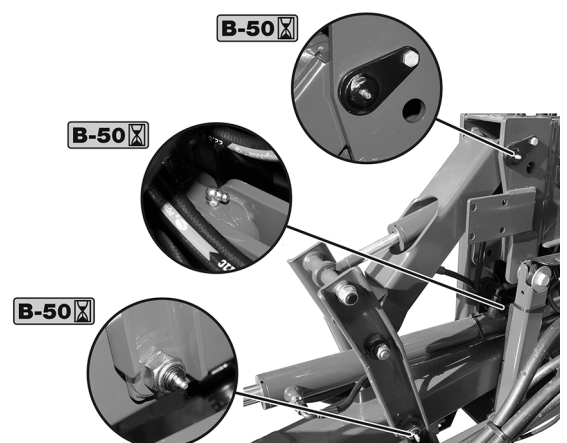

Lubrication and Oiling Plan - Boom Wings

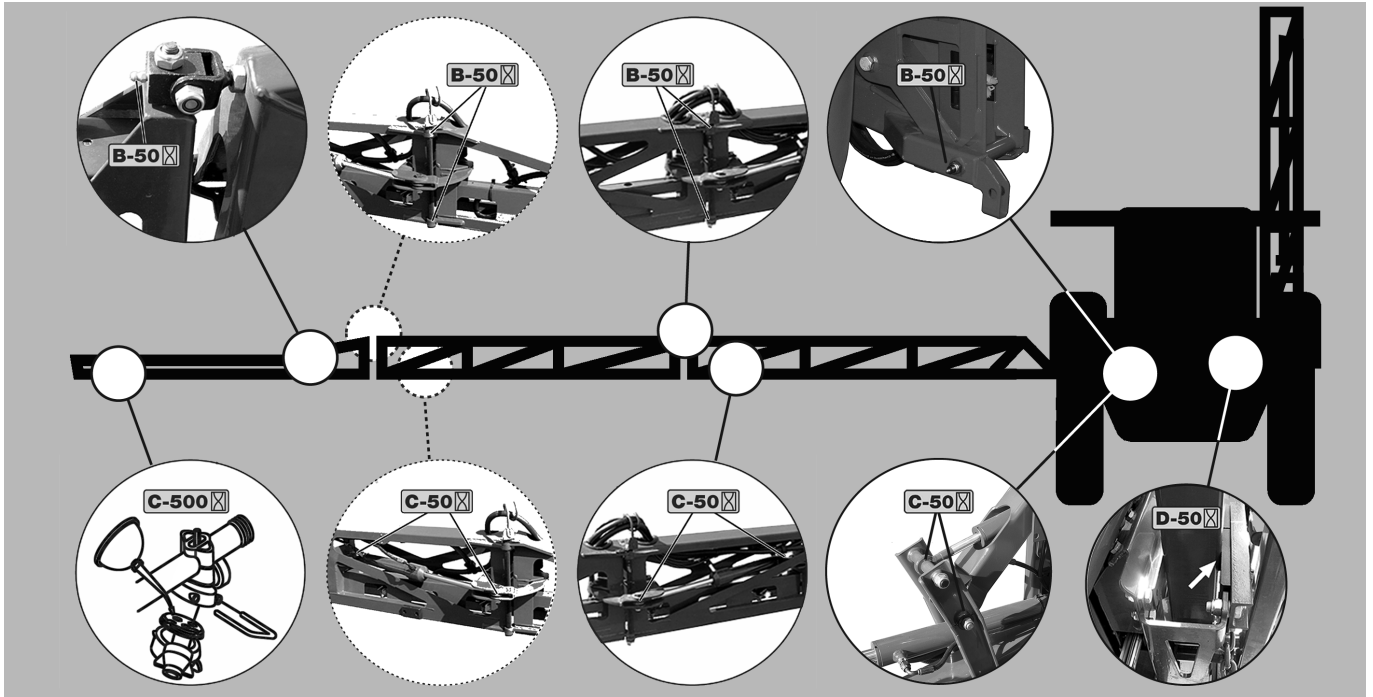

Lubrication Plan - Pump Greasing

Grease the pump as follows:

- Factory greased:
 - 300 g grease into each lubrication point (A).
- Normal operation:
 - Greasing every 50 hours with 30 grams of grease into each lubrication point (A). Also refer to "50 Hours Service - Greasing the Pump" on page 145.
- After disassembling the pump (diaphragm renewal, etc.):
 - The pump must be greased with 200 grams of grease into each lubrication point (A).

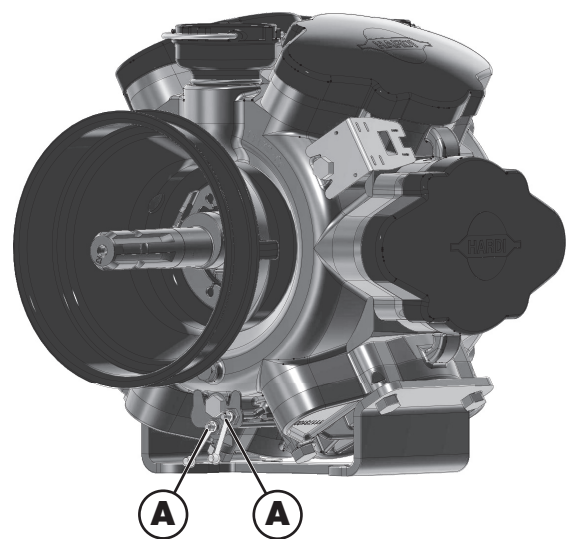

ATTENTION! In order to prevent excessive wear, it is important to use a recommended lubricant! See the section "Recommended Lubricants" on page 131 in this book.



ATTENTION! The pump MUST be stopped during greasing!

6 - Maintenance

Brakes

General Info

Depending on the brake system, it is necessary to maintain your brakes:

General

- "10 Hours Service - Brakes" on page 136
- "1000 Hours Service - "1000 Hours Service - Air compressor" on page 159

Parking Brake

- "250 Hours Service - Parking Brake" on page 152

Hydraulic Brakes

- "250 Hours Service - Adjustment of Wheel Brakes" on page 152
- "250 Hours Service - Hydraulic Brakes" on page 153

Pneumatic Brakes

- "10 Hours Service - Air Tank for Brakes" on page 142 "Daily Service - Air tank" on page 136
- "250 Hours Service - Adjustment of Dual-Line Pneumatic Wheel Brakes" on page 151

Brakes

Maximum wear rates on brake components:

Sprayer Volume	Drum Dimensions	Max. Drum Diameter	Min. Lining Thickness
4000 litres	400 x 80 mm	403 mm	4.0 mm
5000 / 6000/ litres	412 x 160 mm	414 mm	5.5 mm

Pressure settings for the load-apportioning valve for air brakes:

Situation	Pressure in Air Tank
Released	0 bar
Empty main tank	2.8 bar
Half main tank	4.3 bar
Full main tank	Max. pressure (6.5 bar)



DANGER! If exceeding one or more the values, this may cause damage and sudden leaks on the sprayer. Risk of injuries and fatalities.

Scheduled Maintenance

General Info

National or regional laws may require periodic inspection of the sprayers in use. See the following section for more details.

The user may carry out the subsequent periodic service and maintenance work. Contact your HARDI dealer if in doubt. If this work completed correctly, the sprayer will run efficiently and it will prolong its lifetime.

When mentioning a number of hours in this chapter, this means hours of spraying, unless otherwise explained. Read the operation hours in the controller in the tractor (see the instruction book for the controller).

Warranty

For sprayers under warranty the user is obliged to follow the maintenance instructions and fulfil them during the warranty period. Failure to do so, leads to a void warranty and the warranty expires immediately.

Service Intervals

The intervals mentioned here are a summary of the service, that is mentioned in the Lubrication and Scheduled Maintenance parts.

	Repeat intervals						
	Daily	10	50	100	250	500	1000
Hydraulic							
Hydraulic oil level	●						
Hydraulic circuit					●		
Boom and Chassis							
Check the boom	●			●			
Lubricate boom and chassis			●				
Re-tightening the spray boom				●			
Pump							
Lubricate 364 diaphragm pump			□				
Transmission shaft (PTO)			●				
Fluid System							
Inspect spraying circuit		●					
Hoses and tubes					●		
Suction filter		●					
In-line filter		●					
Nozzle filters		●					
Nozzle carousels						●	

● Check

□ Replace/lubricate

6 - Maintenance

Daily Service - Air tank

Drain water from the airtank through the drain valve.



10 Hours Service - Nozzle Filters (If fitted)

The filters are located in the nozzle holder.

Check the filter condition and clean the filter.



NOTE! Refer to Menu 4.1 in the SmartCom controller for specific service interval.

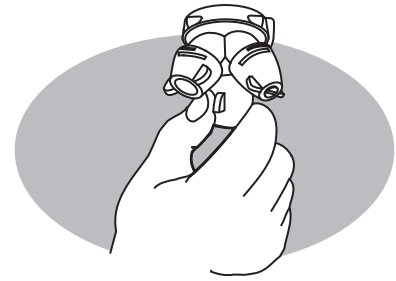

10 Hours Service - Spraying Circuit

Fill with clean water and operate all functions.

Check for leaks using a higher spray pressure than normal.

Check nozzle spray patterns visually using clean water.

10 Hours Service - Brakes

Apply the brake pedal and check the function of trailer the brakes.

10 Hours Service - EasyCleanFilter

This filter has a clogging indicator, but even if this indicator does not show clogging, the filter mostly needs cleaning every 10 hours.

 NOTE! The controller will show a service interval message, when it is time for cleaning the filter.

 WARNING! Always wear protective clothing and gloves before servicing the filter!

 ATTENTION! If you have difficulties with opening the filter, there is another way to handle it.

See "Emergency Operation - EasyCleanFilter" on page 196.

Servicing the Filter

1. Turn the filter lid counter-clockwise to open it as shown in the example. Remove lid and filter from the filter housing.
2. Separate filter element from lid/filter guide by turning locks (A) outwards.
3. Clean filter and if necessary clean the housing for larger impurities.

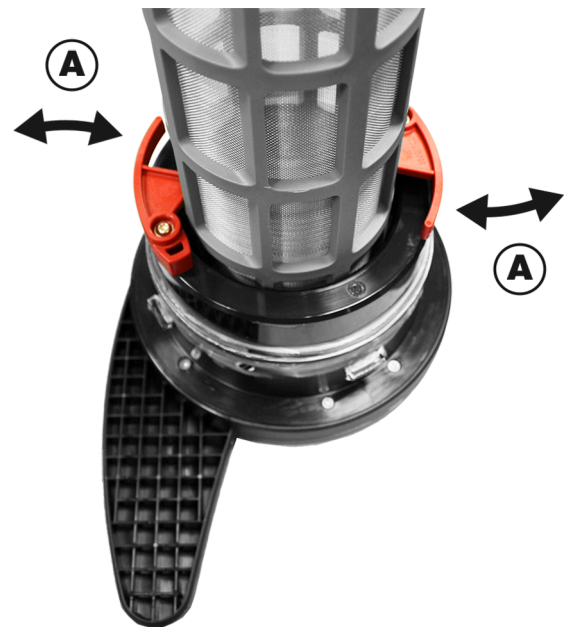

To Reassemble

1. Grease the O-ring on the filter lid.
2. Press the filter onto the filter guide/lid. Make sure that it has caught the guide. Locks (A) are turned inwards.
3. Reassemble filter/filter lid into the housing. Make sure that it has caught the guide in the bottom of the housing.
4. Turn the filter lid clockwise to close it.

 ATTENTION! To be sure that the integrated ball valve has been turned correctly, please observe the emergency handle in the bottom of the filter: When the filter is closed, the handle should be parallel with the hoses in the bottom (as in the example in the picture).

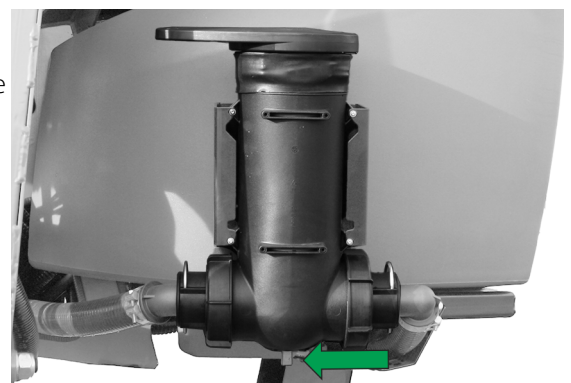

6 - Maintenance

10 Hours Service - CycloneFilter

The standard filter size is 80 mesh and can be changed by opening the filter top.

Servicing the Filter

1. Turn the pressure SmartValve towards .
2. Unscrew the filter lid (A).
3. Lift lid and filter (B) out of the housing.
4. Turn the two locks (C) outwards to unlock the filter from the lid.
5. Separate the filter from the integrated filter guide in the lid.
6. Clean the filter.

To Reassemble

1. Check condition of the two O-rings on the lid/filter guide and lubricate if necessary, or replace them if damaged, before reassembly. Due to small space at the lid, use a paintbrush to apply the grease.
2. Fit the filter onto the recess (do not grease the recess) in the lid/filter guide.
3. Turn the two locks (C) inwards to lock the filter into position.
4. Place the filter/filter lid into the housing and screw the lid, until it hits the stop.

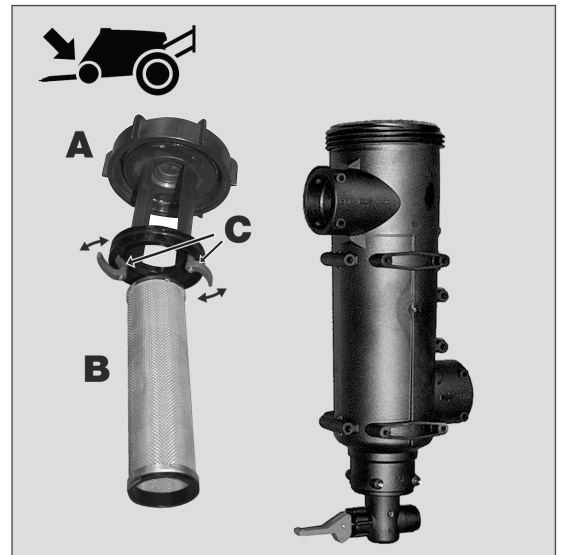

WARNING! Always wear protective clothing and gloves, before servicing the filter!



DANGER! Always turn the pressure SmartValve to , before opening the CycloneFilter!
Otherwise, spraying liquid may hit you when opening the filter and this will also drain the MainTank!



DANGER! Never open the CycloneFilter unless the suction SmartValve is turned to the unused position, and the pressure SmartValve is set to "MainTank".

Otherwise, there is a risk of liquid squirting out when the filter is opened, which will drain the MainTank!

10 Hours Service - In-Line Filter

If the boom is equipped with In-Line filters, unscrew the filter bowl to inspect and clean the filter. When reassembling, the O-ring should be greased.

Alternative filter meshes are available. See the section "Filters" on page 56.



WARNING! Be careful not to splash out liquid, when unscrewing the filter bowl.

Always wear protective clothing and gloves, before servicing the filter!

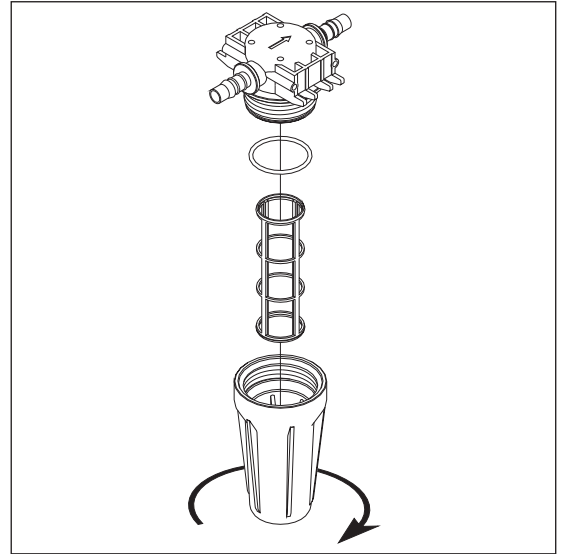

6 - Maintenance

10 Hours Service - Suction Filter for Ace pump (Optional)

1. Unscrew filter housing.
2. Remove mesh screen.
3. Wash with clean water (use a soft brush if needed)
4. Refit and tighten evenly

Check for:

- Mesh not torn or stretched.

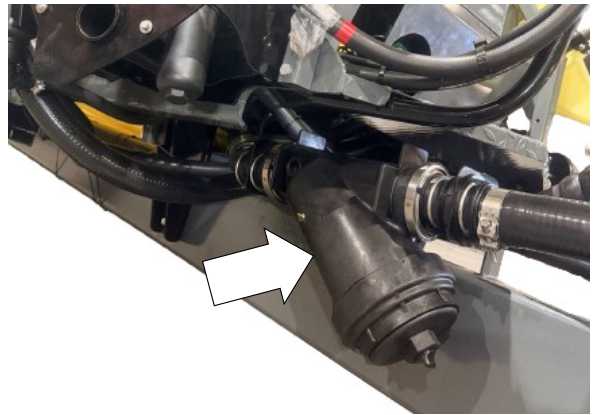

10 Hours Service - Air compressor

1. Check and maintain the oil level at centre of sight glass (1), add oil through the fill cap (2) as necessary.
2. The area surrounding the compressor should be kept clear of chaff and debris.
3. The air intakes should be clean and free from obstructions.



NOTE! Check for unusual noise or vibration.

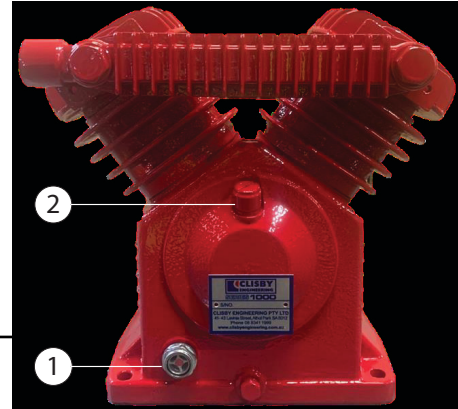

10 Hours Service - Pre cleaner

When dirt reaches the level of the arrow, remove top nut and plastic body, then empty.

1. Regular attention should be given to the maintenance of the air cleaner depending on the operating conditions.
2. The outer air cleaner cartridge is to be removed and cleaned using low pressure air.



WARNING! Do not remove the inner air cleaner cartridge or damage to the air compressor may occur.



6 - Maintenance

10 Hours Service - Ace Pump

Daily inspection

1. Decontaminate and flush the pump after each use to prevent corrosion.
2. If a danger of freezing exists, drain all water from the pump casing by removing the lowest volute pipe plug. This will prevent casting breakage due to frozen liquid inside the pump.

i NOTE! Do not drain the barrier fluid from the seal reservoir.

10 Hours Service - Ace pump

Check and adjust seal reservoir pressure

The reservoir pressure gauge (2) gives a direct pressure reading. Pressure should remain within the green zone during operation. The recommended cold reservoir pressure is 25 to 30 psi.

i NOTE! Pressure will increase during operation as the fluid is heated.

Steps to pressurize the seal reservoir:

1. Verify that fill and drain plugs are installed and tight.
2. Remove air valve cap (1).
3. Add air until gauge reads 25 to 30 psi. An air supply or tank regulated to 30 psi (2 bar) is best.

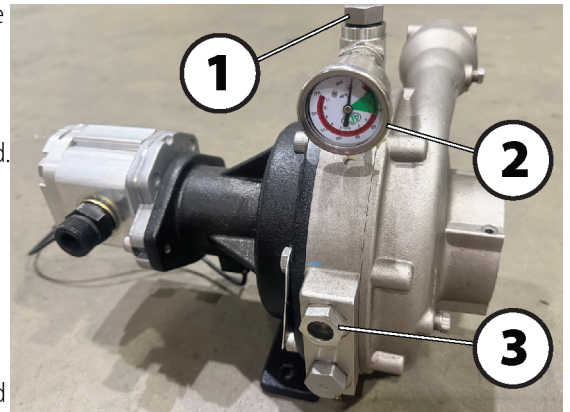

⚠ WARNING! Do not over pressurize. Relieve excess air pressure if necessary.

4. Replace air valve cap.

i NOTE! If air must be added regularly, spray soapy water around plugs, seams and fittings of seal plate to check for leakage. Reseal as needed. If no external leak is found, installation of a seal kit should be scheduled for next machine downtime.

10 Hours Service - Spraying Circuit

Fill with clean water and operate all functions.

Check for leaks by regulating the spray pressure up to 10 Bar.

Check nozzle spray patterns visually using clean water.

10 Hours Service - Brakes

Apply the brake pedal and check the function of the trailer brakes.

50 Hours First Service ONLY - Hydraulic Filter

1. Unscrew filter housing.
2. Remove mesh screen.
3. Wash with clean water (use a soft brush if needed).
4. Replace the filter element.
5. Refit and tighten evenly.

Check for:

Mesh not torn or stretched.



NOTE! Routine service: Every 250 hours



50 Hours First Service ONLY - PWM Filter (for ACE pump)

1. Unscrew filter housing.
2. Remove mesh screen.
3. Wash with clean water (use a soft brush if needed).
4. Replace the filter element.
5. Refit and tighten evenly.

Check for:

Mesh not torn or stretched.



NOTE! Routine service: Every 250 hours

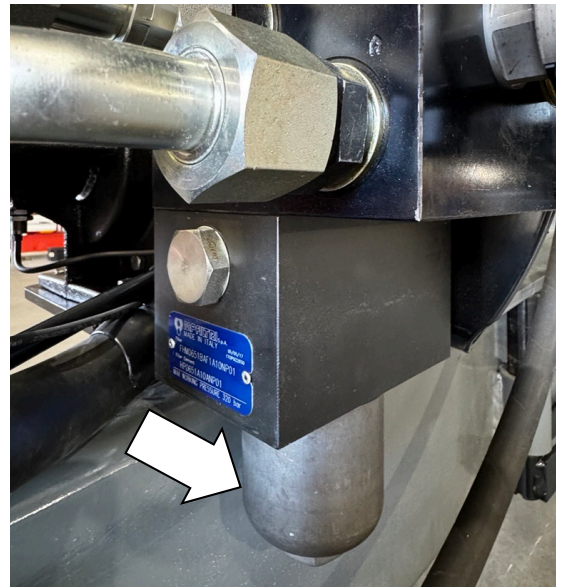

50 Hours Service - Air compressor

1. Check and clean the air filters. A clogged air filter can seriously affect the efficiency of the compressor and cause overheating and high oil usage. Change if necessary.
2. Clean all external parts of the compressor. A dirty compressor will cause abnormally high discharge temperature and resulting oil carbonisation on internal valve components.

50 Hours First Service ONLY - Air compressor

Change the compressor oil after the first 50 Hours.

6 - Maintenance

50 Hours Service - Ace pump

Checking the seal reservoir fluid level

View the site gauge window (3) on the side of the seal reservoir. A float is included to easily see fluid level.

If the fluid is not visible, add fluid by following these steps:

1. Relieve reservoir air pressure by removing air valve cap(1) and depressing the stem.
2. Remove fill plug on top of seal reservoir.
3. Add barrier fluid (Hardi Part: 29004303) until the level is at top edge of site window.



WARNING! Do not overfill.

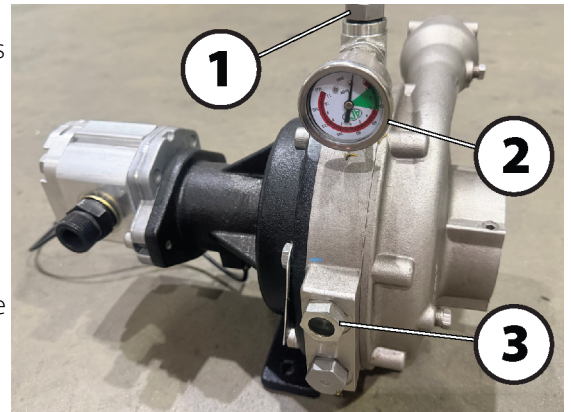

4. Replace fill plug and recharge the air pressure. See "10 Hours Service - Ace pump" on page 142



NOTE: A small amount of barrier fluid will be consumed under normal operating conditions. If the barrier fluid appears cloudy or discoloured in site gauge, drain until fluid runs clear, refill with clean fluid and recharge pressure. Check again in 50 hours. If fluid is cloudy or discoloured again, this is an indication of inboard seal leakage. A seal kit installation should be scheduled for next machine downtime.

50 Hours Service - Greasing the Pump

Grease is necessary every 50 hours with 30 grams of grease into each lubrication point, when operating the pump.

Also refer to "Lubrication Plan - Pump Greasing" on page 139.



ATTENTION! In order to avoid excessive wear, it is important to use a recommended lubricant! Refer to "Suitable Lubricants" on page 137 for more information.



ATTENTION! When greasing the pump MUST be stopped!

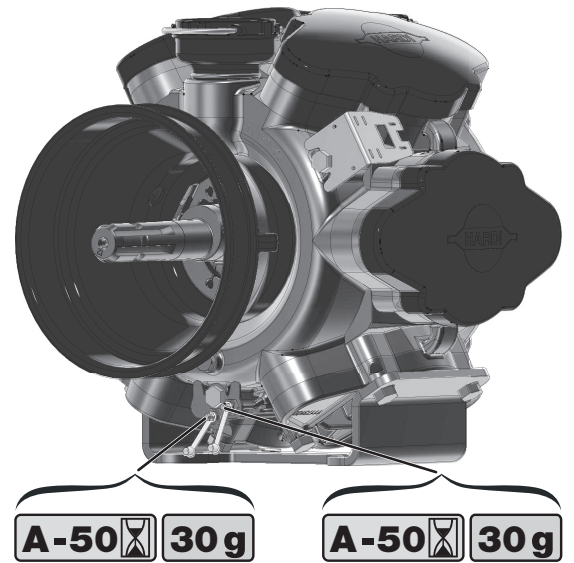

6 - Maintenance

50 Hours Service - Transmission Shaft (PTO)

1. Check function and condition of the transmission shaft protection guard. Replace any damaged parts.
2. Grease the lubrication points.



The grease points, type and amount of grease to apply shown in the pictures below together with the intervals.

The amount of grease to be applied is mentioned in grams (g).

i NOTE! Test your grease gun to see how many grams it supply, for example after 5 strokes.

ATTENTION! It is important to apply the correct amount of grease at the intervals. Too little or too much grease will shorten the lifetime of the PTO.

Standard PTO for Tractor and Sprayer

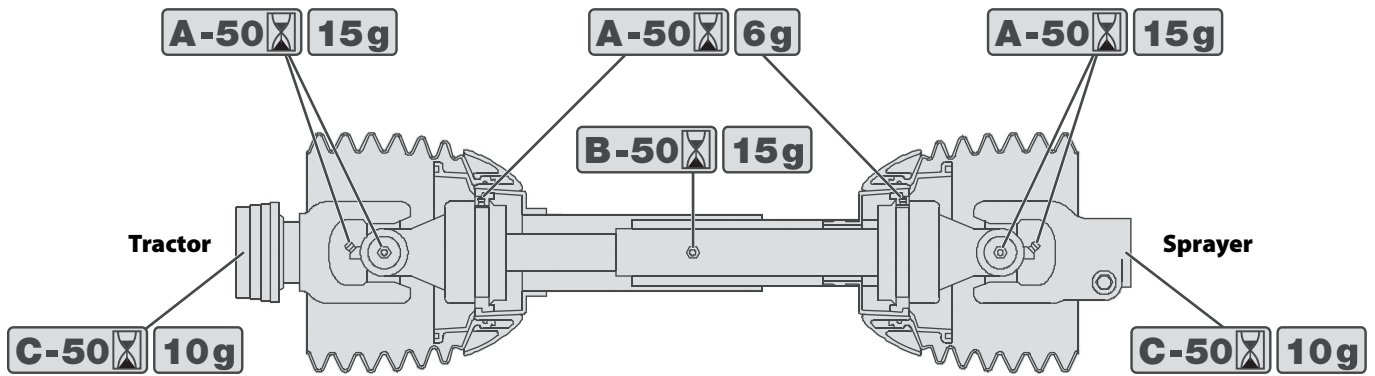

Wide Angle PTO for Tractor, Standard PTO for Sprayer

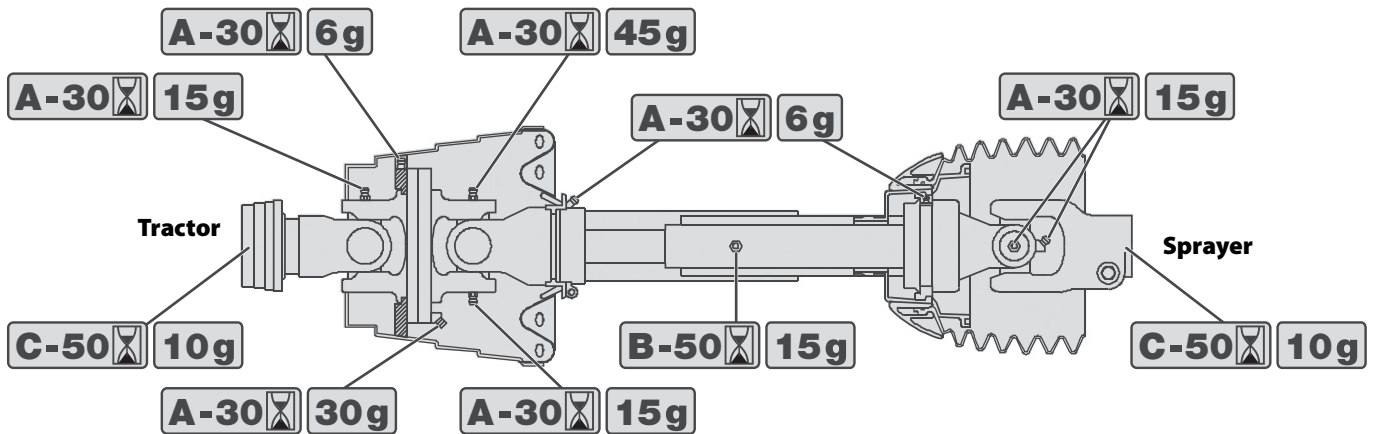

Wide Angle PTO for both Tractor and Sprayer

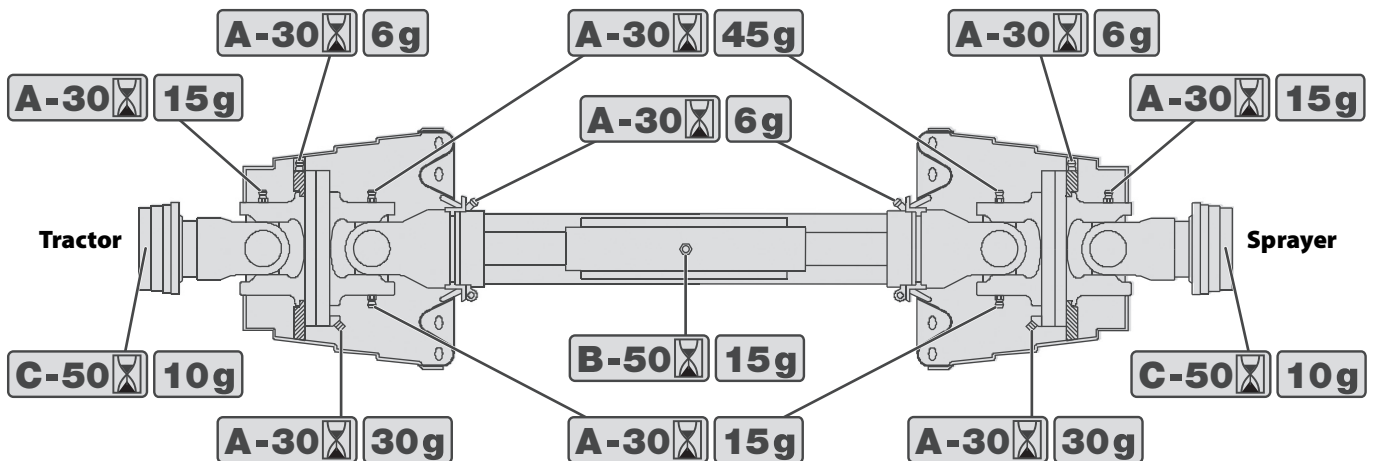

50 Hours Service - Wheel Nuts

Tighten wheel nuts as follows.

Mounting wheel hub to rim plate: Torque 490 Nm.

Tightening sequence for wheel nuts: See illustration and tighten in the numbered order.



ATTENTION! Always refit the plastic nut covers on the nuts after the wheels have been mounted or re-tightened.

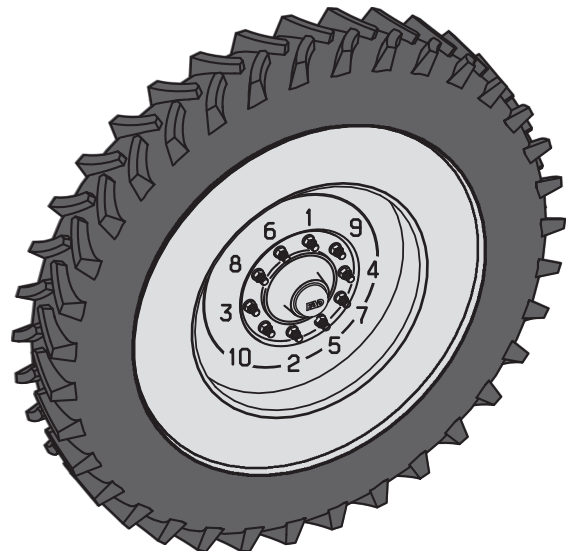
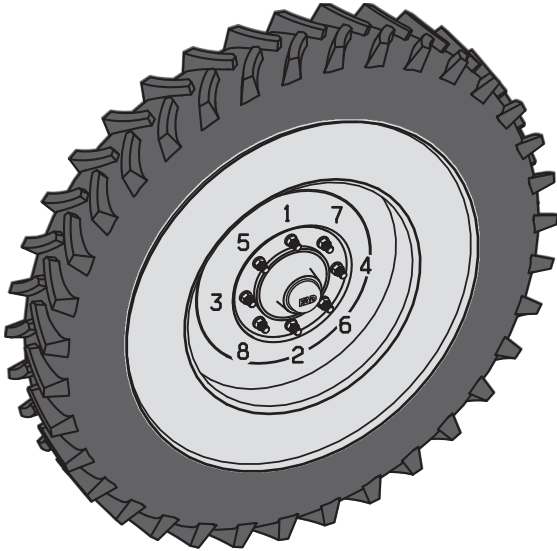

50 Hours Service - Tyre Pressure

Check the tyre pressure according to the table in "Tyre Pressure" on page 205.



DANGER! Never inflate tyres more than to the pressure specified in the table. Over-inflated tyres can explode and cause severe injuries!



WARNING! If renewing tyres, always use tyres with minimum load index as specified. See "Tyre Pressure" on page 205.



6 - Maintenance

100 Hours Service - Air Filter/Lubricator

i NOTE! Only fitted on ActiveAir Fluid System.

Drain the Filter

There are 2 possibilities to drain the bowl:

- Open the drain:
 1. Push the knob (A) to open the valve.
 2. Drain the air bowl.

i NOTE! The drain can be operated when the bowl is under pressure.

- Remove the air bowl for draining:
 1. Close the ball valve located near the air filter.

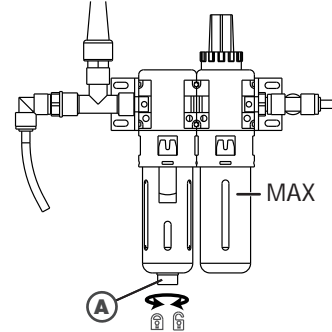

2. Slightly open the oil bowl (B) by turning counter-clockwise to let the air pressure escape the bowl.
3. Turn clockwise to refit and lock the oil bowl (B).
4. Turn counter-clockwise 1/8 turn to remove the protective bowl (C).
5. Turn counter-clockwise 1/8 turn to remove the air bowl.
6. Pour out water from the air bowl.
7. Place the air bowl into the protective bowl.
8. Refit the bowls on the filter body.
9. Turn clockwise 1/8 turn to lock.
10. Open the ball valve.

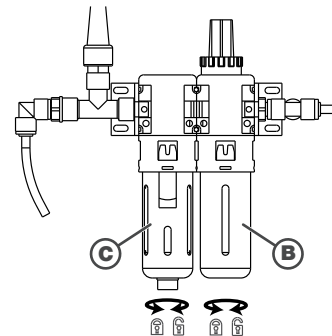

i NOTE! Depressurise the air circuit before dismantling the air bowl.

100 Hours Service - Re-tightening the Spray Boom

Due to several movements of the spray boom from driving in the field with an unfolded boom, you must re-tighten all bolted connections on the boom centre and boom wings.

Where you find bolts with Nord-Lock washers, please tighten with the following torques.

Bolt Size	Torque (Nm)
M10	50
M12	85
M14	136
M16	208
M18	291
M20	408
M22	557
M24	703
M27	703
M30	703

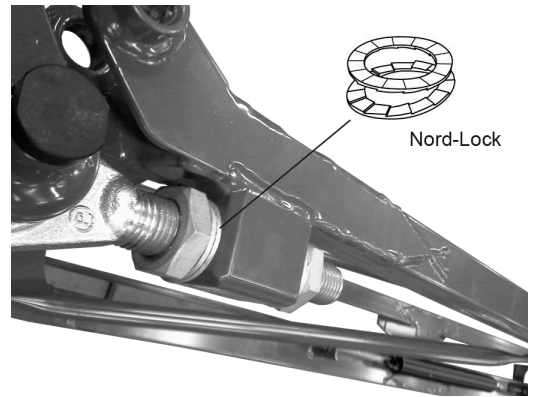

6 - Maintenance

100 Hours Service - Hydraulic Motor for Pump

Check the coupling parts.

1. Remove the lid by unscrewing the two bolts in the sides.

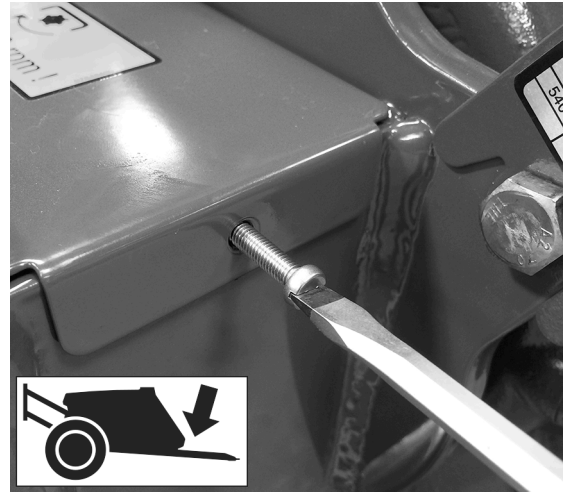

2. Check the condition of the rubber parts (A) in between the steel claws (B). If the rubber parts are worn away, the motor will be noisy when rotating, and the steel parts will wear out quickly.

In this case worn parts needs to be replaced, as follows.

3. Remove the hydraulic motor retaining bolts (C).
4. Lift away the hydraulic motor.
5. Replace the rubber part.
6. Refit the hydraulic motor so that the rubber and claw parts locate in position, as in the picture.
7. Refit the retaining bolts (C).
8. Put the lid back on and mount the bolts.

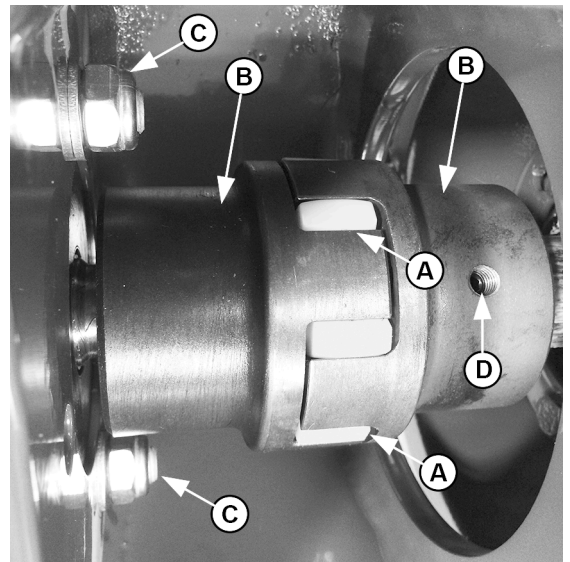

NOTE! Loosening the grub screws (D) is only necessary if realigning the claw parts.

250 Hours Service - Hydraulic Circuit

Check the hydraulic circuit for leaks. Repair if needed.

Refill following nitrogen accumulators:

- ParaLift suspension (if fitted)
- Wheel axle suspension (if fitted)
- Yaw suspension (if fitted)



WARNING! Nitrogen accumulators may contain oil under pressure.

250 Hours Service - Hoses and Tubes

Check all hoses and tubes for possible damage and proper attachment. Replace damaged hoses or tubes.

In general, always replace a hose or tube if:

- It is leaking.
- Reinforcement material inside the hose is visible due to cracks in the outer layers.

6 - Maintenance

250 Hours Service - Adjustment of Wheel Brakes

1. Jack up the rear of the sprayer from the ground and support with axle stands placed under the wheel axle.

Make sure the sprayer is stable and secured before carrying out any adjustments.



ATTENTION! There are two versions of the parking brake system available, one of the pictures should show your system at hand.

2. Loosen the hand brake cable at the rigging screw below the sprayer.
3. Loosen the 4 bolts at the brake connector (C) between the brake arms. Also loosen the screw (B) in each end of the brake connector.
4. Adjust the nut (A) counter-clockwise. This moves the brake arm backwards. Turn the nut 60° (1/6 turn) at a time - alternate between left and right brake.
Continue the adjustment, until resistance occurs when rotating the hub/wheel by hand (difficult to turn the wheel by hand).
5. Turn the nut 60° (1/6 turn) clockwise to loosen brake. Hub/wheel should rotate freely now.
6. Tighten the brake connector (C) bolts again.
7. Adjust the parking brake cable again.

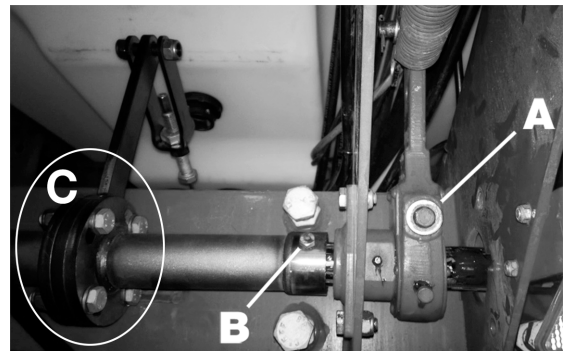
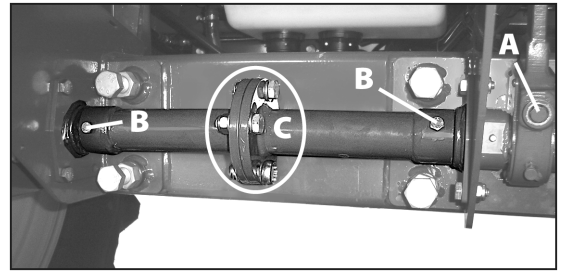

250 Hours Service - Wheel Bearings

Check for play in the wheel bearings:

1. Place chocks in front of and behind the left wheel and jack up the right wheel.
2. Support the trailer with axle stands or strong trestles.
3. Rock the right wheel to discover possible play in the bearings.
4. If any play, support the wheel axle to prevent the trailer from falling down from the jack.
5. Remove hub cap (A) and cotter pin (B). Turn the wheel and tighten the castle nut (C), until feeling a slight resistance in the wheel rotation.
6. Loosen the castellated nut until the first horizontal or vertical notch aligns with the cotter pin hole in the shaft.
7. Fit a new cotter pin and bend it to keep it in place.
8. Fit the hub cap to the hub again.
9. Repeat the procedure for the left wheel.

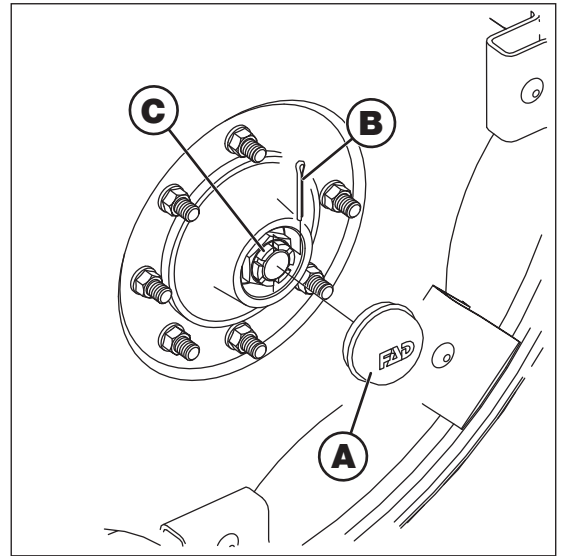

250 Hours Service - Parking Brake

Inspect the following:

Parking Brake Lever

If pulling further backwards than 90° (midway) is possible, using a traction of approximately 25 kg, the cable needs adjustment.

Parking Brake Cable

Inspect the parking brake cables for possible wear or damage. Replace worn or damaged parts.

When the parking brake is relieved, the cable must be limp; otherwise, it needs adjustment.

Correct Length

- When the brake is relieved, the cable must be tight, but not stretched.
- Carry out lengthening/shortening of the parking brake cable by adjusting the rigging screw located inside the frame.

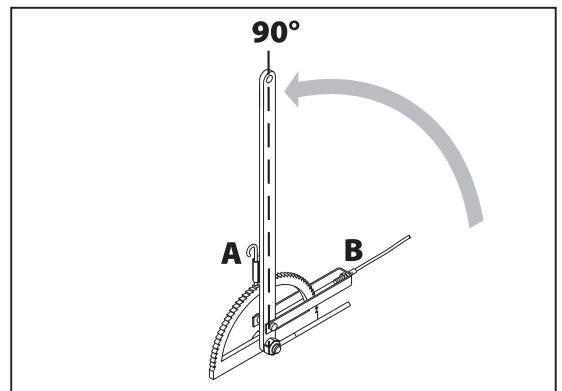

250 Hours Service - Hydraulic Brakes

Apply brakes to full pressure and inspect brake lines for damage or leaks. Replace damaged parts.

If dismantling the hydraulic brake lines, always vent the hydraulic circuit afterwards:

1. Have a helper to apply the brake.
2. Loosen the brake hose at the left brake cylinder.
3. The helper may continue applying the brake, until brake fluid without air bubbles comes out.
4. Tighten the brake hose, before relieving the brake again.
5. Repeat step 1-4 to vent the right brake cylinder.



WARNING! If dismantling the hydraulic brake lines, always vent the hydraulic circuit afterwards.

6 - Maintenance

250 Hours Service - Air compressor

1. Inspect the entire system for air leaks, check that the sump breather hose is clear and not kinked to vent excessive pressure.
 2. Inspect for oil contamination or degradation and change if necessary.
-

250 Hours Service - Hydraulic Filter

1. Unscrew filter housing.
2. Remove mesh screen.
3. Wash with clean water (use a soft brush if needed).
4. Replace the filter element.
5. Refit and tighten evenly.

Check for:

Mesh not torn or stretched.



250 Hours Service - PWM Filter (for ACE pump)

1. Unscrew filter housing.
2. Remove mesh screen.
3. Wash with clean water (use a soft brush if needed).
4. Replace the filter element.
5. Refit and tighten evenly.

Check for:

Mesh not torn or stretched.

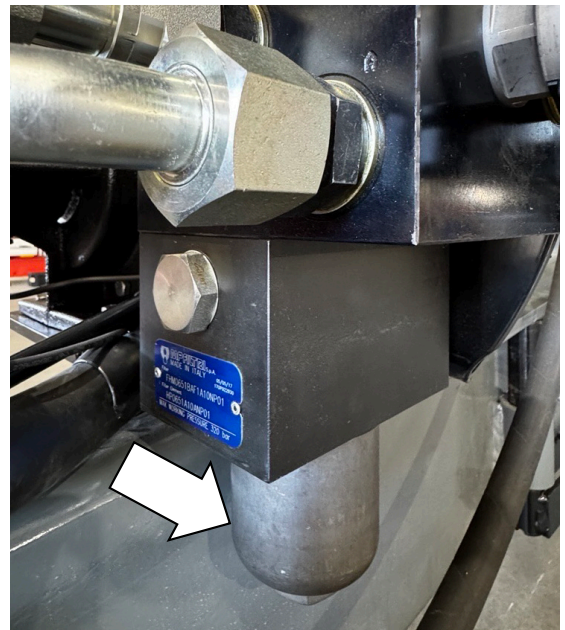

250 Hours Service - Retightening the Chassis

The chassis consists of two sections bolted together. Also the drawbar is bolted to the chassis. These bolts need to be tightened correctly. Check regularly if the bolts are tightened according to the specified torques below.

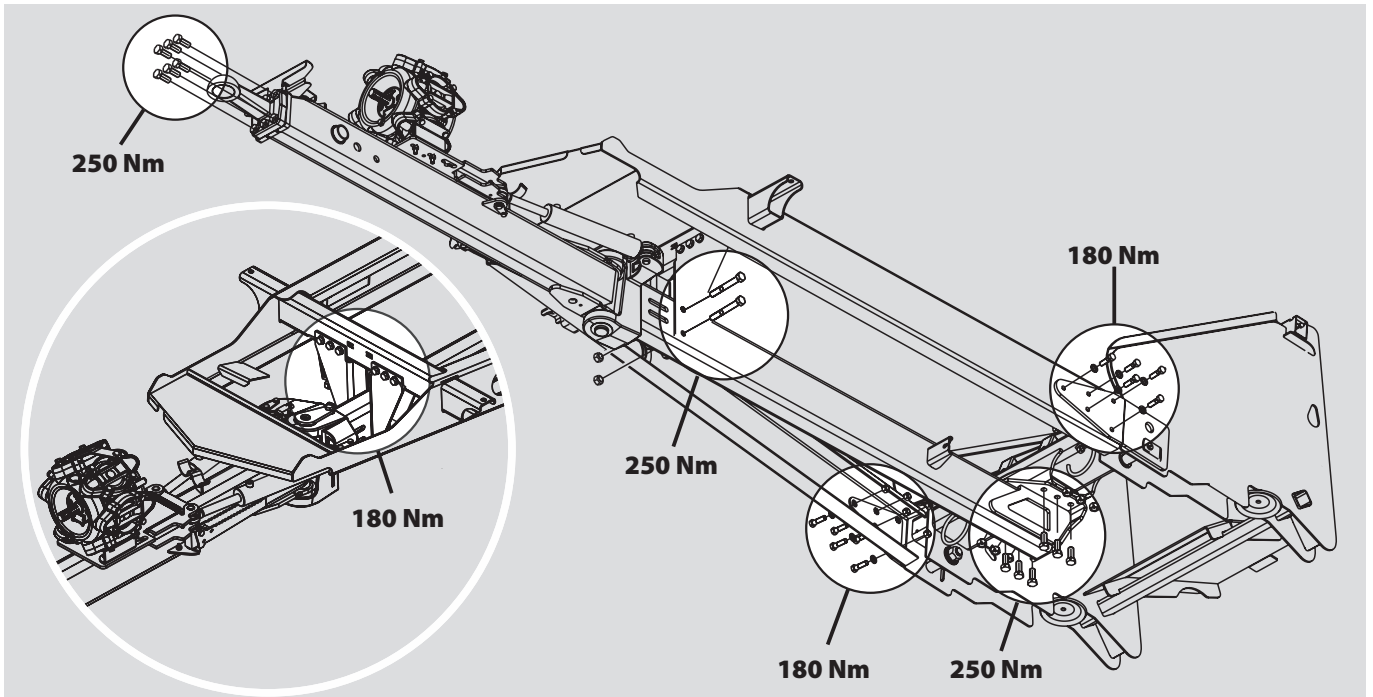

*EU model is shown with steering drawbar.

6 - Maintenance

500 Hours Service - Replacing the Filter Element in the Air Filter/Lubricator

i NOTE! Only fitted on ActiveAir Fluid System.

1. Close the ball valve located before the air filter.
2. Slightly open the oil bowl (A) by turning counter-clockwise to let the air pressure escape the bowl.
3. Turn clockwise to refit and lock the oil bowl (A).
4. Turn counter-clockwise 1/8 turn to remove the protective bowl (B).
5. Turn counter-clockwise 1/8 turn to remove the air bowl.

i NOTE! Depressurise the air circuit before dismantling the air bowl.

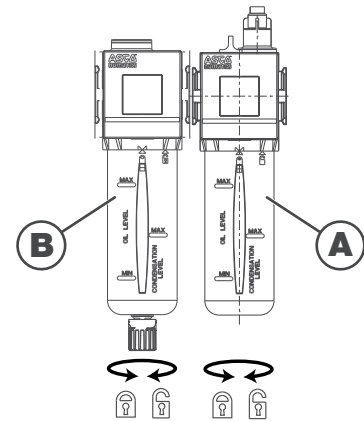

6. Unscrew the retaining screw (C) and remove the filter (D).
7. Fit a new filter element and lock with the retaining screw (C).
8. Place the air bowl into the protective bowl (B).
9. Refit the bowls (B) on the filter body.
10. Turn clockwise 1/8 turn to lock.

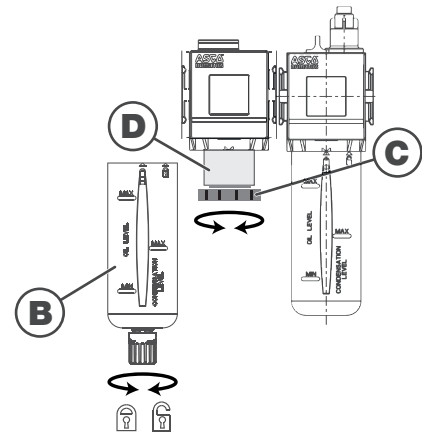

1000 Hours Service - Wheel Bearings and Brakes

Check the condition of the bearings and brake wear parts in the following way:

1. Place brake chocks in front of and behind the left wheel. To service, jack up the right wheel.
2. Support the trailer with axle stands.
3. Remove the wheel.
4. Unscrew the 6 bolts and remove the hub cap (A), cotter pin (B) and castle nut (C).
5. Pull off the brake drum (D). Use a wheel puller if necessary.
6. Vacuum the brake drum (D) for brake dust, or rinse it with water.

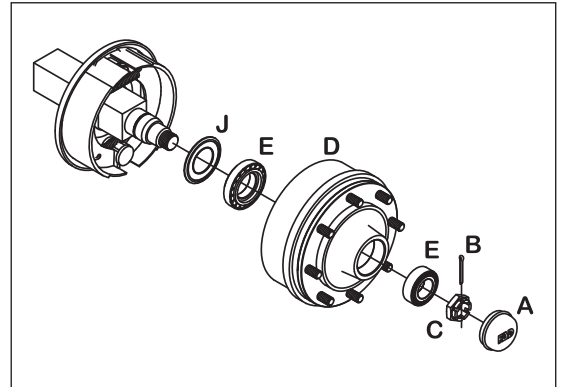

⚠ DANGER! Brake dust can cause severe health injuries! Avoid inhalation of brake dust! Wear a dust mask when servicing the brakes. Do not clean brakes with compressed air! Use a vacuum cleaner or rinse with water to avoid blowing brake dust around.

7. Rinse the remaining parts on the brake carrier plate with water and wipe them off.
8. Remove roller bearings (E), clean all parts with a degrease detergent and wipe them.
9. Check the brake drum diameter (K) and lining thickness (L). Replace if worn.

Max. wear rates on brake components:

- Max. drum diameter (K): 302 mm (Small drums)
- Min. lining thickness (L): 2.0 mm

⚠ WARNING! Never exceed the specified minimum lining thickness (L) is the absolute minimum. Replace the parts, if they would reach the above dimensions before the next service inspection.

⚠ WARNING! It is necessary to renew brake linings or brake drums for both sides at the same time.

⚠ ATTENTION! If removing the brake drum from the wheel hub, a hydraulic press is required to press the wheel studs out.

10. Remove the clevis pin between the air diaphragm cylinder and the brake cam lever.
11. Remove the cotter pin (G), castle nut (F) and the brake shoe anchor bolt (H), and slide the brake shoes over the cam. Twist the pair of brake shoes to remove the shoe return springs (I). If the linings are worn, replace the brake shoes.
12. Apply a small amount of copper paste on moving parts, reassemble the brake shoes, and shoe return springs (I).

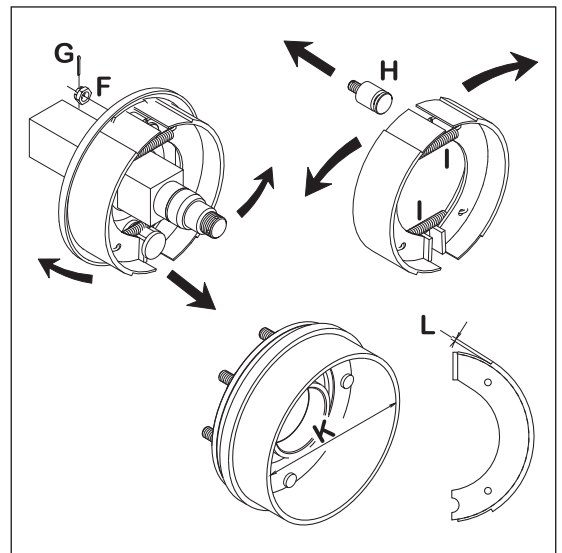

⚠ WARNING! Do not get copper paste in contact with the brake linings and drums.

13. Fit the shoe assembly with the anchor bolt (H) first. Then pull the shoes away from each other and slide them over the cam afterwards. Tighten the anchor bolt castle nut (F) again, and fit a new cotter pin (G).
14. Check roller bearings for discolouration and wear. Replace if worn or damaged.
15. Assemble drum (D) and bearings (E) using a new sealing ring (J).
16. Fill the hub and bearings with new grease, before fitting them to the wheel axle.

⚠ WARNING! Do not get oil or grease in contact with the brake linings and drums.

6 - Maintenance

17. Fit the castle nut (C). Rotate the brake drum (D) and tighten the castle nut (C), until a slight rotation resistance is felt.
18. Loosen the castle nut (C) again, until the first notch aligns with the cotter pin hole in the axle.



ATTENTION! The shaft has a vertical and a horizontal cotter pin hole. Use the one first aligned with the notch when loosening the castle nut.

19. Fit a new cotter pin (B) and bend it to keep it in place.
20. Fit the hub cap (A) to the hub. Slightly tighten the 6 bolts.
21. Adjust the brakes as described in "250 Hours Service - Adjustment of Wheel Brakes" on page 152.
22. Fit the wheel again and tighten the wheel nuts. See "Tightening Bolts and Nuts" on page 203 regarding torque wrench setting. Tighten all bolts to half the specified torque at first, and then tighten to the specified torque.
23. Tighten again after 10 hours of work. Check the torque every day, until it is stabilised.
24. Repeat the steps for servicing the left wheel. Remember to place chocks on both sides of the right wheel.



WARNING! If you do not feel confident changing wheel bearings or brakes, then contact your local HARDI dealer.

1000 Hours Service - Ace pump

Seal reservoir fluid change

1. Remove drain plug (1) and drain barrier fluid from the reservoir into a clean bucket.
2. If the fluid is clear, reinstall plug, refill with new barrier fluid and recharge air pressure.
3. If the fluid is cloudy, discoloured or contains water, this could be the indication that a seal leak is developing.
4. Replacement of the seal kit is recommended to ensure trouble free operation for the next season.

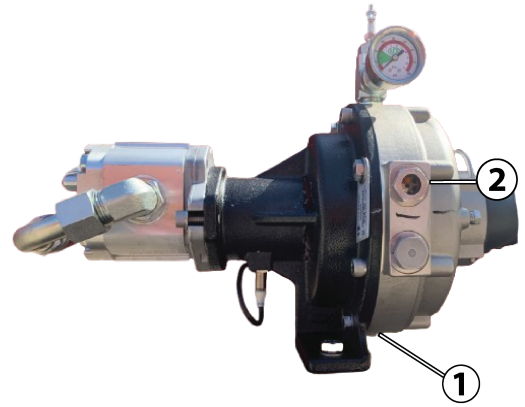

1000 Hours Service - Air compressor

1. Replace compressor oil, oil should remain at centre of sight glass.
2. Replace the air filter.



NOTE! Replacement may be necessary more often under poor operating conditions.

3. Check the head, cylinder and hold down bolt torque. Bolt torque: 24Nm (18ft-lb).
4. Clean compressor and check for leaks.

6 - Maintenance

Occasional Maintenance

General Info

The maintenance and service intervals for the following components will depend very much on the operating conditions, and therefore it is almost impossible to specify the intervals beforehand.

The operator must select appropriate intervals for the occasional maintenance.

If in doubt, contact your local HARDI dealer.

Lifting and Removing the Pump

When lifting and removing the pump, use a shackle fitted to the built-in lifting eye located between the heads (A).



WARNING! To prevent damages in case of a free-falling pump, use lifting gear and a steel shackle with at least 3.5 tonnes min. tensile strength.



NOTE! Pump weight is approximately 75 kg.

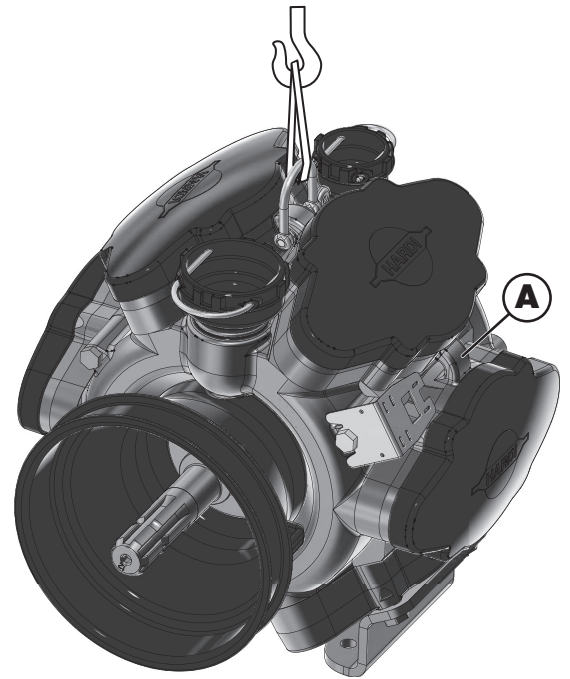

Speed Transducer for the Pump

The speed transducer that measures rotations per minute (RPM), is located at the inner side of the PTO shield.

The sensor is an inductive type, which requires metallic protrusions to pass by it to trigger a signal.

If exchanging the sensor, it must be installed accurately to function properly.

Adjustment

1. Adjust the air gap (A) between sensor tip and the protruding pump part by turning the counter nuts at the support bracket for the sensor.

The air gap (A) must be set to 1 mm (+0.3/-0.0 mm).

Use a feeler gauge or similar tool to verify.

2. Verify transducer function on the controller:
 - SmartCom:
 - Monitor the menu [4.3.5.1.3 Pump RPM].

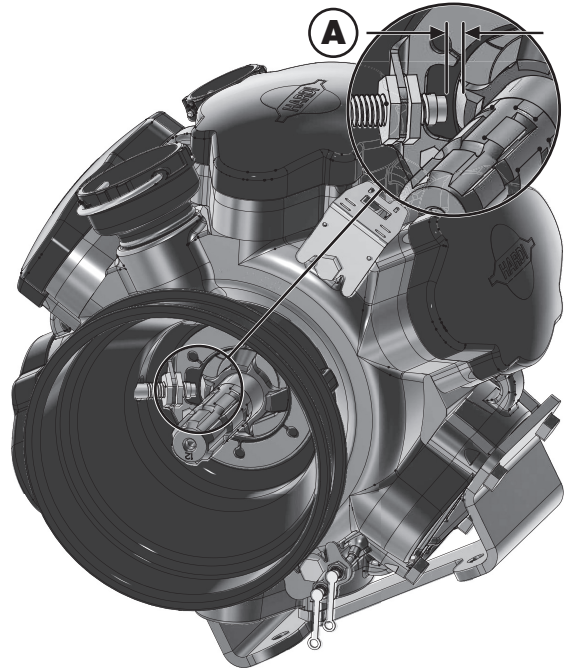

6 - Maintenance

Pump Valves and Diaphragms Renewal

Pump model: 364

1. Lift off the plastic covers (A) with your hands by pulling with the fingertips while pushing with the thumbs in the centre.

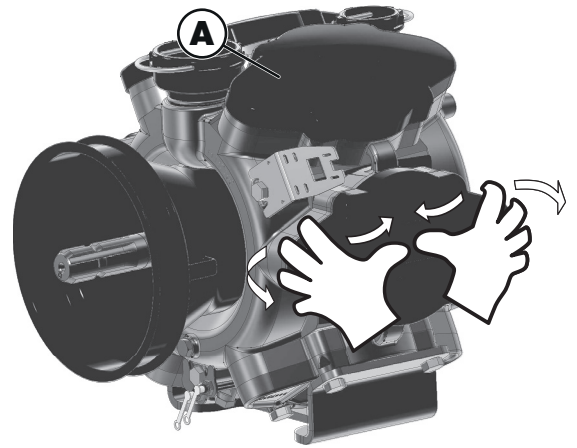

Valve Renewal

2. Loosen the 4 head bolts (B).
3. Remove the head (C).
4. Replace the valves (D) - note their orientation, in order to replace them correctly!

 ATTENTION! Recommended is to use new gaskets (E), when changing or checking the valves.

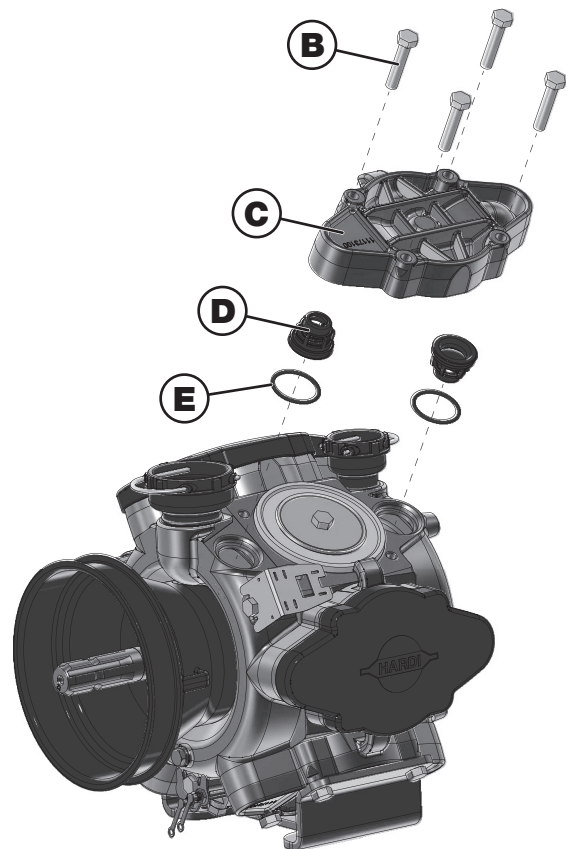

Diaphragm Renewal

5. Loosen the diaphragm bolt (F).
6. Remove the upper diaphragm washer (G).
7. The diaphragm (H) may then be changed.
8. Remove the drain hole bolt (I) and check for dirt blockage in the bottom of the pump.
9. Apply a small amount of pump grease on the lower diaphragm washer surface (J), i.e. between the washer and diaphragm (H).
10. Reassemble the pump with the following torque settings.
 - Diaphragm head bolts (B): 90 Nm.
 - Diaphragm bolt (F): 90 Nm.
 - Drain hole bolt (I): 50 Nm.
11. Refit the plastic covers (A).



ATTENTION! Before tightening the 4 bolts (B) for the head, the diaphragm (H) must be positioned between the centre and top position of the piston stroke, to ensure correct sealing between the pump housing and diaphragm cover (C). Turn the crankshaft to check, if necessary.

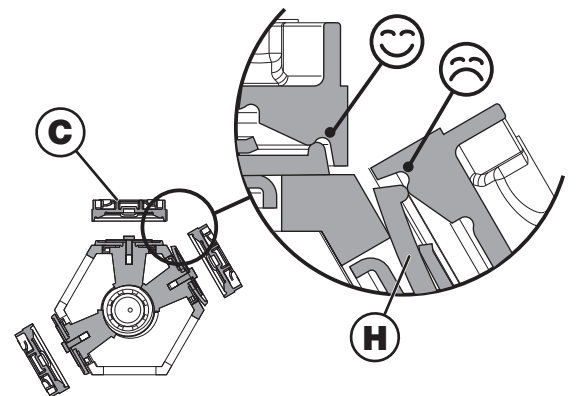
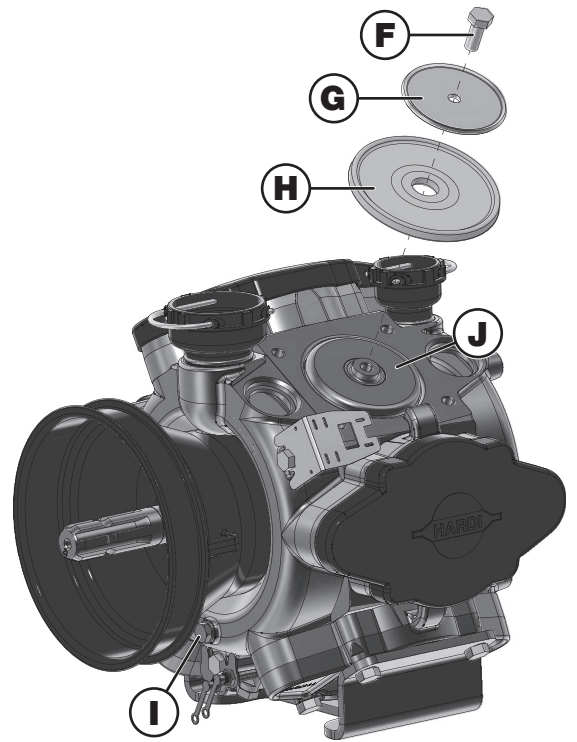

Lubrication after Assembly

After disassembling the pump for diaphragm renewal, etc., you **MUST** lubricate with 200 g grease into each lubrication point.

HARDI pump grease cartridge (400g): HARDI item no. 28164600

Overhaul Kit

Pump model: 364

It is possible to order an overhaul kit for the diaphragm pump (valves, seals, diaphragms etc.). Detect the pump model - order the overhaul kit at the local dealer.

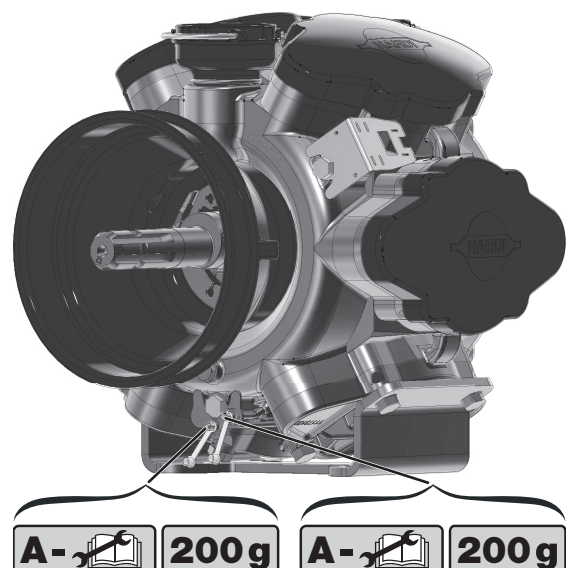











6 - Maintenance

Symbols for Valves

The symbols shown on the spray valve labels designate fluid functions the operator can set.

The labels must be readable when operating the sprayer. Replace damaged or unreadable labels.

The symbols explained below.

Symbol	Symbol Description	Label Colour	HARDI Item Number
	Suction from the MainTank	Black / Blue	97821900
	Suction from the RinseTank	Black / Blue	97822000
	Filling of the MainTank	Black / Green	97810300
	Spraying / Pressurized nozzles	Black / Green	97810400
	Cleaning the inside of the MainTank	Black / Green	97810500
	Agitation in the MainTank	Black / Green	97810900
	TurboFiller	Black / Green	97821500
	Cleaning of empty chemical containers	Black / Yellow	97821600
	Agitation in the TurboFiller	Black / Yellow	97821500
	Suction from the TurboFiller to the MainTank	Black / Yellow	97821400

Safety Valve Activation

To make the fluid system work perfectly over time, it is good practice regularly to provoke opening of the safety valve.

This prevents clogging and ensures proper function of the safety valve. Open the valve by turning the pressure SmartValve to "Pressure draining" or an unused function, when the pump is running. This is good practice for all sprayers; particularly for sprayers without optional equipment.

 **DANGER!** Before turning pressure the SmartValve to "Pressure draining", it is very important to ensure correct and complete fit of the quick coupler lid to the filling stud in its locked position. Failure to do so causes a risk of contamination and injury from the quick coupler lid being "shot" off when pressurized! If it is not possible to fit the lid completely, lubricate the rubber seal and the grip hooks.

Cone Check/Renewal for the Pressure Regulation Valve

If it becomes difficult to build up sufficient pressure or if pressure fluctuations occur, it may be necessary to renew cone and cylinder.

1. Remove 4 screws (A) and remove the housing.
2. Remove 4 screws (B).
3. Replace cylinder (C) and O-ring (D).
4. Loosen the nut (E), remove and replace the cone (F).
5. Reassemble in reverse order.

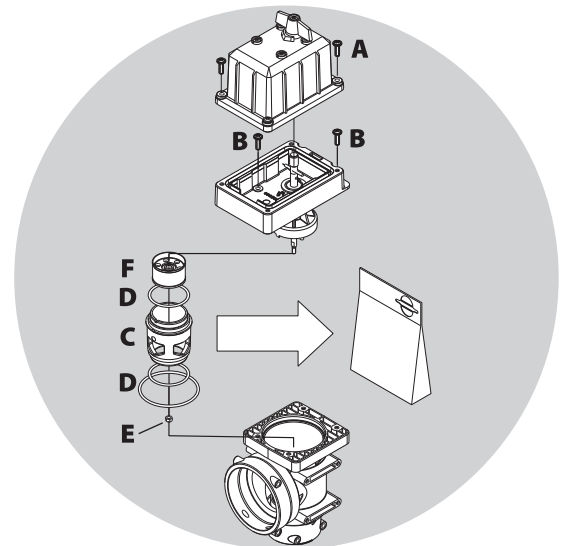

Drain Valve Seal Replacement

If the MainTank drain valve leaks, change the seal and seat in the following way.



DANGER! Do not enter the inside of the tank - it is possible to replace all parts from the outside of the tank!



WARNING! Use eye / face protection mask, when dismantling the tank drain valve!

1. Make sure that the tank is empty and clean.
2. Check that the valve is closed and the string loose.
3. Pull out the clip (A) and pull down the connecting piece (B).
4. Pull out the entire valve assembly.
5. Check cord and valve flap assembly (C) for wear, replace seal (D) and reassemble.
6. Reassemble the valve using a new valve seat (E). Lubricate O-rings (F) before assembly.
7. Fit clip (A) again.

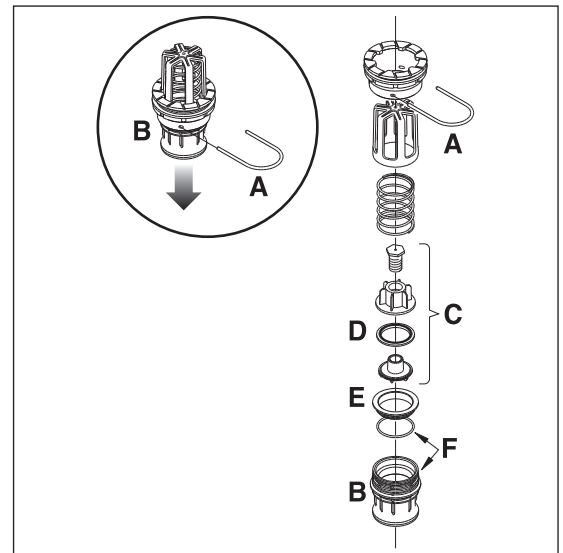

ATTENTION! Check the valve function using clean water, before filling chemicals into the tank.

6 - Maintenance

3-Way Valve Adjustment

The large ball valve used for SmartValves and valves for filling equipment (type s93) can be adjusted, if it is too tight to operate - or if it is too loose (= liquid leakage).

- Correct setting is when possible to operate the valve smoothly by one hand.

Use a suitable tool and adjust the toothed ring inside the valve as shown on the drawing.



ATTENTION! Adjustment not possible for the small ball valves (type s67).

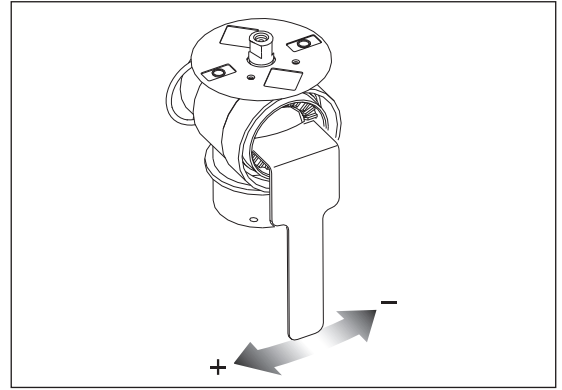

Feed Pipe Clamp Assembly

Remove a feed pipe from the pipe clamps the following way:

1. Use a flat bladed screwdriver to prize the cover off the first corner (A).
2. Hold the clamp top with your hand and prize off the opposite corner (B) with the screwdriver.
3. Prize off the other side of the pipe clamp with the screwdriver.
4. Take out the feed pipe.

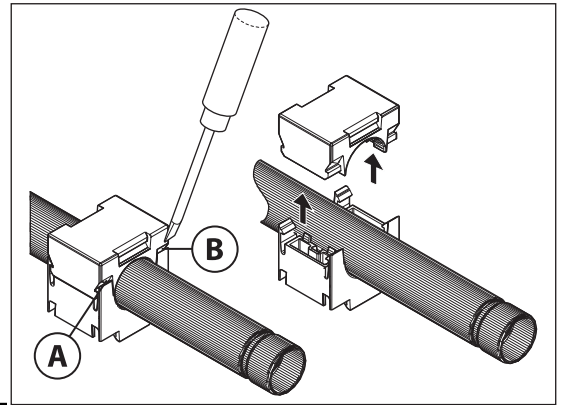

Feed Pipe Snap-Lock Assembly

Disassembly

1. Unscrew the union nut (A) completely.
2. Pull the feed piping and hose barb apart.
3. Take out the O-ring (B).
4. Inspect and oil O-ring (B). Change the O-ring (B) if worn, before reassembly.

Reassembly

1. Check that the barbed lock ring (C) is fitted to the feed pipe with barb pointing away from pipe opening.
2. Fit the oiled O-ring (B) on top of the lock ring (C).
3. Push the feed pipe and hose barb together.
4. Screw the union nut (A) on the hose barb and tighten union nut (A) by hand.

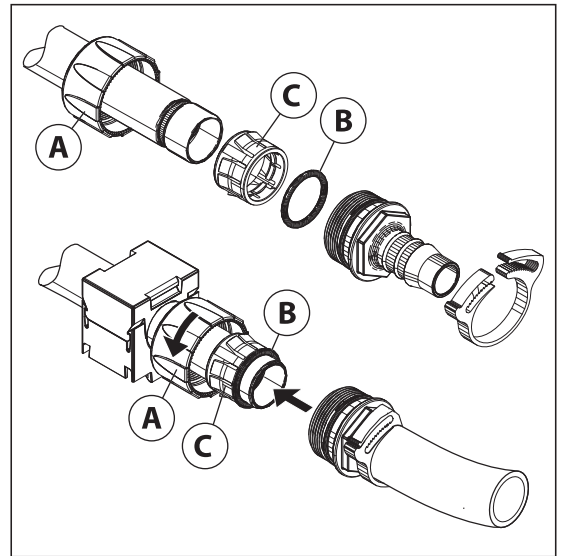

Initial Assembly of Fittings



ATTENTION! This method can only be used for pipes not fitted into pipe clamps.

1. Fit the barbed lock ring (C) to the feed pipe with barb pointing away from pipe opening.
2. Fit the oiled O-ring (B) on top of the lock ring (C).
3. Screw the union nut (A) on the hose barb.
4. Press the feed pipe and hose barb together.
5. Tighten the union nut (A) by hand if needed.

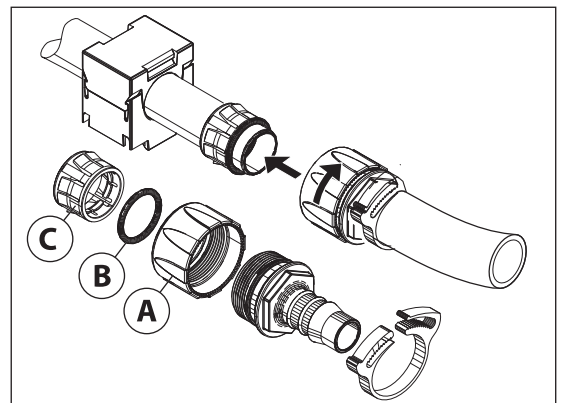

6 - Maintenance

Nozzle Holder Assembly

If leaks of fluid occur in the nozzle holders on the spray boom, it is necessary to check the sealing. To locate the O-rings disassemble the nozzle holder.

Recommendation is occasional maintenance of the O-rings and nozzle holders.

Usually is poor sealing caused by:

- Missing O-rings.
- Damaged or incorrectly seated O-rings.
- Dry or deformed O-rings.
- Foreign objects.

In Case of Leaks

Disassemble the nozzle holder and check condition of the O-rings. Replace, if damaged or cracked.

Disassemble Nozzle Holders

1. Example of an assembled nozzle holder, fitted to the spray boom.



2. Snapped together are the black plastic parts. To disassemble, insert a flat screwdriver (B) and press, until the locking piece (A) snaps out.

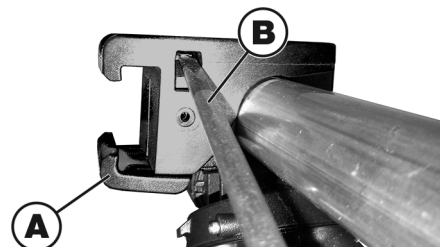
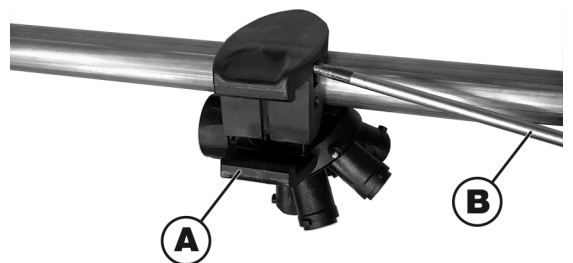

3. With the locking piece (B) removed, place the screwdriver as shown and pull to remove the upper part (C) of the nozzle holder.

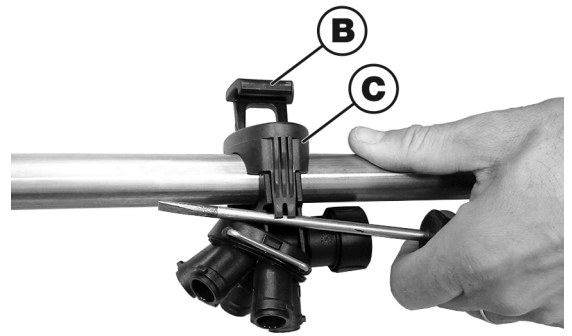

Here the separate locking piece (B) and the upper part (C).



4. Inside the lower part (D), the O-ring (E) is located.
5. Check condition and position of the O-ring. Replace and lubricate, if damaged or cracked.

i NOTE! When seated, the O-ring is supposed to be a little out of shape when it fits tightly around the hole in the nozzle pipe.

6. If reused, clean and lubricate, the O-ring.

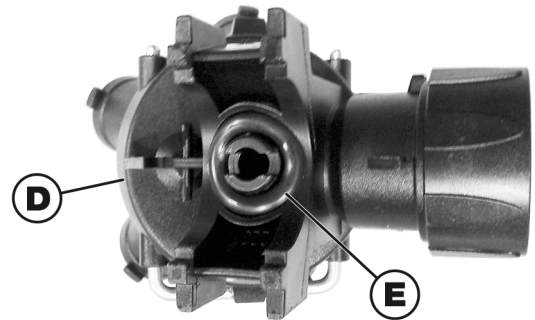

Reassemble Nozzle Holder

1. Lubricate the O-ring all the way around using a silicone lubricant or vegetable oil.
2. Place the O-ring inside the lower part.
3. Place the lower part on the nozzle pipe, so that the O-ring fits around the hole in the nozzle pipe, where the spray liquid exits to the nozzle holder.
4. Place the upper part on the opposite side of the nozzle pipe.
5. Press the parts together until they interlock.
6. Insert the locking piece in the upper part to secure it on the spray boom.

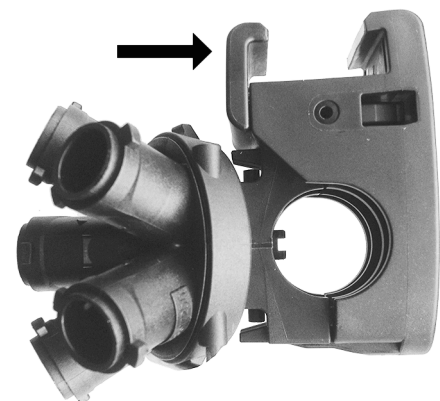
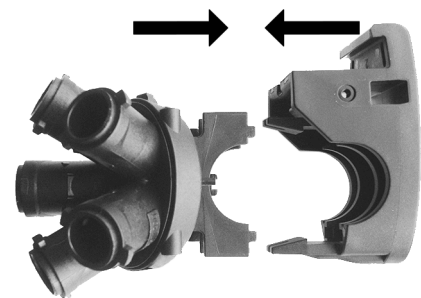

6 - Maintenance

Nozzle Pipe Assembly

If fluid leaks occur from the pipelines on the spray boom, it is necessary to check the sealing. It is necessary to disassemble the pipe fitting to locate the O-ring.

Recommendation is occasional maintenance of the O-rings and pipe assemblies.

Usually poor sealing is caused by:

- Missing O-ring or gasket.
- Damaged or incorrectly seated O-rings.
- Dry or deformed O-rings or gaskets.
- Foreign objects.

In Case of Leaks

DO NOT overtighten the union nut. Instead, disassemble the pipe fitting and check condition of the O-ring. Replace, if damaged or cracked.

Fitting Types

There is only one size for boom pipes in use, Ø25 mm. They share the same union nut, t-pieces, etc.

- X. O-ring for 25 mm pipes (part no. 24263000).
- Z. Lock ring Ø25 mm (part no. 33515500).

Disassemble Pipe Fittings

1. Example of an assembled pipe fitting.

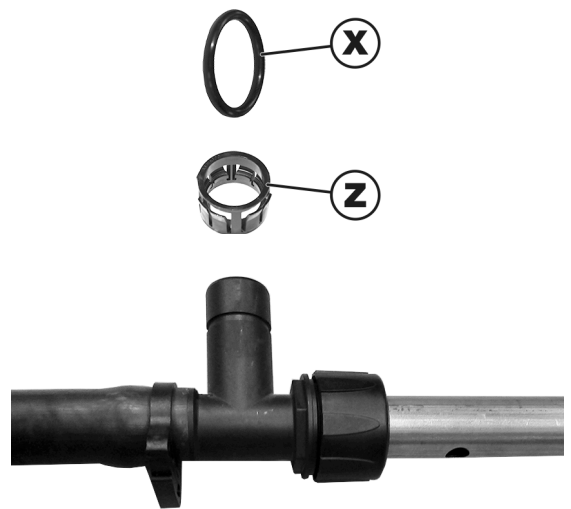

2. Unscrew the union nut (A).

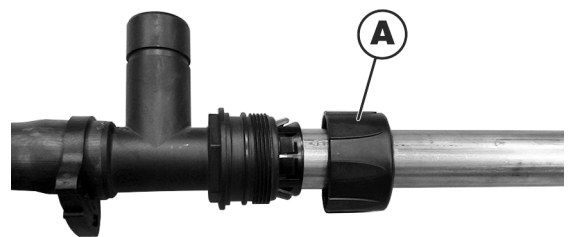

3. Pull the nozzle pipe (B) away from the T-piece (C).
4. A lock ring (D) and an O-ring (E) is located at the end of the pipe.
5. Check condition and position of the O-ring. Replace, if damaged or cracked.
6. If reused, clean and lubricate the O-ring.

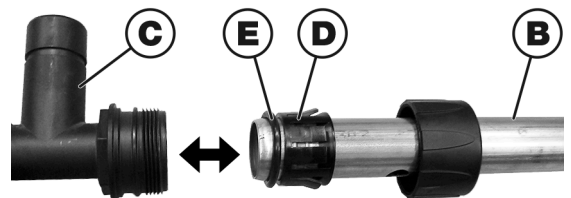

Remove Lock Ring

If necessary to replace the lock ring, remove the old one the following way:

1. Fit a union nut (A) in reverse direction.
2. Push the union nut (A) over the lock ring (D).

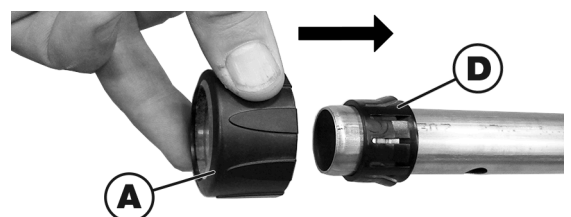

- Place the union nut (A) right behind the lock ring and pull to remove the lock ring (D) from the pipe.



Reassemble Pipe Fittings

- Place the union nut (A) and lock ring (D) on the pipe (B) in that order.
- Lubricate the O-ring all the way around using a silicone lubricant or vegetable oil.
- Place the O-ring (X) on the end of the pipe.
- Screw the union nut (A) onto the T-piece (C) and tighten the union nut (A) by hand.

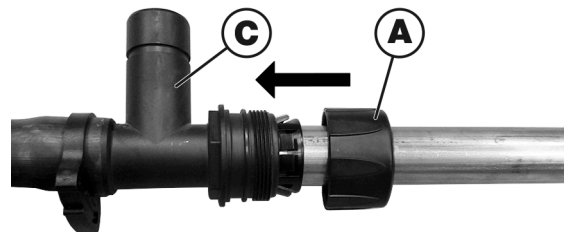
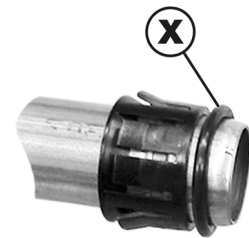
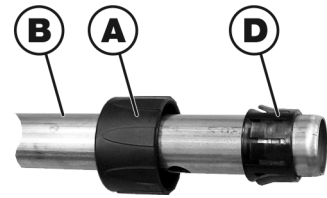

ATTENTION! Do NOT use tools for tightening the union nut!

Wear Bushing Replacement on ParaLift

Inspect and renew the wear bushes before they worn through.

- Connect the trailer to a tractor and unfold the boom to working position.
- Lift the boom centre frame with a lifting device and support it, until the load relieved from the parallelogram arms.
- Remove the screw (A), and pull out the pin (B) at one of the upper parallelogram arms.
- Replace the wear bushes.
- Refit the arm.
- Repeat this on the other upper arm.
- Disconnect the lower arms simultaneously, when changing wear bushes here.
- Apply grease into all grease nipples.
- Remove the lifting gear again.

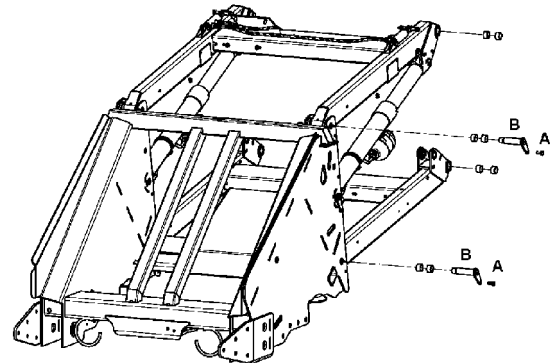

6 - Maintenance

Suspension Rubber Dampers

Replace the rubber dampers if they lose their efficiency.

1. Connect the sprayer to a tractor to prevent overbalancing.
2. Lift the rear end of the sprayer with e.g. a crane. Use lifting points as described in "Sprayer setup".
3. Loosen the nut below the suspension rubber dampers.
4. Remove the suspension rubber dampers and replace with new ones.
5. Tighten the nut below the suspension rubber dampers.
6. Lower the rear of the sprayer again.

Replacement of the Transmission Shaft Shield

- See the manufacturer's instruction book.

Replacement of Transmission Shaft Cross Journals

- See the manufacturer's instruction book.

Light Bulb Change

1. Switch off the light.
2. Loosen the screws on the lamp and remove the cover or lens.
3. Remove the bulb.
4. Fit a new bulb, refit the cover and tighten the screws.



ATTENTION! If halogen bulbs are used, never touch the bulb with your fingers. Natural moisture in the skin will cause the bulb to burn out, when the light is switched on. Always use a clean cloth or tissue when handling halogen bulbs.

Tyre Change



DANGER! If it is time to change tyres, it is recommended to leave this job to a specialist and follow the rules below. Some mounting instructions are usually printed on the tyre itself.

Failure to understand the mounting instructions will result in a bad seating of the tyre on the rim, and it could cause the tyre to burst leading to serious injury or death!

Never mount or use damaged tyres or rims! Use of a damaged, ruptured, distorted, welded or brazed rim is not allowed!

Mounting Instructions

- Always clean and inspect the rim before mounting a new tyre.
- Always check that the rim diameter corresponds exactly to the rim diameter moulded on the tyre.
- Always inspect the tyre inside for cuts, penetrating objects or other damages. Repairable damages should be repaired before installing the tube. Tyres with non-repairable damages must never be used.
- Always inspect the inside of the tyre for dirt or foreign objects. Remove this before installing a new tyre tube.
- Always use new tubes of recommended size. When fitting new tyres, always fit new tubes. Do not use tubes for tubeless tyres.
- Before mounting, always lubricate both tyre beads and rim flange with approved lubricating agent or equivalent anti-corrosion lubricant. Never use petroleum based greases and oils, because they may damage the tyre. Using the appropriate lubricant will prevent the tyre from slipping on the rim.
- Always use specialised tools for mounting the tyres as recommended by the tyre supplier.
- Make sure that the tyre is centred, and that the beads are perfectly seated on the rim - otherwise tearing of the bead wire may occur.
- Inflate the tyre to 1-1.3 bar (14.5-19 psi), then check whether both beads are seated perfectly on the rim. If any of the beads do not seat correctly, deflate the assembly and re-centre the beads, before starting inflation of the tyre.
If the beads are seated correctly on the rim at 1-1.3 bar (14.5-19 psi), inflate the tyre to a maximum of 2.5 bar (36 psi), until they seat perfectly on the rim.
- Never exceed the maximum mounting pressure moulded on the tyre!
- After mounting the tyres, adjust the inflation pressure to the operation pressure as recommended.

6 - Maintenance

Venting the Boom Hydraulics

If disassembling the hydraulic cylinders or hoses, it is necessary to vent the cylinders after reassembly.



DANGER! Failing to vent the hydraulic system when needed, may result in violent boom movements and poor boom performance. Risk of damage to the boom parts or foreign objects nearby. Risk of severe injuries or death.



ATTENTION! Not all hydraulic cylinders have a venting option. In this case, you must loosen the hydraulic hose connected to the cylinder to let the air out this way. Note that ORFS fittings are used - be careful not to damage the sealing O-ring, when venting the cylinder.



ATTENTION! The following venting instructions are for double acting cylinders only. For single acting cylinders, such as for the boom tilt motion, the venting is easily completed: After service, apply hydraulic pressure to the cylinder, retract and extend the piston approximately 5 times, and the air is then removed from the system automatically.

Venting Sequence

Follow this sequence to complete an efficient venting of air in the system.

1. Boom centre: Vent cylinders for inner wings.
2. Boom wings: Vent cylinders for 1st outer wing.
3. Boom wings: Vent cylinders for 2nd outer wing, if applicable.
4. Boom centre: Vent cylinder for slant motion.

Venting Procedure

Follow these steps to complete the venting. Begin with both valves/venting screws (A) and (B) closed.

1. Retract the cylinder piston.
2. Remove the dust caps from the venting valves.
3. Fit a clear 5 mm hose to the venting valve (A) and lead it into a suitable container.
4. Open the venting valve (A).
5. Activate the hydraulic oil pressure and fully extend the piston.
6. Close the venting valve (A) and remove the hose.
7. Fit the clear hose to the other venting valve (B).
8. Open the venting valve (B).
9. Activate the hydraulic oil pressure and fully retract the piston.
10. Close the venting valve (B) and remove the hose.
11. Repeat steps 3 - 10 a few times until air is no longer visible in the hose.
12. Refit the dust caps. Venting completed for this cylinder.
13. Check your hydraulic oil level - top up if needed.

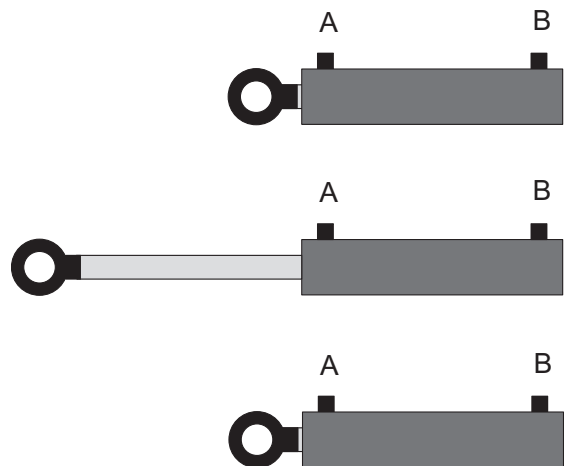

DANGER! Be careful when operating the cylinders. Make sure unauthorized persons are not in the working area, when folding or unfolding the boom! When retracting the pistons into the cylinders, keep fingers, tools and clothes away from the piston. Risk of being trapped between moving boom parts or folded boom sections, resulting in severe injuries or death.



ATTENTION! Depending on the boom design, it might be more practical to begin with the cylinder extended.



ATTENTION! A helping hand is useful to complete the venting procedure.

Venting the Steering Hydraulics

If disassembling the steering cylinder hydraulics, it is necessary to vent the cylinders after reassembly.

Depending on the sprayer size, the venting screws (A) are installed as shown on the pictures.

1. Start by entering Menu 4.5 "Emergency Mode" on your SmartCom Controller, then enter Menu 4.5.3 and choose "Limp home".

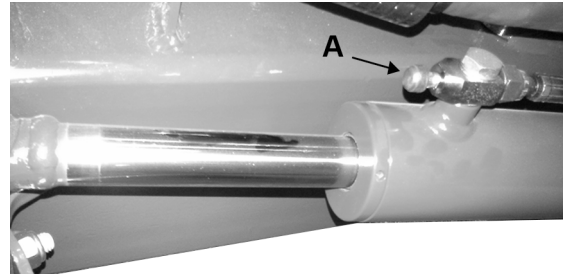

Menu 4.5.3 enables or disables limp home mode for track functions. Turn it ON/OFF by selecting either of the menus:

- Menu 4.5.3.1 [Normal, protection enabled].
- Menu 4.5.3.2 [Limp home, protection disabled].

When limp home is enabled, this disables the track protection. Then manual alignment of the track is possible.

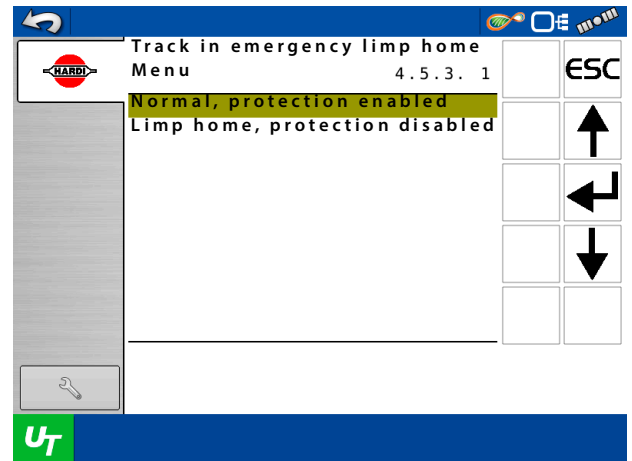

2. Remove the dust cap from the venting screw (A) on the left side steering cylinder.
3. Fit a clear 5 mm hose to the venting screw and lead it into a catch can.
4. Open the venting screw 1/8 turn and then fully steer to the left (retract cylinder).
5. Hold the steering position, until air is no longer visible in the hose.
6. Close the venting screw (A) again.
7. Repeat the procedure for the right side cylinder.
8. Fully steer from the left to right 8-10 times.
9. Complete the venting procedure again to ensure that there is no air in the system.
10. Fit the dust caps onto the venting screws again.

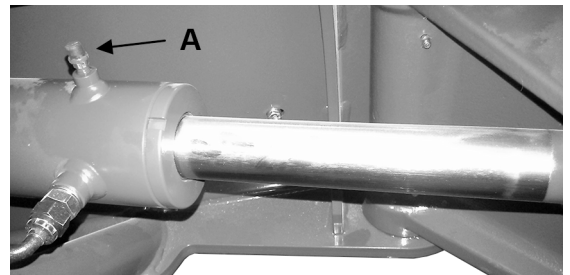

DANGER! Be careful when operating the steering! Make sure that there is space enough to steer the sprayer from side to side! Only persons working on the sprayer allowed in the moving area of the sprayer!

6 - Maintenance

Readjustment of Boom

General Info

Before commencing adjustment jobs, please go through this checklist.

1. Keep the sprayer well lubricated (see the section "Lubrication").
2. Connect the sprayer to the tractor.
3. Place the tractor and sprayer on level and solid ground.
4. Activate the parking brakes for the tractor and trailer.
5. Place wheel chocks under the wheels to prevent rolling.
6. Unfold the boom.
7. Set slanting angle to neutral position (horizontal).
8. Place strong supports below the centre section and all boom sections to relieve the load from the hydraulic cylinders. If you have a lifting crane, support the centre section as a minimum, as this is the heaviest boom part (up to 1000 kg).



DANGER! While carrying out adjustment, allow no one under the boom.



ATTENTION! Boom sections not supported during an adjustment job might fall down or be difficult to adjust.

9. Check the boom alignment.

Use a spirit level, or measure the distance to the ground from similar points in both ends of the boom wing (use this method for horizontal alignment and only on level ground). When using the latter method, both distances should be equal to obtain a horizontal boom.



DANGER! Carry out adjustment of hydraulic cylinders without pressure in the system.



ATTENTION! Carry out adjustment equally for both the left and right boom wings.



ATTENTION! For information on boom terminology, see "Spray Boom" on page 67.

Boom Adjustment Order

When adjusting your boom, please start from the inner boom wing and move outwards.



NOTE! Depending on the width of your boom, some of the instructions on the following pages might apply for several wing connections. Others might be redundant.

Adjustment of Boom Tilt

The unfolded spray boom must be horizontal before starting a spray job. If needed, horizontal adjustment of the boom wings is possible by adjusting the ram eye on the hydraulic tilt cylinder on both sides of the sprayer.



NOTE! The boom can tilt down to 4 degrees below horizontal level (only if having AutoTerrain installed).

Steps for Adjustment - Boom Width 27-39 Meters

1. Disconnect the ram eye from the inner wing.



ATTENTION! If not replacing the hydraulic cylinder, it is not necessary to disassemble the ram eye from the boom. Instead, rotate the piston rod by turning it with a wrench placed just behind the ram eye.

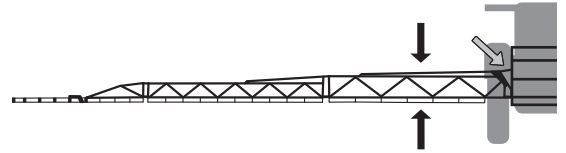

2. Loosen the counter nut (A) and the grub screw inside. This will unlock the ram eye from the cylinder's piston rod.
3. With a wrench fitted on the flat surfaces on the end of the ram (just behind A), the ram is now turned inwards or outwards in relation to the cylinder. The direction depends on your need for adjustment.

- Raise the boom wing: Turn the ram inwards.
- Lower the boom wing: Turn the ram outwards.

4. To be able to lock the ram eye to the piston rod after adjustment, turn the ram eye 1 full round at a time; this will move the ram eye 2 mm sideways.
5. Reconnect the ram eye to the boom parts to check the horizontal level of the boom wing.

If further adjustment is needed, go back to step 2.

If horizontal alignment is OK, tighten the pin bolt and the counter nut (A).

Adjustment is now completed.

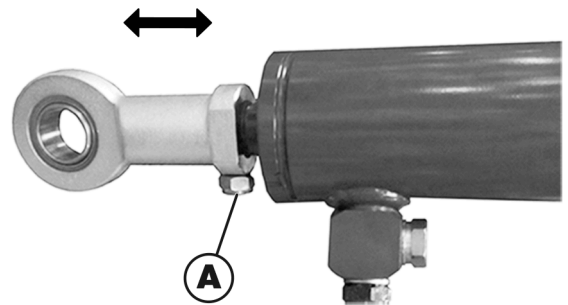

Steps for Adjustment - Boom Width 24 Meters

The procedure is the same as above; however loosen the counter nut (B) here to adjust the ram eye inwards or outwards by turning it.

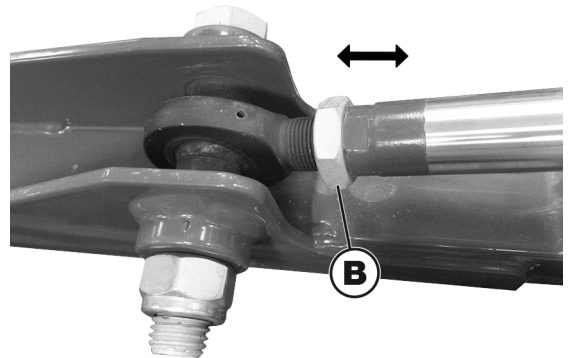

6 - Maintenance

Horizontal Alignment of Inner Sections

For booms with hydraulic pivot joint.

This alignment is to compensate for the wind resistance when driving with an unfolded boom, as well as keeping a good balance in the boom when driving on uneven fields. The boom adjustment is relatively to the direction of driving.

Steps for Adjustment

1. Turn the stop bolt (A).

Wrench size = 30 mm.

- To bring the boom forwards (B):

Turn the stop bolt counter-clockwise and tighten the counter nut.

Torque = 250 Nm.

- To bring the boom backwards (C):

Loosen the counter nut and turn the stop bolt clockwise.

2. Stand near the boom centre and look towards the boom end. Compared to being on a perpendicular line to the direction of driving, the boom should now be adjusted a little forward (B).

The boom tip must be between 100 and 450 mm ahead of the perpendicular line.

3. When the plunger cylinder (D) is fully pressurized, the piston stroke (E) must not exceed 38 mm. Adjust the stop bolt (A) accordingly.
4. Adjustment is completed, when the boom is aligned within the range mentioned in step 2. After aligning other boom sections, check if realigning is needed here.

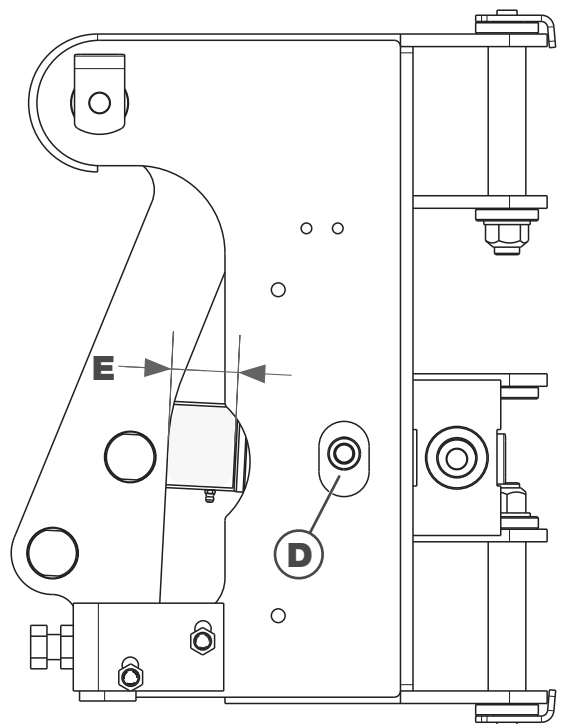
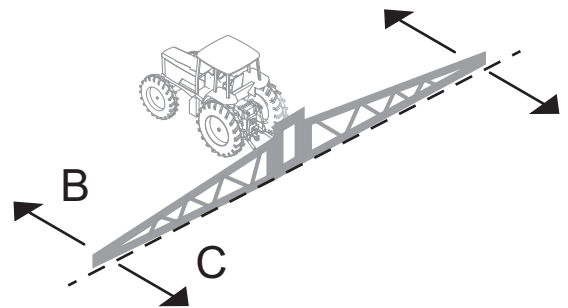
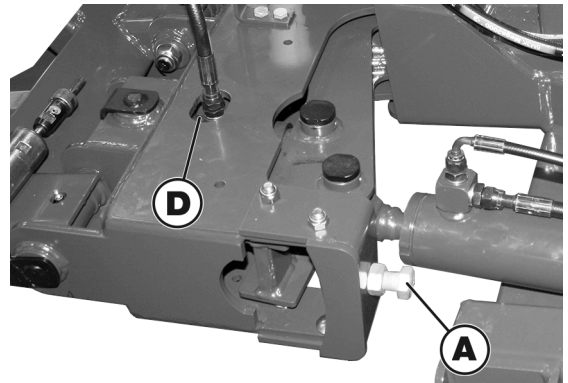
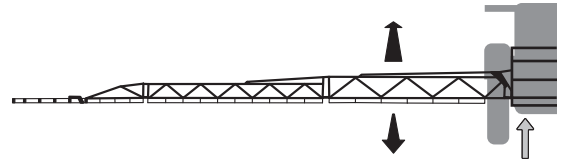

Horizontal Alignment of Breakaway Section

Complete the following steps to adjust the breakaway to align it with the outer section of the boom.

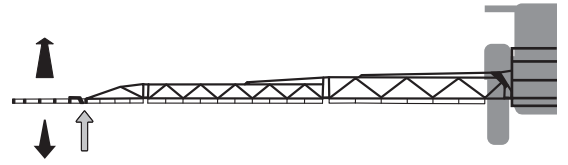

1. Loosen the bolts and lock nuts (A) - but do not remove them.
2. There are four sets of bolts and nuts in all, mounted in both sides of the steel bracket (B).

Wrench size = 17 mm.

On the picture, one bolt and nut removed. The slot holes in the steel bracket allows adjustment. The steel bracket attach to the breakaway.

3. Align the breakaway with the outer section by moving the bracket.
4. Retighten the bolt and nuts. Torque = 180 Nm.

Adjustment is completed.

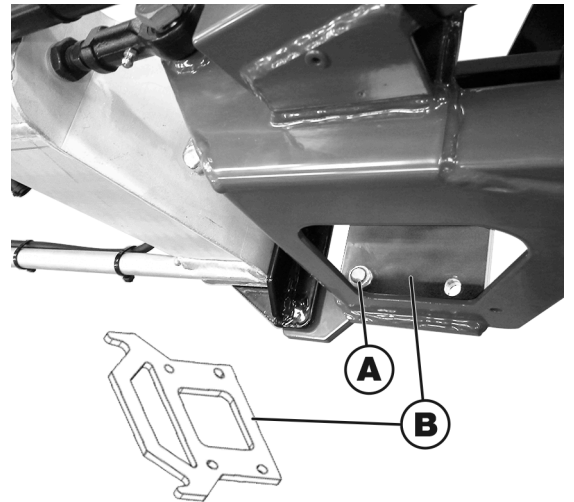

6 - Maintenance

Vertical Alignment of Outer Sections 1 and 2

Steps for Adjustment

1. Start with outer section 1, which is aligned with the inner section.

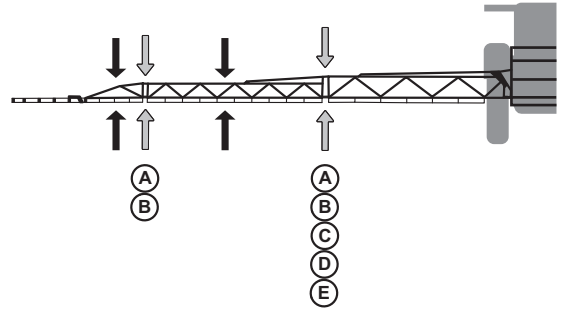

2. At the top of the boom, the nuts (A, B) are turned.

Wrench size = 41 mm.

- Raise the boom: Loosen (A), tighten (B).
- Lower the boom: Loosen (B), tighten (A).

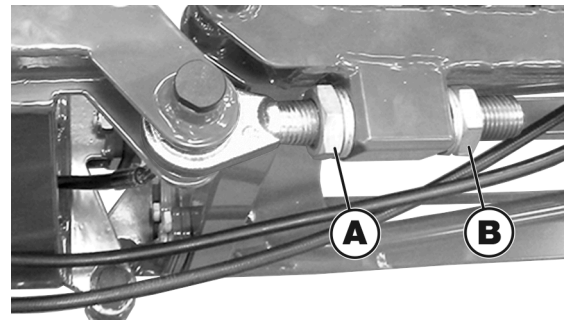

3. If necessary, adjust the ram eye (C) at the lower end of the boom. Remove the black pin (D), loosen the counter nut (E) and turn the ram eye 180°. Tighten the counter nut and refit the black pin. Check alignment of the boom section.

4. When outer section 1 aligns, tighten the counter nuts.

Completed adjustment is, when the alignment is straight, and the folding is trouble-free.

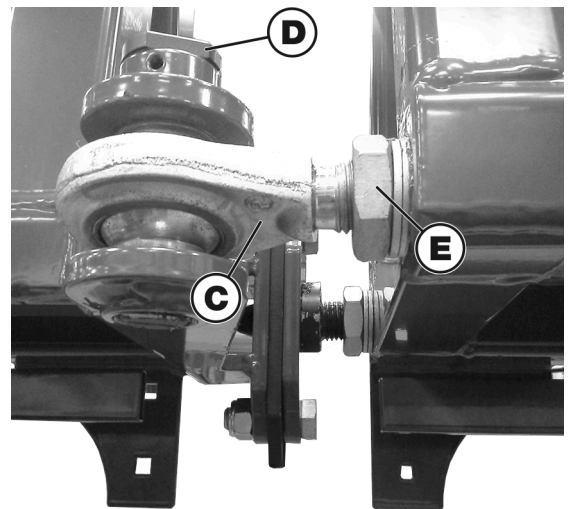

5. Align the outer section 2 with outer section 1 in the same way by completing steps 2 – 4 for the upper ram eye.

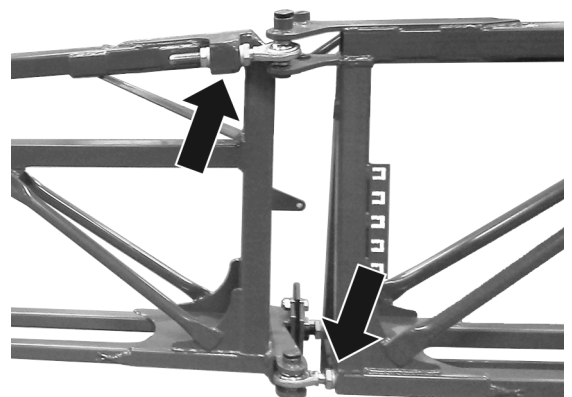

Adjustment of Boom Lock

Description of Boom Lock Mechanism

To prevent accidental folding of the spray boom while spraying, the boom joints interlock automatically when fully unfolded. The conical bolt (A) will guide the boom sections into the interlocking position.

A specially designed steel plate (B) lifts up, when the conical bolt (A) passes through the plate. The plate (B) will fall down behind the bolt head, thus securing the unfolded position.

When folding, a hydraulic cylinder (C) will temporarily pull up the steel plate (B) to allow the boom sections to separate.

i NOTE! On the picture, the cylinder (C) is detached from the steel plate (B). The cylinder must attach during operation of the boom.

⚠ ATTENTION! The following boom alignment is only carried out, if changing the positions of the rubber pads on the boom is insufficient to steer the boom sections into the folded transport position. When folding the boom, the upper edges of the boom sections should align to allow the hydraulic boom locks to engage.

Horizontal Alignment of the Boom

If necessary, adjust the bolt (A) sideways.

1. Loosen the lock nut (D).
Wrench size = 41 mm.
2. Turn lock bolt (A), until the boom sections align.
Wrench size = 46 mm.

⚠ ATTENTION! The lock bolt is eccentric. Always turn it 1 full round at a time; this will move the lock bolt 3 mm back or forth. Ensure that the lock bolt aligns with the centre of the hole in the lock mechanism, when the adjustment is completed.

3. Retighten the lock nut (D). Torque = 250 Nm.
Adjustment completed.

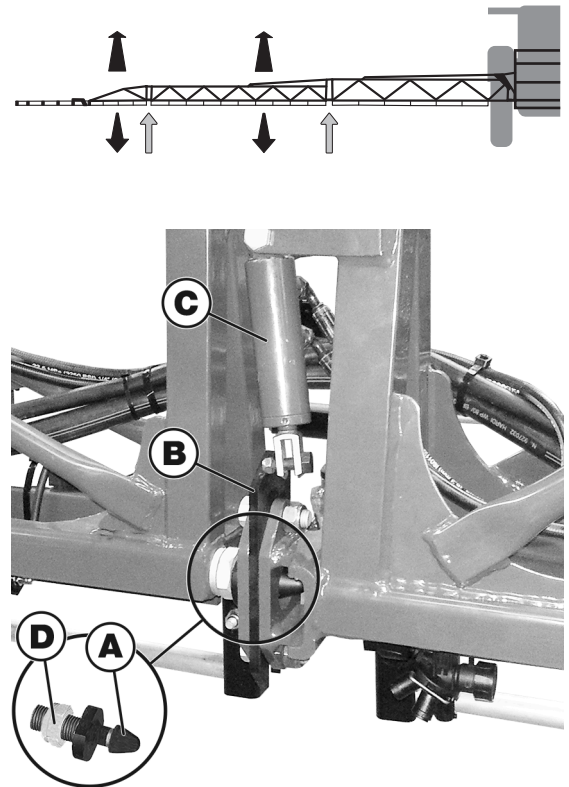

Vertical Alignment of Breakaway Section

Align the breakaway with the outer section of the boom.

Step for Adjustment

1. Loosen the nut (A).
Wrench size = 24 mm.
2. The hexagon (B) is turned.
 - Turn clockwise: The breakaway raises.
 - Turn counter-clockwise: The breakaway lowers.
3. When the breakaway aligns, tighten the nut (A).
Adjustment is completed.

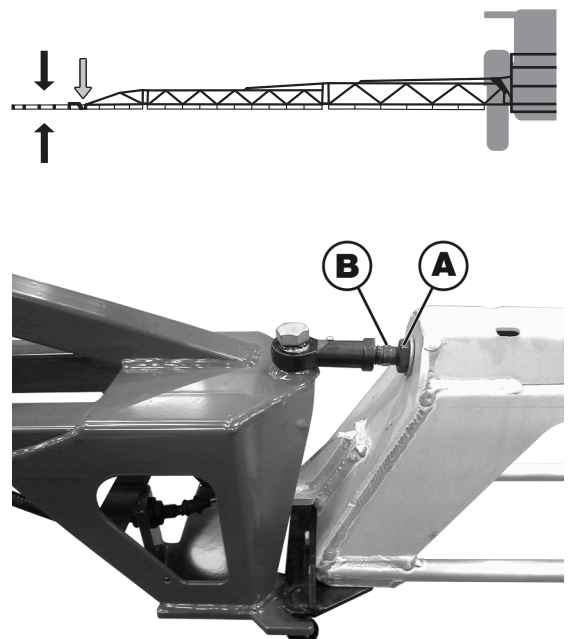

6 - Maintenance

Adjustment of Folding Cylinder

This adjustment process is relevant for the folding cylinders between inner and outer wing (and between 1st and 2nd outer wing on 3-folded booms).

1. The folding cylinder must be adjusted when the boom is folded into transport position. Therefore, start by folding your boom into transport position.
2. Make sure that the piston rod is entirely pulled out, either by using hydraulics or by pulling it out manually.



3. As a starting point, adjust the ram link eye out so 20mm of thread (incl. the thickness of the counter nut) is visible.



4. This should align the ram eye into the folding arm, so the eye hole exceeds the arm hole by approximately x0,5 as shown.

If necessary, loosen the counter nut and adjust the ram eye until it exceeds the hole as shown on the photo (A). Remember to tighten the counter nut again.

A proper adjustment will ensure just enough mechanism folding pressure, keeping the outer wing in folded transport position.



5. Finally push the piston rod a bit into the cylinder until the ram eye fits the hole.
6. Fit the black pin (B) and the safety cutter pin (C).
Replace if needed.



Spring Load for Breakaway Section

The breakaway section at the boom end will move back or forth, if it hits a stationary object, e.g. a pole or a tree, when driving with an unfolded spray boom. The spring on the outer section of the boom will pull the breakaway back into place, when the boom is clear of the object. When spraying, the breakaway may also sway a little if driving on uneven ground.

The spring is preloaded from the factory - but adjustment is needed, if:

- The breakaway is continuously swaying a lot due to a bumpy field (tighten the spring).
- The breakaway has become very hard to move by hand, when the sprayer is at a standstill (loosen the spring).
- Reattachment is necessary due to replacement of the spring, cable for spring or other parts.

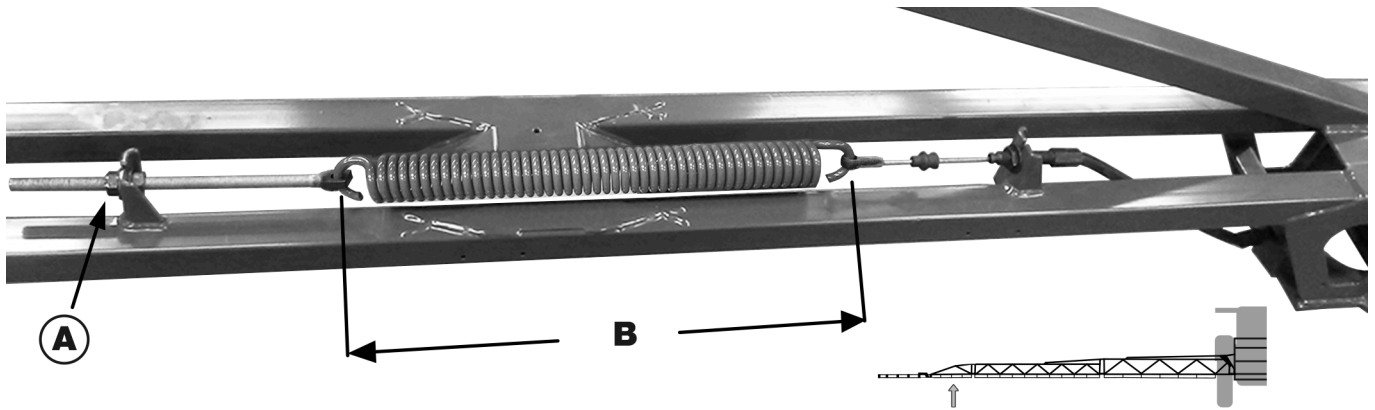

Steps for Adjustment

- Turn these nuts to adjust the spring.
- Dimension of preload of the spring. Factory setting is 480mm. Maximum preload is 550mm.



WARNING! Risk of squeezing. Keep fingers and clothes away from the spring windings, when adjusting the spring.

Yaw Damping

The unfolded spray boom will create yaw movements, when:

- Driving over uneven terrain.
- Turning on headland.
- Speeding up.
- Braking.

The three accumulators located in the boom centre act as dampers for the yaw movements, when driving in the field.

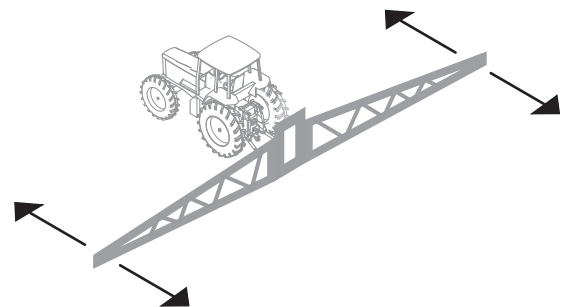

Damping Function

Each accumulator contains nitrogen gas and hydraulic oil, separated by a diaphragm. When the boom makes a yaw movement, hydraulic oil will be transferred into the accumulator. The oil pushes the diaphragm while compressing the gas. When this compression overcomes the oil pressure from the boom, the boom wing is moved back to its original position damped by the oil flow in the circuit.

6 - Maintenance

Accumulator Service

If the yaw damping seems to be insufficient, the accumulators need to be recharged or replaced. Ask your HARDI dealer to assist you.

1. Check for any leaks.
2. Check pressure setting for the accumulators in the test sockets, which are located in the hydraulic block (A). Hydraulic hoses for the accumulators are also connected to this block.
3. Fill nitrogen gas (N₂) into the accumulators:
 - Gas pressure = 12 bar -0/+2 for booms of 24-28 meters.
 - Gas pressure = 18 bar -0/+2 for booms of 30-39 meters.
 - The gas volume in the accumulator is approx. 0.5 litres.
4. Fill hydraulic oil into the accumulators:
 - Oil pressure = 20 bar -0/+2 for booms of 24-28 meters.
 - Oil pressure = 35 bar -0/+2 for booms of 30-39 meters.

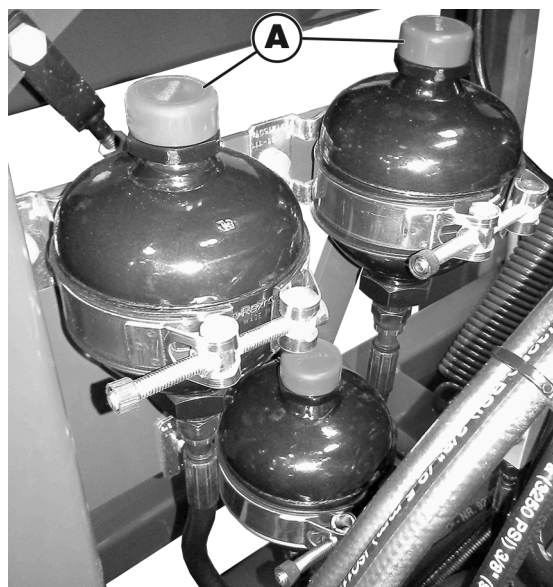

DANGER! Do not fill the accumulators with other gases, such as air or pure oxygen. Risk of explosion.



ATTENTION! The accumulators are automatically pressurised at 35 bar, when the boom is unfolded.

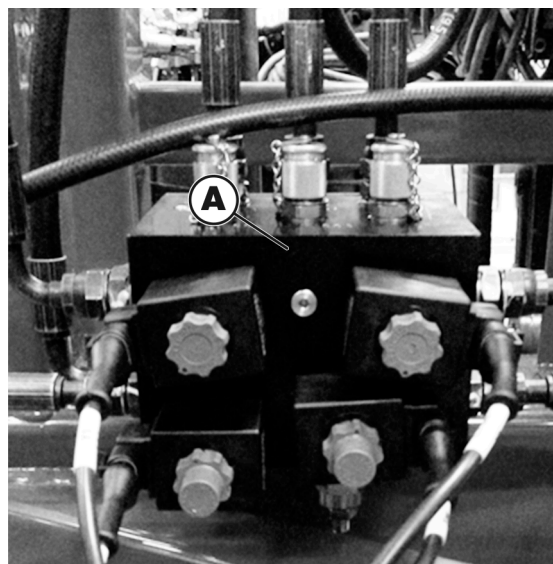

Hydraulic Block for Yaw

Item	Port on Hydraulic Block
Hydraulic hoses for accumulators	ACC1, ACC2, ACC3
Test sockets for accumulators	MACC1, MACC2, MACC3, TM
Yaw cylinders on spray boom	C1, C2, C3
Return oil back to tractor	T



NOTE! For more details, see the hydraulic diagram in the chapter "Technical Specifications" in this book.

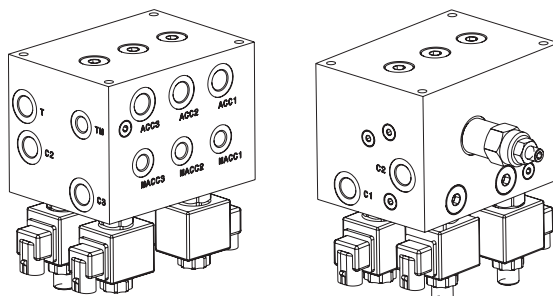

Alignment of Rubber Pads on Spray Boom

When folded, check if the boom rests correctly on the rubber pads.

The rubber pads help to steer the boom into the transport position. The rubber pads also protect the boom parts during folding and transport.

Steps for Adjustment

1. Fold the boom and check the positions of the rubber pads (A).
When the folding completed, they must be in touch.
2. If necessary to realign, slightly loosen the four lock nuts (B). Wrench size = 17 mm.
3. Move the steel bracket with the rubber pad sideways to the desired position.
4. Tighten the four lock nuts (B) to lock the position of the rubber pad.
5. Adjust other rubber pads on the boom as needed.

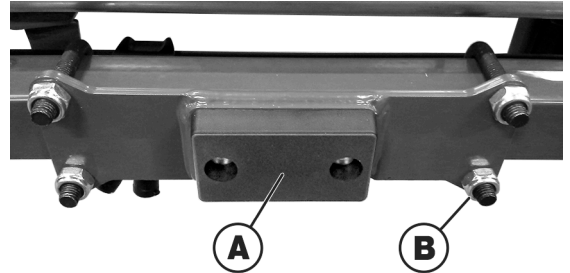

6 - Maintenance

Adjustment Procedure for MK IV LGM Load Genies

1. Ensure the machine is turned off and all pressure is released from the air tank.
2. Loosen the differential lock nut and screw the differential adjustment screw fully home (finger tight). Using a spanner, tighten the differential screw an additional $\frac{1}{4}$ turn past finger tight. This causes the valve ball to seat itself in to the valve body fully.
3. Back off the differential adjustment screw $\frac{1}{2}$ turn.
4. Loosen the range lock nut.
5. Run compressor to pressure cut-out. Set the cut-out adjustment to 8.1 bar using the range adjustment screw. Screw in for higher cut-out and screw out for lower cut-out.
6. Bleed air from the tank and note the cut-in pressure. Set the cut-in pressure to 6.8 bar using the differential adjustment screw. Screw in for lower cut-in and screw out for higher cut-in.
7. Re-check the cut-out pressure as adjustments made in step 6 will affect the cut-out pressure. Adjust as necessary.
8. Run compressor again to cut-out pressure. If air is rapidly bleeding from around the unloading lever, it can often be stopped by biasing the adjustment screws to one side or the other with your thumb. Once the position for minimum leakage is found, hold it there and tighten the differential lock nut.
9. Tighten the range lock nut.

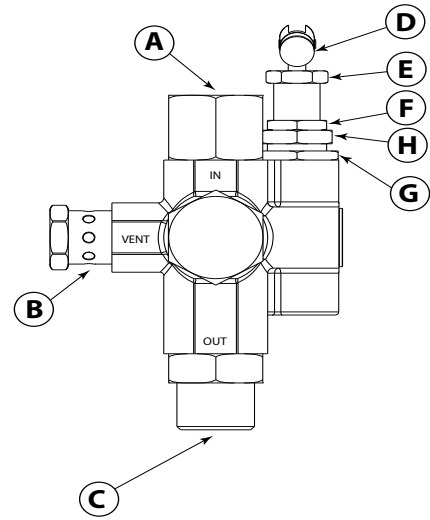

Off-Season Storage

General Info

To preserve the sprayer condition and to protect its components, carry out following off-season storage program.

Before Storage

When the spraying season is over, you should devote some extra time to the sprayer. If chemical residues left over in the sprayer for longer periods, it may reduce the life of its individual components.

1. Clean the sprayer completely both inside and outside as described under "Cleaning" on page 118. Make sure there is no chemical residues left in the sprayer by cleaning all valves, hoses and auxiliary equipment with a cleaning agent and flushing with clean water afterwards.
2. Replace any damaged seals and repair any leaks.
3. Completely empty the sprayer, and let the pump work for a few minutes. Operate all valves and handles to drain as much water out off the liquid system as possible. Let the pump run, until air comes out of all nozzles. Also, drain the rinsing tank.
4. Anti-frost protection:
 - A. Complete the inside and outside cleaning of the sprayer.
 - B. Pour approximately 50 litres of antifreeze mixture (e.g glycol and water), into the MainTank. Include any remaining water hidden in the liquid system in the mixture.

Depending on local winter temperatures, use the recommended mixture ratio in the table below:

Temperature (°C)	Water Volume (litres)	Glycol Volume (litres)
-7	10	2.5
-12	10	4.3
-20	10	6.7
-31	10	10
-40	10	12.2

- C. Turn on the pump and operate all valves and functions, operating units, TurboFiller etc., allowing the antifreeze mixture to distribute around the entire liquid system without leaving any unmixed water in hidden places.

Unmixed water will freeze and possibly damage the sprayer components!

- D. Open the operating unit main ON/OFF valve and the distribution valves, so that the antifreeze sprays through the nozzles as well.

The antifreeze mixture will also prevent O-rings, seals, diaphragms, etc. from drying out.

- E. Empty filters and boom pipes. Remember to unscrew the end plugs, as unmixed water can build up in blind pipe ends causing risk of a broken end plug or pipe, when pressurizing the boom pipes at the next spray job.

After filling the antifreeze mixture, also remove the sensor (A) connected to the nozzle pressure gauge, as this area is a possible blind end.

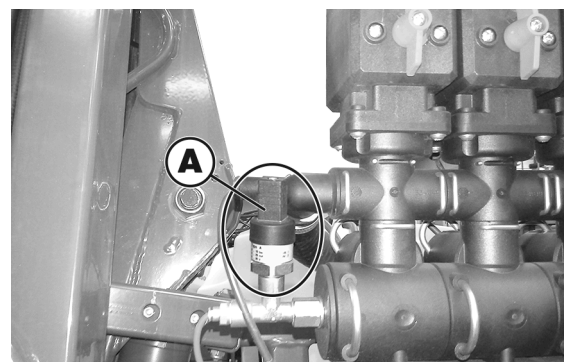

6. Remove the glycerine-filled pressure gauges and store them frost-free in vertical position. Lubricate all lubricating points according to the lubricating schemes - regardless of intervals stated.
7. When the sprayer is dry, remove rust from scratches or damage in the paint, if any, and touch up the paint.

6 - Maintenance

8. Apply a thin layer of anti-corrosion oil (e.g. SHELL ENSIS FLUID, CASTROL RUSTILO or similar) on all metal parts. Avoid oil on rubber parts, hoses and tyres.
 9. Fold the boom into transport position and relieve the pressure from all hydraulic functions.
 10. All unplugged electric plugs and sockets are to be stored in a dry plastic bag to protect them against moisture, dirt and corrosion.
 11. Remove the control boxes and computer display from the tractor. Store them dry and clean (indoor) in a non-condensing environment.
 12. Wipe hydraulic snap couplers clean and fit the dust caps.
 13. Apply grease to all hydraulic ram piston rods, not fully retracted in the housing, to protect against corrosion.
 14. Place the wheel axle on jack stands to prevent moisture damage and deformation of the tyres. Apply tyre blacking to the tyre walls to preserve the rubber.
 15. Drain the air tank for condensed water.
 16. Cover the sprayer with a tarpaulin to protect against dust. Ensure ventilation to prevent condensation.
-

After Storage

After a storage period, the sprayer should be prepared for the next season the following way:

1. Remove the tarpaulin.
 2. Remove the jack stands from the wheel axle, and adjust the tyre pressure.
 3. Wipe off the grease from the hydraulic ram piston rods.
 4. Fit the pressure gauges again. Seal with Teflon tape or similar.
 5. Connect the sprayer to the tractor, including pneumatic, hydraulic, electric and electronic connections. Check that the hoses and cables are free to move along when driving with the sprayer. No rubbing or stretching of cables and hoses.
 6. Check the hydraulic hoses for damage and correct connection to the tractor (see flow directions marked on the hoses).
 7. Check for correct connection between the PTO shaft and the tractor, and protection guards are in good working order. See the PTO instruction manual delivered for more about correct installation.
 8. Drain the antifreeze mixture from the MainTank and spray boom.
 9. Fill with clean water and check all functions. Do a liquid test:
 - A. Fill a small amount of water into the MainTank and circulate it around the liquid system.
 - B. Manually set spray pressure to 5 bar.
 - C. Check for leaks and repair if any.
 - D. Check spray patterns and water jets from the nozzles.
 10. Rinse the entire sprayer liquid system with clean water.
 11. Check that the MainTank is clean inside and check the function of the drain valve.
 12. Check for correct connection to the tractor and that hydraulic brake hoses are intact and without damage.
 13. Check the working order of the brakes. Please note reduced brake power, until the rust worn off the drums. Always brake lightly until the drums are clean.
 14. Check that the electric cables to the tractor are intact and correctly connected. Also, check that:
 - Cable sheaths are without damage due to wear, stretching or rubbing.
 - Electric plugs are without copper rust and damage.
 - Electric boxes are without cracks.
 15. Check traffic lights are visible and in good working order. Check the protection glasses are clean and without damage.
 16. Check the speed sensor and other sensors are in good condition and free of dirt. Check that the spray boom folds correctly. Make adjustments if needed and repair oil leaks if any.
 17. Check that the spray boom folds correctly. Make adjustments if needed and repair oil leaks if any.
 18. Check that the boom hydraulic hoses and electric cables are in place, and follow the folding movements without damage.
-

Operational Problems

General Info



DANGER! Trained personnel should be involved in fault finding, as this is hazardous work! It may be necessary to have the sprayer operating to complete the fault finding.

Operational incidents are often due to the same reasons:

- A suction leak reduces the pump pressure and may interrupt suction completely. It can also cause pulsation in the pressure hoses.
- A clogged suction filter may reduce suction or interrupt and prevent the pump from running normally.
- A clogged pressure filter increases pressure in the fluid system in front of the pressure filter. This may open the safety valve.
- Clogged in-line filters or nozzle filters increase pressure in the pressure gauge, but it decreases pressure at the nozzles.
- Impurities sucked in by the pump may prevent the valves from closing correctly, thus reducing the pump flow.
- A poor reassembly of the pump elements, especially the diaphragm covers, can cause air intakes or leaks and reduces the pump flow.
- Rusted or dirty hydraulic components cause bad connections and premature wear.
- A poorly charged or faulty battery causes failure and faults in the electrical system.

Always check

- Suction and pressure filters, as well as nozzles, are clean.
- Hoses are free of leaks, cracks, and kinks, especially on suction hoses.
- Gaskets and O-rings are present and in good condition.
- Pressure gauges are in good working order. Application rate accuracy depends on it.
- Operating unit functions properly. Use clean water to check.
- Hydraulic components are clean.
- The tractor battery and its connectors are in good condition.

7 - Fault Finding

Liquid System

FAULT	PROBABLE CAUSE	CONTROL / REMEDY
No spray from boom when turned on.	SmartValve valve position is incorrect.	Set correct valve position for spraying.
	Suction/pressure filters are clogged.	Clean suction and pressure filters.
	No suction from tank.	See if suction fitting in main tank sump is free of sedimentation. Clean if needed.
Lack of pressure.	Incorrect assembly.	Boost valve has a defect (it is located at the bottom of the cyclone filter). The valve seat is worn or missing.
	Air in system.	Fill suction hose with water for initial priming.
	Too much agitation.	Close the agitation valve.
	Pump valves are clogged or worn.	Check for obstructions and wear.
	Clogged filters.	Clean all filters.
	Defective pressure gauge.	Check for dirt at inlet of pressure gauge.
Pressure dropping.	Filters are clogging.	Clean all filters. Fill with cleaner water. If using powders, make sure agitation is on.
	Nozzles are worn.	Check nozzle output. Replace nozzles, if the deviation in output exceeds 10%.
	Sucking air towards end of tank load.	Reduce pump rpm.
Pressure increasing.	Pressure filters beginning to clog.	Clean all filters.
Formation of foam.	Air is being sucked into system.	Check tightness / gaskets / O-rings of all fittings on suction side.
	Excessive liquid agitation.	Reduce pump rpm.
		Check safety valve is tight.
		Ensure returns inside the tank are present.
Operating unit is not functioning, or it is having a malfunction.	Blown fuse(s).	Check mechanical function of micro switches. Use cleaning/lubricating agent if the switch does not operate freely.
		Check motor current, max. 450-500 mA. If over, change the motor.
	Wrong polarity.	Brown to positive (+). Blue to negative (-).
	Valves not closing properly.	Check valve seals for obstructions.
		Check micro switch plate position. Loosen the screws holding the plate a 1/2 turn.
	No power.	Wrong polarity. Check that brown is positive (+), blue is negative (-).
		Check print plate for dry solder joints or loose connections.
		Check fuse holder is tight around fuse.

Pump

FAULT	PROBABLE CAUSE	CONTROL / REMEDY
Liquid leaks from the bottom of the pump.	Damaged diaphragm.	Replace diaphragm.
Grease leaks from the bottom of the pump.	Grease used has too low viscosity.	Change to recommended grease type.
Grease leaks from the shaft grease seals.	Grease used has too low viscosity.	Change to recommended grease type.
	Bearings worn/too high friction.	Replace pump bearings and grease seals.
Lack of pressure.	Pump valves are clogged or defect.	Check for obstructions or, if needed, replace valves.
	Clogged filters in fluid system.	Clean filters.
Vibrations in system and unpleasant noise from the pump.	Pump valves are clogged or defect.	Check for obstructions or, if needed, replace valves.
	Air is being sucked into system.	Check for leaks, pinholes in suction hoses, tightness / gaskets / O-rings of all fittings on the suction side.
Lack of flow / capacity.	Internal wear on conrod and conrod ring.	Poor greasing. Replace parts as needed and observe proper grease quality and intervals.
	Pump valves are clogged or defect.	Check for obstructions or, if needed, replace valves.
Extreme internal erosion on diaphragm covers and housing.	Too high vacuum caused by clogged suction filter or excessive pump speed (rpm).	Replace affected pump parts. Clean suction filter and observe maximum pump rpm.
	Lack of internal cleaning.	Use recommended cleaning procedures and add extra cleaning agents (e.g. AllClearExtra or similar).
	Lack of conservation of the fluid system during storage.	Always use a proper mixture of antifreeze during storage.
Short lifetime for diaphragm.	Overspeeding of the pump.	Observe maximum pump rpm.
	Too high vacuum when filling from external source:	
	Hose dimension is too small.	Fit a larger hose to the External Filling Device.
	Too long filling hose.	Park sprayer closer to the external tank and use a shorter hose.
	Bad filling conditions, e.g. too high water column when transferring water from a buried tank.	Change external water supply to obtain a lower water column.

Ace pump - Hydraulic Drive motor

Hydraulic seal failures are typically caused by high continuous pressure or pressure spikes in the return line. The motor seal is rated for 250 PSI (17.2 bar). Maintaining return line pressure below 100 PSI (6.9 bar) will extend motor seal life. Minimize back pressures in the return line by plumbing an unobstructed return back to the hydraulic reservoir or motor return port. Avoid returning the oil through remote valves, couplers, and long undersized hoses.



ATTENTION! Do not install any hydraulic components in series on the return line of the motor.

7 - Fault Finding

Hydraulic System, Z-version

FAULT	PROBABLE CAUSE	CONTROL/REMEDY
No boom movements when activated.	Insufficient hydraulic pressure.	Check oil pressure. Check tractor hydraulic oil level.
	Insufficient oil supply.	Oil flow must be 15 - 80 l/min (depending on the equipment on the sprayer). Check tractor hydraulic oil level.
	The operator has interrupted the boom folding by releasing the folding button in the tractor. Built-in timers automatically inhibit boom movements that may damage the machine.	Unfold the boom completely. Start folding again without letting go of the activated folding buttons for more than 10 seconds at a time, until the folding is completed.
	Blown fuse(s).	Check / replace fuse on tractor harness.
	Bad / corroded electrical connections.	Check / clean connections, multi plugs etc.
	Insufficient power supply.	Voltage on activated solenoid valve must be more than 8 volts. Use wires of at least 4 mm for power supply.
	Defective relay / diodes in junction box.	Check relays, diodes and soldering at PCB in junction box. LED diodes indicate boom functions.
	Clogged restrictors in bypass block.	Remove and clean restrictors in bypass block (See hydraulic diagram). Change hydraulic oil + filter.
	Wrong polarity.	Check polarity. Red positive (+), black negative (-).
ParaLift lock does not lock. Boom lift raises to max. position, when tractor hydraulics are engaged.	Back pressure in return line exceeds 15 bar.	Connect the return line with a free flow to hydraulic oil reservoir. Divide return line in two and lead return oil back to reservoir via two spool valves.
Oil heats up in Closed Centre systems.	Bypass valve does not close properly.	Check / close (screw in) by-pass valve.
	Internal leaks in flow regulator.	Replace flow regulator O-rings and backup rings. Replace flow regulator.
Individual hydraulic cylinder does not move.	Clogged restrictor.	Dismantle and clean restrictor.

Overview of Fuses

The fuses have a short text print nearby the socket, that refer to the function it protects. The schematic below shows an overview of fuses and functions. Be aware that the fuse size and location can vary, depending on the specific sprayer setup.



ATTENTION! The recommended fuses to be used, are Littelfuse ATOF® blade fuses rated 32 V, unless otherwise mentioned.

To verify the correct printed circuit board when inspecting a fuse, check the HARDI item number printed on the board.

Printed Circuit Board	PDU Board Item Number	Assigned Sprayer Function	Fuse Socket	Fuse Rating	Fuse Item Number	PCB Function	Connector
Power Distribution Unit PDU 2 Location: Front Sprayer: NAVIGATOR (i) DELTA FORCE	26070200	PulseSystem (PWM)	F1	5 A	261762	AUX 1	X1007
			F2			AUX 2	X1004
		Fluidbox	F3	5 A	261762	Guest (F3)	X400
		EExxx*	F4	25 A	261605	ECU-IO	X700
		EExxx*	F5	25 A	261605	ECU Master	X600
Power Distribution Unit PDU 3 Location: Front Sprayer: NAVIGATOR i DELTA FORCE All features	26070300		F1			AUX 1	X1004
			F2			AUX 2	X1007
			F3			Guest 1	X400
			F4			AUX SW 1	X1001
			F5			AUX SW 2	X1003
			F6			Guest 2	X500
		EExxx*	F7	25 A	261605	ECU-IO 1	X700
		EExxx*	F8	25 A	261605	ECU Master	X600
		EExxx*	F9	25 A	261605	ECU-IO 2	X800
Power Distribution Unit PDU 3 Location: Centre Section Sprayer: NAVIGATOR (i) DELTA FORCE	26070300	PrimeFlow	F1	10 A	28048500	AUX 1	X1004
		UC7**	F2	15 A	28048600	AUX 2	X1007
		UC7**	F3	10 A	28048500	Guest 1	X400
		BoomLight	F4	20 A	261340	AUX SW 1	X1001
			F5			AUX SW 2	X1003
			F6			Guest 2	X500
		EExxx*	F7	25 A	261605	ECU-IO 1	X700
		EExxx*	F8	25 A	261605	ECU Master	X600
		EExxx*	F9	25 A	261605	ECU-IO 2	X800

* either 26067700 SMARTCOM 6S15A, 26067800 SMARTCOM 6S31A or 26067900 SMARTCOM 14S19A

** with AutoTerrain/ActiveSlant UC7+

7 - Fault Finding

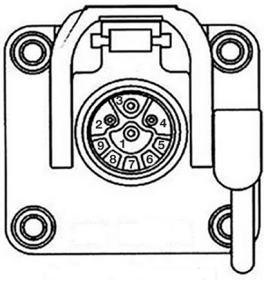
Other Fuse Types	HARDI Item Number	Fuse Socket	Fuse Rating	Fuse Item Number	Function on the Sprayer
ISOBUS retrofit kit for tractor	26040600	J03, J04	100 A Early type: MEGA Bolt-down fuse. Later type: MIDI Bolt-down fuse.	Early type: 26076800 Later type: 26076900	Cable between tractor battery and ISOBUS connection, red wire.
ISOBUS breakaway connector (IBBC) 	26040300	-	30 A JCASE cartridge fuse.	26076600	Pin 2 and 4: Medium power for ISOBUS guests.
		-	60 A JCASE cartridge fuse.	26076700	Pin 1 and 3: Main power for all electronics on sprayer.
PrimeFlow 24V/60W Power Supply PCB ASSY (optional)	26087700	F1	10A	28048500	24V Boom Power Left Side
		F2	10A	28048500	24V Boom Power Right Side



NOTE! When the tractor has ISOBUS as standard equipment, the fuse rating may depend on the tractor make.

VT Popup Messages - Boom

VT POPUP MESSAGE	REASONS FOR ACTIVATION
SYSTEM NOT CONFIGURED. A valid boom type must be selected in the MST.	No boom type has been selected in the MST. (CfgBoomType->BoomType)
Complete the folding of the 1st outer wing.	Inner fold button pressed when the 1st outer is not folded. 1st outer fold button must be held for the configured time (Cfg03Fold->Outer1FoldTime) before it is considered folded.
Lock the pendulum before folding the inner or 1st outer wings.	Inner fold or 1st outer fold buttons pressed while the pendulum is not locked.
Complete the folding of the 2nd outer wing.	1st outer fold button is pressed when 2nd outer is not folded. 2nd outer fold button must be held for the configured time (Cfg03Fold->Outer2FoldTime) before it is considered folded.
Unfold the inner wing before folding the outer wings.	1st outer fold or 2nd outer fold button pressed when inner RH boom has not been unfolded. Inner RH boom sensor is still reading folded or a sensor fault has occurred.
Centre the boom before folding or unfolding.	Any fold or unfold button pressed when the pendulum has not been centred (Cfg02Pendulum->SlantAngle). Pendulum not at the configured centre position, or the slant angle sensor has a fault.
Raise the boom before folding or unfolding the inner wing.	Inner fold or inner unfold button pressed when the boom is not above the configured paralift fold height (Cfg01Paralift->FoldEnableHeight). Paralift not at the configured fold height, or the height sensor has a fault.
Stop the vehicle before folding or unfolding.	Any fold or unfold button pressed when the vehicle speed is still above the zero-speed threshold (Cfg05Speed->SpeedZeroThreshold).
Pendulum lock failed!	Pendulum lock function times out after configured time (Cfg02Pendulum->LockTimeout) – expected lock feedback was not achieved. Potential issue with sensor feedback, cylinder position or hydraulic controls.
Pendulum lock state unknown!	Any function button pressed (apart from pendulum lock / unlock) when the pendulum state cannot be determined as locked or unlocked. The lock cylinder is not fully extended or retracted, or the feedback sensors have a fault.
Pendulum unlock failed!	Pendulum unlock function timed out when the vehicle was below the zero-speed threshold. (Cfg02Pendulum->UnlockTimeout) (Cfg05Speed->SpeedZeroThreshold) Potential issue with sensor feedback, cylinder position or hydraulic controls.
STOP! PENDULUM LOCKED!	Pendulum unlock function timed out when the vehicle was moving faster than the zero-speed threshold. (Cfg02Pendulum->UnlockTimeout) (Cfg05Speed->SpeedZeroThreshold) Potential issue with sensor feedback, cylinder position or hydraulic controls.
Centre the boom before locking the pendulum.	Pendulum lock button pressed while the boom is not centred.
Complete the unfolding of the 1st outer wing.	2nd outer unfold button is pressed when the 1st outer is not unfolded. 1st outer unfold button must be held for the configured time (Cfg03Fold->Outer1UnfoldTime) before it is considered folded.
Complete the unfolding of the inner wing.	1st outer or 2nd outer unfold buttons pressed when the inner RH boom is not fully unfolded. Inner RH boom sensor is still reading folded or a sensor fault has occurred.
Boom angle sensor fault.	Any fold or unfold button pressed when the boom angle sensor has a fault (voltage outside expected range 0.2...4.8V).
Boom height sensor fault.	Inner fold or unfold button pressed when the boom height sensor has a fault (voltage outside expected range 0.2...4.8V).
Inner RH boom fold sensor fault.	Any fold or unfold button pressed when the inner RH boom fold sensor has a fault (voltage outside high/low logic levels: 0.5...1.5V, 4.9...5.0V).
Pendulum lock sensor fault.	Any fold or unfold button pressed when the pendulum lock sensor has a fault (voltage outside high/low logic levels: 0.5...1.5V, 4.9...5.0V).
Pendulum unlock sensor fault.	Any fold or unfold button pressed when the pendulum unlock sensor has a fault (voltage outside high/low logic levels: 0.5...1.5V, 4.9...5.0V).
Auto-centre failed due to timeout.	Auto-centre process stopped due to the boom angle feedback not reaching the centre position within the configured time (Cfg02Pendulum -> AutoCentreTimeout).
Unfold the inner wing before unlocking the pendulum.	Pre-condition: FTZ boom selected and pendulum lock option has been enabled. Pendulum unlock button pressed while the inner wing is still folded.

7 - Fault Finding

Mechanical Problems

Emergency Operation - Liquid System

In case of a power failure, it is possible to operate all functions of the operating unit manually.

Disconnect the power supply to the sprayer.

Manually turn the control knobs on the distribution valves.

- If easily turned by hand, the power did shut off correctly.
- If they are hard to turn, you need to disconnect e.g. ISOBUS cable to turn off the power for these valves.

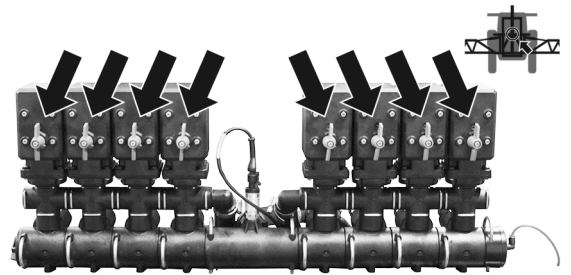

NOTE! The handle on the distribution valve has a peg that acts as a mechanical stop.

Emergency Operation - Hydraulics

In case of power failure, operate the damper control as follows:

1. Remove plastic cover (A) from valve (B).
2. Turn valve (B) inwards.

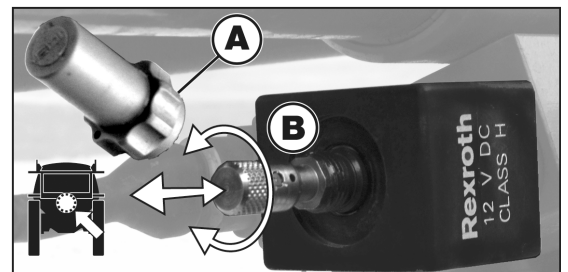

Emergency Operation - EasyCleanFilter

If difficulties occurs with opening the filter and closing the built-in valve, follow this emergency operation:

1. Drain the filter before the filter element possible at the drain plug (B).
2. Emergency handle the filter by using a 13 mm wrench on the key profile (A) located at the bottom of the filter housing.



WARNING! Always wear protective clothing and gloves before opening the filter!

Hydraulic Diagrams

Hydraulics for Boom of 24 Meters (Z-version)

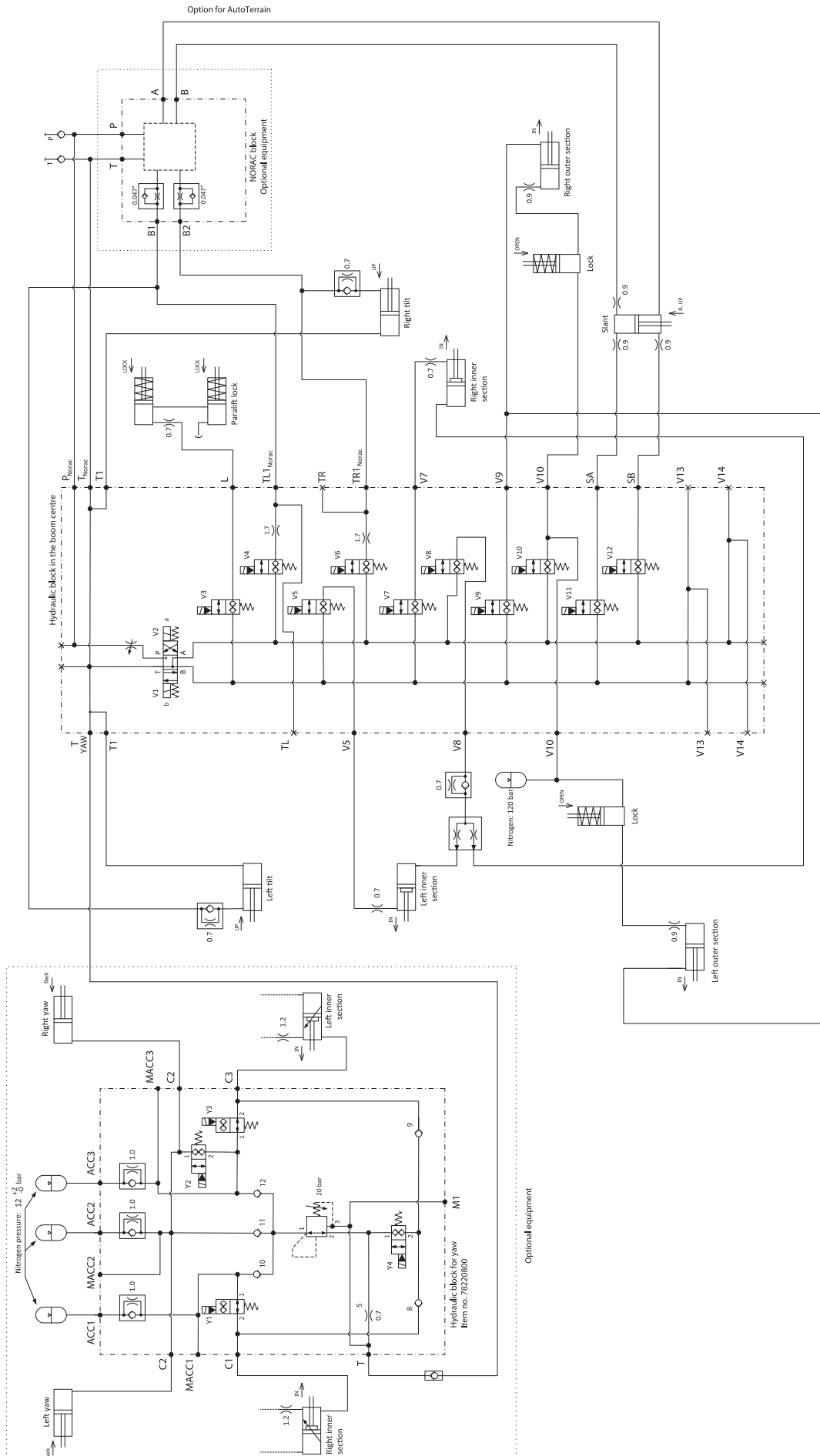

8 - Diagrams

Hydraulics for Boom of 24-30 Meters (Z-version)

With Individual Fold

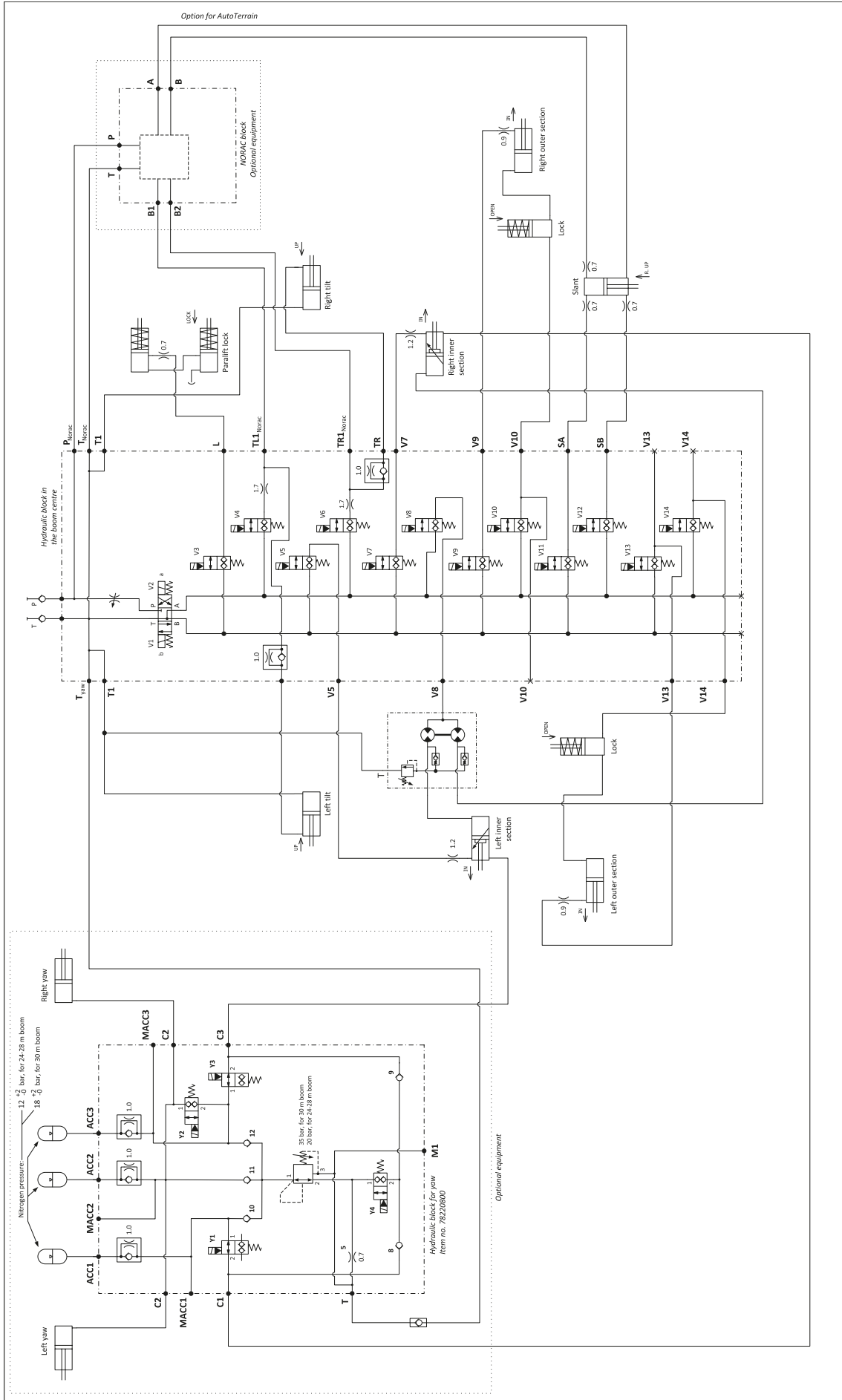

Hydraulics for Boom of 27-30 Meters (Z-version)

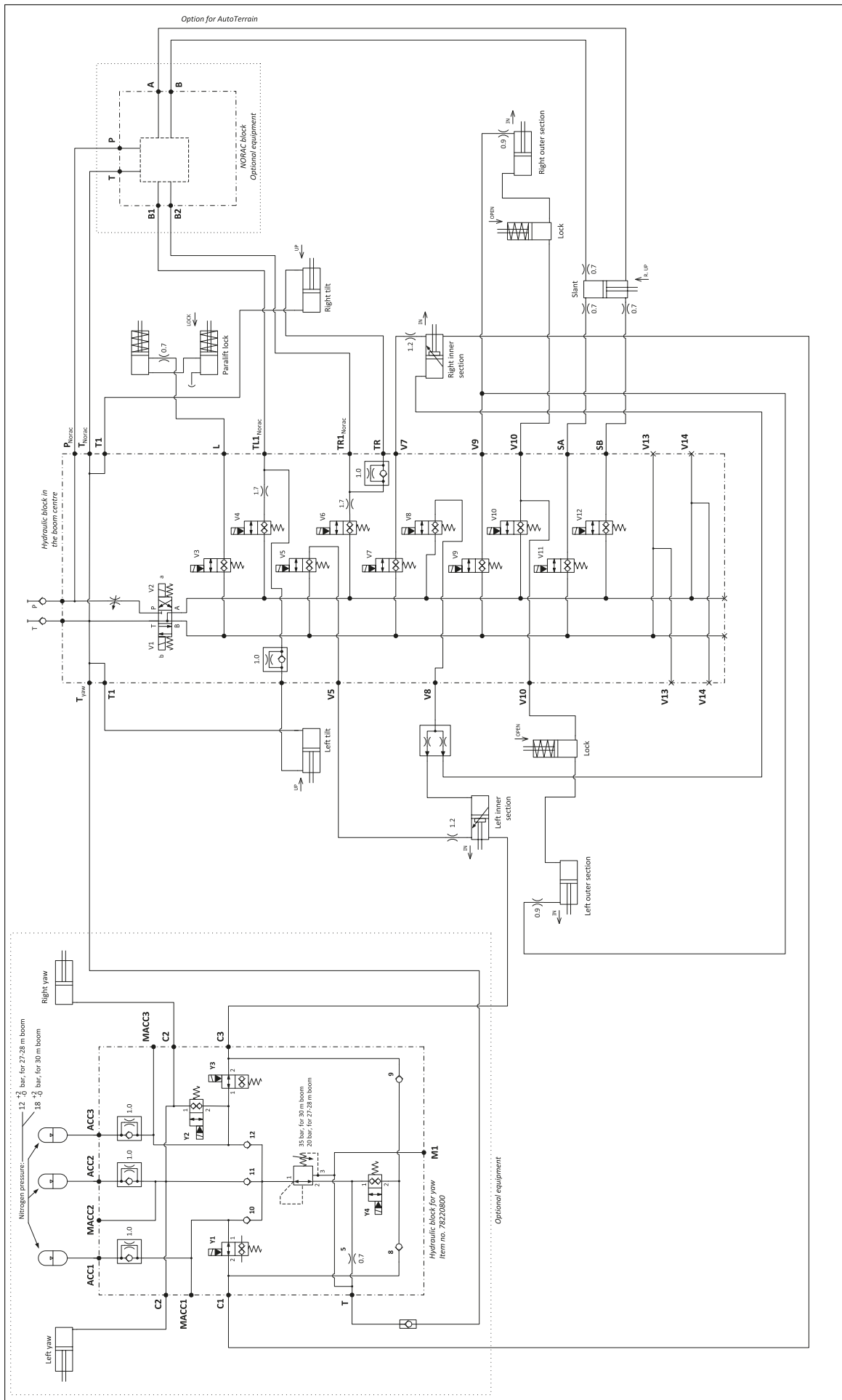

8 - Diagrams

Hydraulics for Boom of 36 Meters (Z-version)

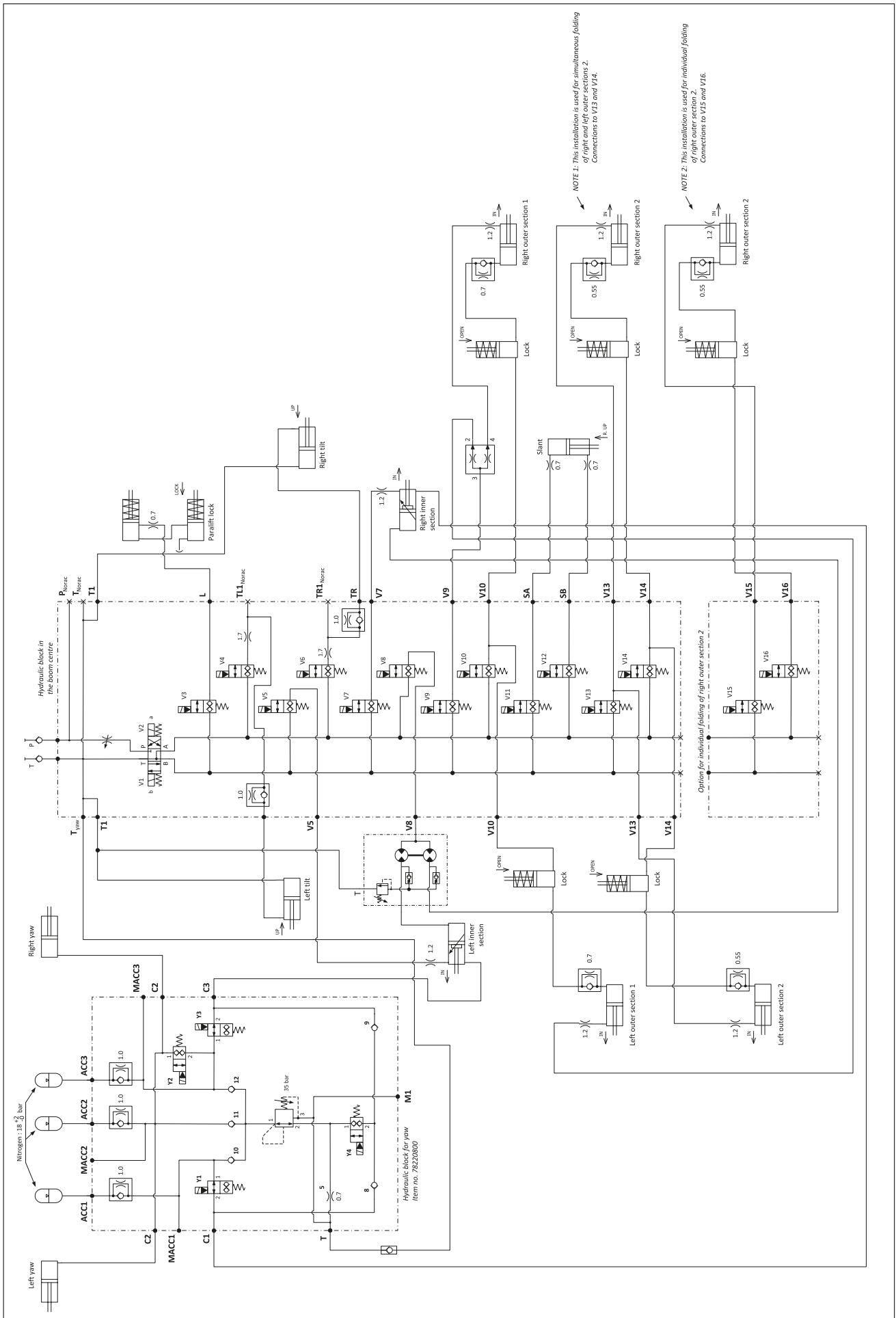

Hydraulics for Boom of 36 Meters (Z-version)

Including NORAC control system for spray height.

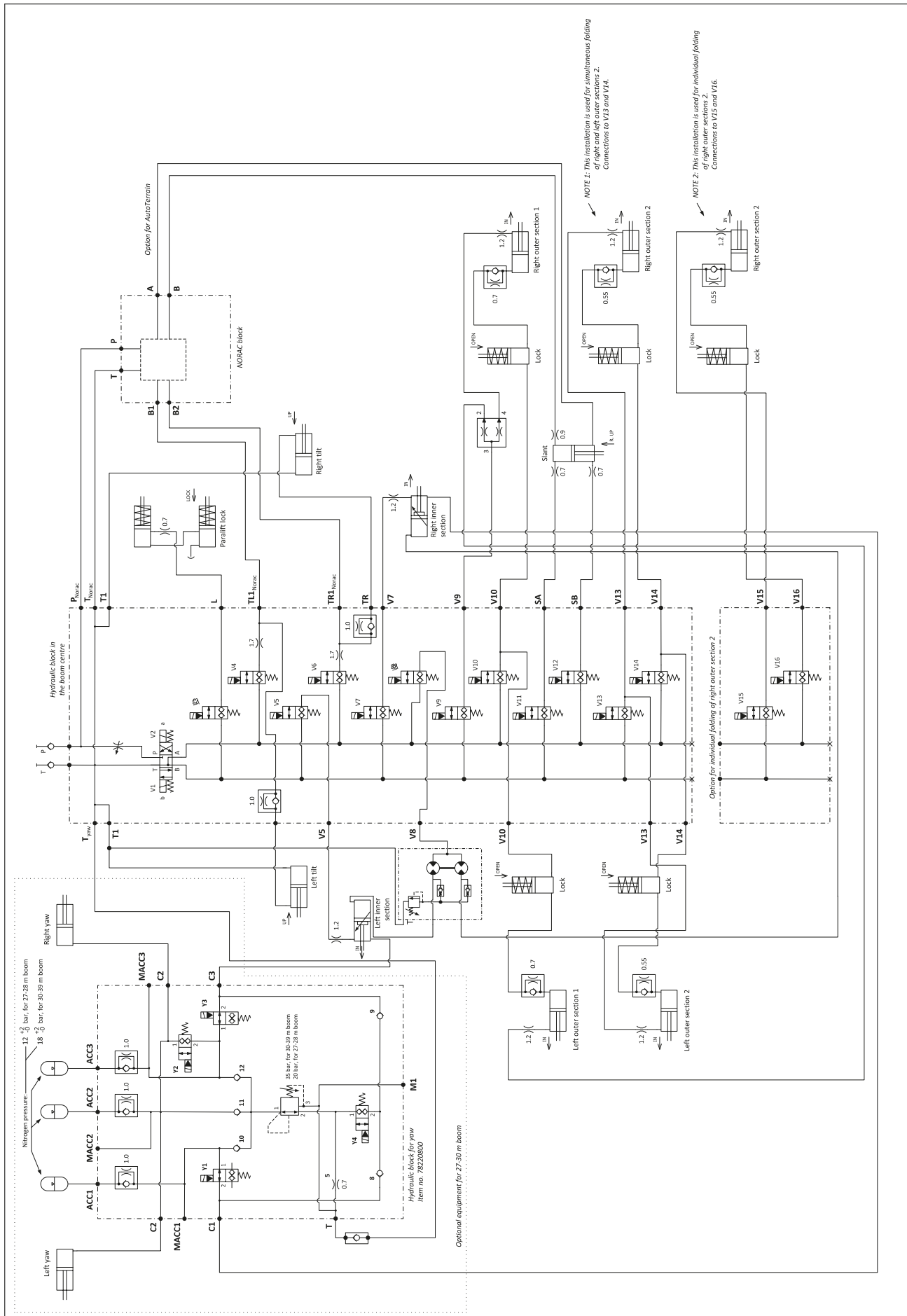

8 - Diagrams

Liquid System

Diagram - Basic Liquid System

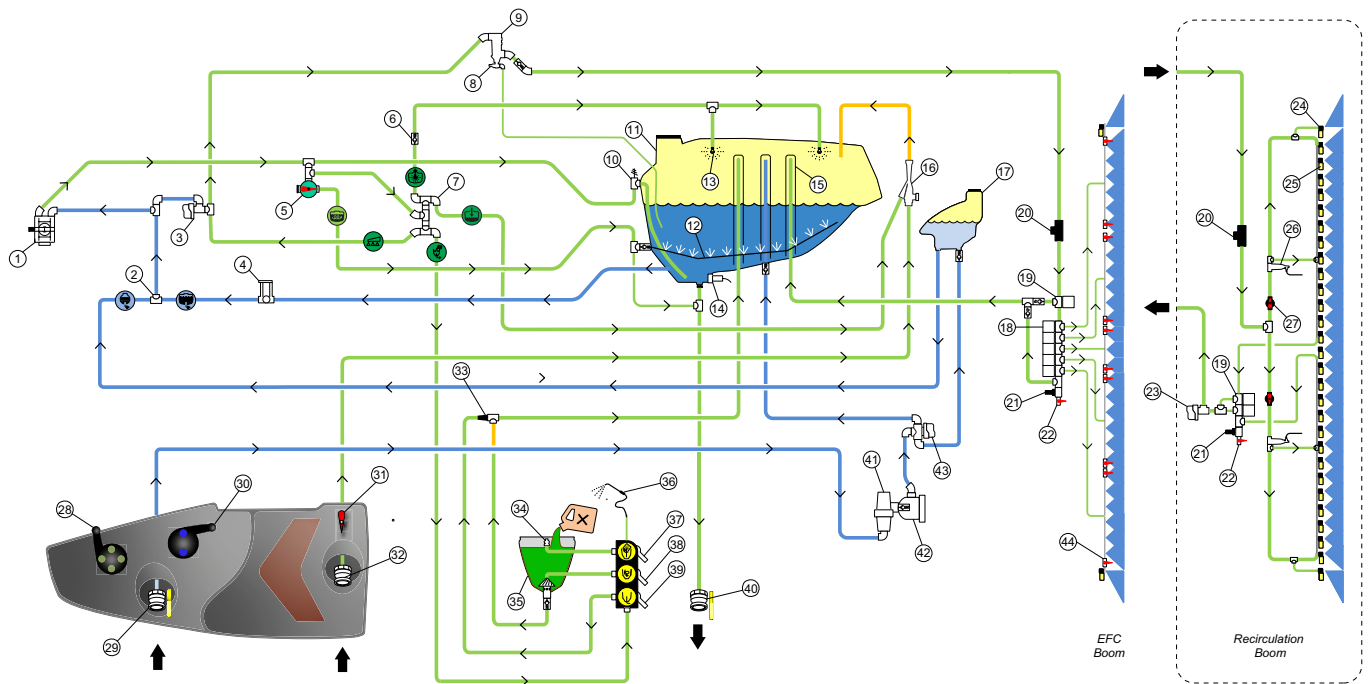

- | | |
|--------------------------------|-----------------------------------|
| 1. Main Pump | 23. Bypass Flow Restriction Valve |
| 2. Suction SmartValve | 24. End Nozzle |
| 3. Pressure Regulation Valve | 25. Spray Nozzle |
| 4. EasyCleanSuction Filter | 26. Boom Filter |
| 5. Agitation Valve | 27. Boom Shut-off Tap |
| 6. Check Valve | 28. Pressure Valve Selector |
| 7. Pressure SmartValve | 29. Filling Coupler |
| 8. Filter Boost Clean Valve | 30. Suction Valve Selector |
| 9. Cyclone Pressure Filter | 31. Venturi Shut-off Valve |
| 10. Pressure Relief Valve | 32. Venturi Fast-fill Coupler |
| 11. Main Tank | 33. Ejector for Turbofiller |
| 12. Agitation Pipe | 34. TurboFiller Rinse Nozzle |
| 13. Tank Rinsing Nozzles | 35. TurboFiller |
| 14. Tank Gauge Pressure Sensor | 36. Hand Gun |
| 15. Tank Riser Tubes | 37. TurboFiller Rinse Selector |
| 16. Venturi | 38. TurboFiller Fill Selector |
| 17. Rinse Tank | 39. TurboFiller Suction Selector |
| 18. Section Valves | 40. Dump Coupler |
| 19. Bypass Valve | 41. Clean Fill Filter |
| 20. Flow Meter | 42. Banjo Pump (optional) |
| 21. Boom Pressure Sensor | 43. Filling Direction valve |
| 22. Manifold Cleaning Tap | 44. Boom Flush Taps (optional) |

Other Specifications

Tightening Bolts and Nuts

When tightening bolts and nuts as a part of periodic service or due to replacement of spare parts, it is important to apply the correct torque. This will prevent accidents and prolong the lifetime of the parts included in the bolted joints.

If not stated otherwise in this book, please tighten bolts and nuts using the following torques.

Material: Surface Treated Steel		
Bolt Size (metric)	Recommended Torque (Nm)	Maximum Torque (Nm)*
M4	2.4	3
M5	5	6
M6	8	10
M8	20	25
M10	39	50
M12	70	85
M14	112	140
M16	180	215
M18	240	305
M20	350	435
M22	490	590
M24	600	750
M27	976	1100
M30	1300	1495

Material: Stainless Steel		
Bolt Size (metric)	Recommended Torque (Nm)	Maximum Torque (Nm)*
M4	1.7	2.1
M5	3.5	4.2
M6	5.6	7.0
M8	14	17.5
M10	27	35
M12	49	60
M14	78	98
M16	126	151
M18	168	214
M20	245	305
M22	343	413
M24	420	525
M27	683	770
M30	910	1047

*Exceeding this value results in a great risk of deforming the bolt.



WARNING! Applying too little torque will result in these risks:

- Bolted joints will rattle and thus fail under fatigue.
- Bolts worn out quickly and thus will not fulfil their design purpose.
- Bolted joints will come loose.
- Accidents caused by assembled parts coming apart due to bolts or nuts failing or falling off.



WARNING! Exceeding the maximum torque will result in these risks:

- Damaging or stripping the threads and deforming the bolt.
- Bolt heads will be broken.
- Bolted joints will come loose.
- Accidents caused by assembled parts coming apart due to bolts breaking.

8 - Diagrams

Tightening Hydraulic Hoses

When tightening hydraulic hoses as a part of periodic service or due to replacement of spare parts, it is important to apply the correct torque. This will prevent accidents and prolong the lifetime of the parts connected with the hoses.

If not stated otherwise in this book, please tighten hydraulic hoses using the following torques:

Hose Size	Thread Size	Spanner Size	Recommended Torque
1/4"	9/16"	19 mm	25 Nm
3/8"	11/16"	22 mm	38 Nm
1/2"	13/16"	24 mm	57 Nm
3/4"	1.3/16"	36 mm	130 Nm
1"	1.7/16"	41 mm	170 Nm

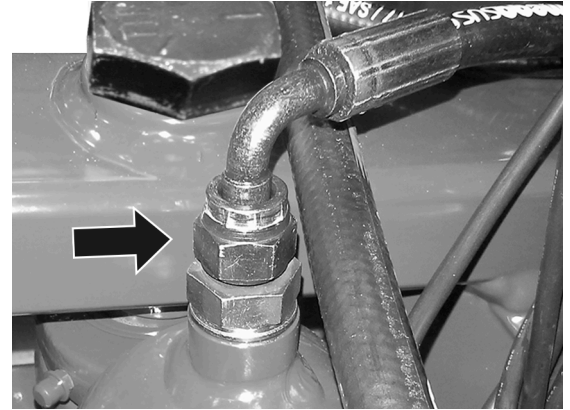

DANGER! A hydraulic hose or joint leaking or coming apart with the oil under pressure can cause severe injuries to persons standing nearby! The oil can be very hot, around 80 °C, and the oil streaming out can penetrate human skin. Risk of burns on the skin, internal injuries and facial injuries.



WARNING! Applying too little torque will result in these risks:

- Hydraulic joints will leak due to the high oil pressure.
- Hydraulic joints will rattle and thus fail under fatigue.
- Hydraulic joints worn out quickly and thus will not fulfil their design purpose.
- Accidents caused by sudden loss of oil pressure due to hydraulic parts coming apart.



WARNING! Applying too much torque will result in these risks:

- Damaging or stripping the threads and deforming the hydraulic joints.
- Fittings will be broken.
- Hydraulic joints will leak.
- Accidents caused by assembled parts coming apart due to bolts breaking.



WARNING! Often a hydraulic joint turned when assembling to make it fit between other components on the sprayer. Remember to finish off by applying the correct torque.



NOTE! The sealing system for hoses and fittings is ORFS type (O-Ring Face Seal). This ensures a high level of sealing and good vibration resistance. The fittings use the O-ring compression mechanism to seal.

Tyre Pressure

Tyre pressure depends on:

- Actual axle load.
- Tyre size.
- Actual speed of the sprayer.

This means that it is often not possible to drive a fully loaded sprayer at maximum speed, when having narrow wheels mounted.

 NOTE! Some tyre sizes listed may not be available for your sprayer.

Tyre Size	Load Index	Tyre Pressure (bar)	Speed:	Speed:	Speed:
			In Field	25 km/h	40 km/h
			Max. Axle Load (kg)	Max. Axle Load (kg)	Max. Axle Load (kg)
270/95 R48	142D/151A8	4.3	7320	7536	6960
300/95 R46	148D/151A8	4.3	8688	8952	8280
340/85 R48	151 D/154A8	5.2	10488	10800	9984
380/90 R46	173 D	5.2	16704	15600	15600
380/90 R50	175 D	5.2	18216	16891	16560
420/85 R38	144 D/144A8	1.9	N/A	N/A	6720
420/80 R46	159 D/162A8	3.8	16104	12432	11496
460/85 R38	149 D/149A8	1.9	N/A	N/A	7800
480/80 R46	158 D	6.1	N/A	18912	17040
520/85 R38	155 D/155A8	1.9	N/A	N/A	9300
520/85 R42	157 D/157A8	1.9	N/A	N/A	9900
520/85 R46	170 D	1.9	15432	14400	14400
580/85 R42	183 D	3.6	22512	21000	21000
650/65 R42	158 D/161A8	1.9	11736	12096	11160

N/A: Data is not available from tyre supplier.



WARNING! Never inflate tyres to more than the pressure specified in the table. Over-inflated tyres can explode causing severe injuries! Always check the information about pressure on the tyre itself.



WARNING! If changing tyres, always use tyres with minimum load index as specified in the table.



ATTENTION! Legislation and requirements regarding maximum allowable axle load, when driving on public roads, may vary from country to country. Always follow local legislation in force at any time.



NOTE! The axle load is two times the tyre load for the sprayer. Be aware of the specific data for your sprayer, as some tyres in the list above are not applicable.



NOTE! Refer to "Tyre Change" on page 167 for tyre fitting instructions.



ATTENTION! The tyres on your sprayer are approved for max. 40 km/h and the lifetime will decrease at hire speed.

8 - Diagrams

Electrical Connections

Rear Lights

The wiring is in accordance with ISO 1724.

Position	Designation	Wire Colour
1	Left direction indicator	Yellow
2	Free (max. 55 W)	Blue
3	Ground	White
4	Right direction indicator	Green
5	Right rear position lamp	Brown
6	Stop lamps	Red
7	Left rear position lamp	Black

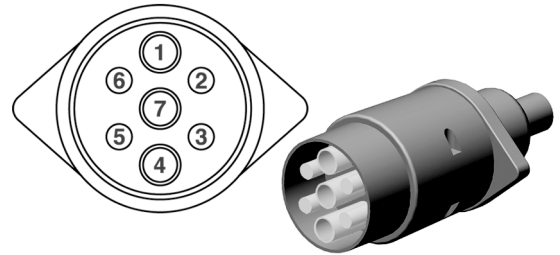

Boom and Work Light

The Boom and work lights connects to the SmartCom box with a dedicated wiring loom.

The specific wiring diagrams are possible to obtain separately, as the configuration and number of lights may differ between sprayer variants.

Contact the HARDI dealer if necessary.

- 10 Hours Service
 - Brakes, 142
 - Cyclone Filter, 138
 - EasyCleanFilter, 137
 - In-Line Filter, 142
 - Nozzle Filters, 142
 - Spraying Circuit, 142
- 100 Hours Service
 - Air Filter/Lubricator, 148
- 1000 Hours Service
 - Wheel Bearings and Brakes, 160
- 250 Hours Service
 - Parking Brake, 153
 - Wheel Bearings, 153
- 50 Hours Service
 - Greasing the Pump, 160
 - PTO, 146
 - Transmission Shaft, 160
 - Tyre Pressure, 147
- A**
- Agitation, 116
 - Before Resuming a Spray Job, 117
 - Manual Valve, 55, 103
- Air Activated Brakes
 - Dual-Line, 91
 - Single-Line, 92
- Air Filter
 - 100 Hours Service, 148
- B**
- Boom
 - Pipe clamp, 168
 - Pipe Snap-Lock, 167
 - Re-tightening, 149
 - Venting Hydraulics, 174
- Boom Width
 - Single-side Half Width, 98
- BoomPrime, 203
- Brakes, 157
 - Dimensions, 134
- C**
- Chemical Container Cleaning
 - Lever, 109
- Cleaning, 37, 118
 - Chemical Container, 111, 112, 114
 - Environmental Precautions, 36
 - Environmental Protection, 24
 - RinseTank and Rinsing Nozzles, 123
 - Sprayer Outside, 124
 - Standard, 120
- CleanWaterTank, 59
- Clogging Indicator, 57
- ComfortTrack
 - SetBox Controls, 68
- Control Unit, 116
- CycloneFilter, 56, 91
 - 10 Hours Service, 138
- D**
- Diagram
 - Liquid System with Options, 203
- Diaphragm Renewal, 162
- Dilution
 - In-field, 123
- Disposal, 24
- Drain Valve, 125
- Drawbar
 - Coupling Type, 69

Index

Driving Speed

- Adjusting the Sensor, 89
- Ring, 89
- Transducer, 89

DynamicFluid4, 53

- Location of Sensors, 53

E

EasyCleanFilter, 56, 57

- 10 Hours Service, 137

EcoFill, 118

Electrical

- ISOBUS Connector, 64
- System, 33
- Traffic Light Connector, 64

Emergency Operation

- Hydraulics, 196

Environmental

- Precautions, 36
- Protection, 24

External Filling Device, 105

F

Fault codes - HC 6500, 195

Filling

- CleanWaterTank, 108
- Liquid Chemicals in TurboFiller, 112
- RinseTank, 107
- Washing Location, 101

Filter Element of the Air Filter, 156

Fluid Regulation, 53

Fuses overview, 193

G

Grease

- Gun Calibration, 132
- Nipple, 132

Grip, 68

- Controls, 116

Grip controls, 71

H

Hose

- Package Support, 79
- Tightening, 204

Hydraulic

- Systems, 203

Hydraulic Motor

- Adjustment of Oil Flow, 82

Hydraulic System, 80

Hydraulics

- Boom Folding, 85
- Closed Centre, 66
- Open Centre, 66
- ParaLift, 65
- System, 32
- Venting Cylinders, 174

Hydraulics for Boom, 200, 201

I

In-Line Filter, 56, 139

IntelliTrack, 68, 116, 187

J

Jack up the Sprayer, 74

L

Level Indicator, 165

Liability, 10

Light

- Night Spraying, 99
- Rear, 206

Light Bulbs, 172

Liquid System

- Faults, 190

Load Apportioning Valve, 134

Load Sensing, 84

Lubrication, 131

- Boom Centre, 132
- Grease Nipple, 132
- Gun Calibration, 132

N

Night Spraying Light, 99, 128

Nozzle

- Filters, 136
- Holder, 168
- Leaks, 168
- Pressure Gauge, 69

Nozzle Pipe

- Assembly, 170
- Gasket Types, 170
- Lock ring, 170
- O-ring, 168, 169, 170
- Remove Lock Ring, 170
- Union Nut, 170

O

Obligations, 9

- Operator, 11

Occasional Maintenance, 159

Off-Season Storage, 187

Operational Problems, 189

- General, 100

Operator

- Intended Place, 25
- Limitations, 23
- Safety, 78
- Training, 19

P

ParaLift, 65

- Wear Bushing Replacement, 171

Parking Brake, 153

Parking the Sprayer, 112

Pendulum Damping, 87

Personal Protection, 108

Pneumatic Brakes

- Dual Line Brakes, 91

Power

- Night Spraying Light, 99

Power Supply, 64

- Pressure Filter, 58
- PTO, 34
 - 50 Hours Service, 160
 - Installation, 78
 - Replacement of Cross Journals, 172
 - Replacement of Shield, 172
 - Universal Joint Shaft, 34
- Pump, 50
 - Lifting, 160
 - Speed Transducer, 161
- Q**
- Quick Reference
 - Cleaning, 119
- R**
- Rear Lights, 206
- Renewal
 - Diaphragms, 162
 - Pump Valves, 164
 - Wear Bushing on ParaLift, 171, 186
- Requirements
 - Filling/Washing Location, 101
 - Tractor, 76
- Residual Energy, 21
- Rinsing
 - MainTank Not Empty, 124
 - RinseTank, 59
 - Rinsing Nozzles, 123
- Road
 - Checking the Vehicle, 30
 - Safety Kit, 88
 - Transport, 30
- Rubber Dampers, 172
- S**
- Safety
 - Accident Prevention, 27
 - Authorized Persons, 19
 - If Information is Ignored, 26
 - Informal Measures, 18
 - Locker, 70
 - Normal Operation, 20
 - Operator, 78
 - Personal Protective Equipment, 13
 - Precautions, 108
 - Protection Equipment, 17
- Sensors
 - Speed, 89
- Service and Maintenance, 38
 - Work, 22
 - Work Precautions, 37
- Service Intervals, 135
- SetBox Controls, 116
- SmartValve, 54, 102
- Snap-Lock For Feed Pipes, 167
- Spare Parts
 - Wear Parts and Aids, 23
- Specifications
 - Brakes, 134
- Speed
 - Pump, 161
 - Sensor for Sprayer, 89
- Spray Technique, 128
- Sprayer
 - Coupling and Uncoupling, 28
 - Field Operation, 36
 - Parking, 117
 - Risks in Handling, 12
 - Use, 29, 50
 - Working Area, 35
- Sprayer Use, 96, 164
- Spraying Circuit, 142
 - standard, 138
- Steering Hydraulics, Venting, 175, 186
- Suction
 - Filter, 57
 - Valve, 54, 102
- T**
- Tightening
 - Hydraulic Hoses, 160
 - Torque, 160
- Transmission Shaft, 78
- Transport Lock, 92
- TurboFiller, 52, 109, 118
 - Rinsing, 114
 - Suction Valve, 109
 - TurboDeflector Valve, 53
- Turning the Wheel Rim, 91
- Tyre
 - 50 Hours Service, 147
 - Change, 172, 186
 - Liquid-Filled, 93
 - Load Index, 205
- V**
- Valve
 - Open Centre Hydraulics, 84
 - Pressure Regulation, 53
 - Renewal on Pump, 162
 - TurboDeflector, 109
 - TurboFiller Suction, 109
- Valves
 - Symbols, 56, 102
- View, 43, 44, 50, 159
- VT, 195
- W**
- Water
 - Filling, 104
- Wheel
 - Bearings, 153, 157
 - Nuts, 147
 - Rim, 91

Spare Parts Information

To see updated spare part information, visit the Agroparts website on the internet.

Here all parts information can be accessed in the spare parts catalogue:

1. Go to www.agroparts.com, register for free and log in.
2. Select "HARDI" in the menu on the left.
3. Select "Spare parts catalogue" and find your spare part.
4. Online ordering is also possible.
5. Contact your HARDI dealer for further information on spare parts.



User Evaluation

Dear Reader,

We update our instruction books regularly. Your suggestions for improvement are appreciated and will help us to create ever more user-friendly instructions. Send us your suggestions to this e-mail address:

TechDoc@hardi.com

Thank you.

HARDI AUSTRALIA PTY LTD

534/538 Cross Keys Rd, Cavan SA 5094 - AUSTRALIA

